

Name: _____ Index No. _____

2601/104

2602/104

2603/104

ENGINEERING DRAWING, MATERIALS,
PROCESSES AND WORKSHOP TECHNOLOGY

Oct./Nov. 2015

Time: 3 hours

Candidate's Signature: _____

Date: _____



THE KENYA NATIONAL EXAMINATIONS COUNCIL

**DIPLOMA IN ELECTRICAL AND ELECTRONICS ENGINEERING
(POWER OPTION)
(TELECOMMUNICATION OPTION)
(INSTRUMENTATION OPTION)
MODULE I**

ENGINEERING DRAWING, MATERIALS, PROCESSES AND WORKSHOP TECHNOLOGY
3 hours

INSTRUCTIONS TO CANDIDATES

Write your name and index number in the spaces provided above.

Sign and write the date of the examination in the spaces provided above.

You should have the following for this examination:

Drawing instruments;

Mathematical tables/ Scientific calculator;

Drawing paper A3.

This paper consists of EIGHT questions in TWO sections; A and B.

Answer THREE questions from section A in the spaces provided in this paper and TWO questions from section B on the drawing paper.

Maximum marks for each part of a question are as indicated.

Do NOT remove any pages from this booklet.

Candidates should answer the questions in English.

For Examiner's Use Only

Section	Question	Maximum Score	Candidate's Score
A		20	
		20	
		20	
B		20	
		20	
TOTAL SCORE		100	

This paper consists of 16 printed pages

Candidates should check the question paper to ascertain that all the pages are printed as indicated and that no questions are missing.

SECTION A: MATERIALS, PROCESSES AND WORKSHOP TECHNOLOGY

D.N 2015

Answer any **THREE** questions from this section.

1. (a) State **three** protective measures to be observed with regard to workshop clothing when using electrical machines. (3 marks)
- (b) (i) Explain **four** classes of fire.
(ii) State the type of fire extinguisher for each class of fire in b(i). (8 marks)
- (c) Explain how the following factors contribute to accidents in the workshop:
(i) human;
(ii) environment. (4 marks)
- (d) Outline the procedure for administering mouth to mouth resuscitation to an unconscious electric shock victim. (5 marks)
2. (a) Explain the following properties of engineering materials:
(i) ductility;
(ii) conductivity. (4 marks)
- (b) Describe the following finishing and decorative processes for engineering materials:
(i) electroplating;
(ii) enamelling. (4 marks)
- (c) Outline the procedure for bending a metal rod in forging. (4 marks)
- (d) Draw a labelled diagram of an anvil used in forging. (8 marks)
3. (a) (i) State **two** applications of mechanical fasteners.
(ii) Explain **four** differences between soldering and brazing. (6 marks)
- (b) Draw part of a vernier scale to show a reading of 25.44 mm. (5 marks)

- (c) (i) Draw a labelled diagram of a flat file.
 (ii) State **four** ways of taking care of files.

(9 marks)

4. (a) (i) List **two** types of materials used in sheet metal work.
 (ii) Explain the procedure for fabricating an open box using a tinplate.

(10 marks)

- (b) Figure 1 shows a diagram of a bench drilling machine. Name the parts labelled A to H.
 (8 marks)

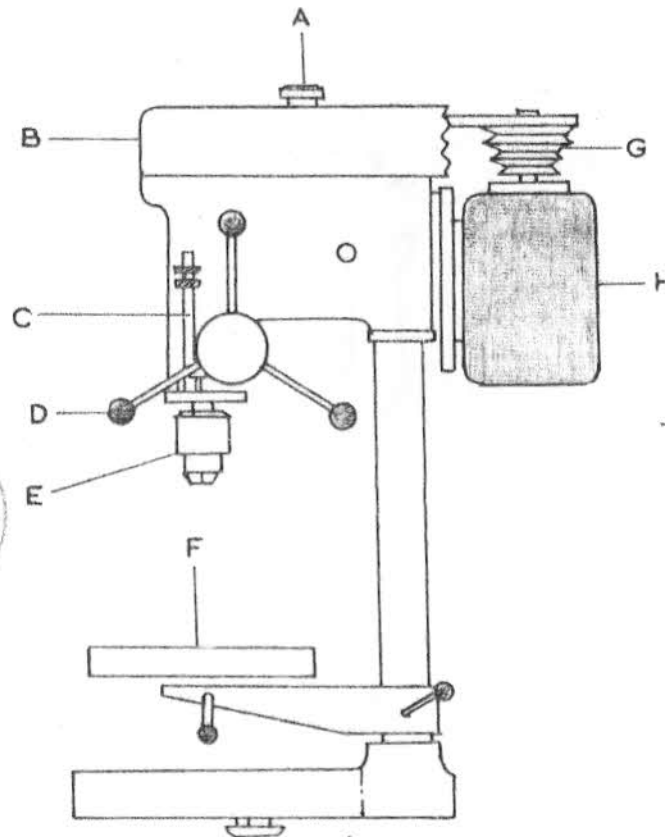

Fig. 1: Bench Drilling Machine

- (c) Sketch the following lathe tool shapes:

- (i) round nose roughing tool;
 (ii) parting-off tool.

(2 marks)

SECTION B: ENGINEERING DRAWING

Answer any *TWO* questions from this section.

5. Figure 2 shows an isometric drawing of an anchor stop. Draw, in third angle projection, the following views:

- (a) a plan;
- (b) an end elevation;
- (c) a front elevation in the direction of arrow A.

Insert **six** major dimensions.

(20 marks)

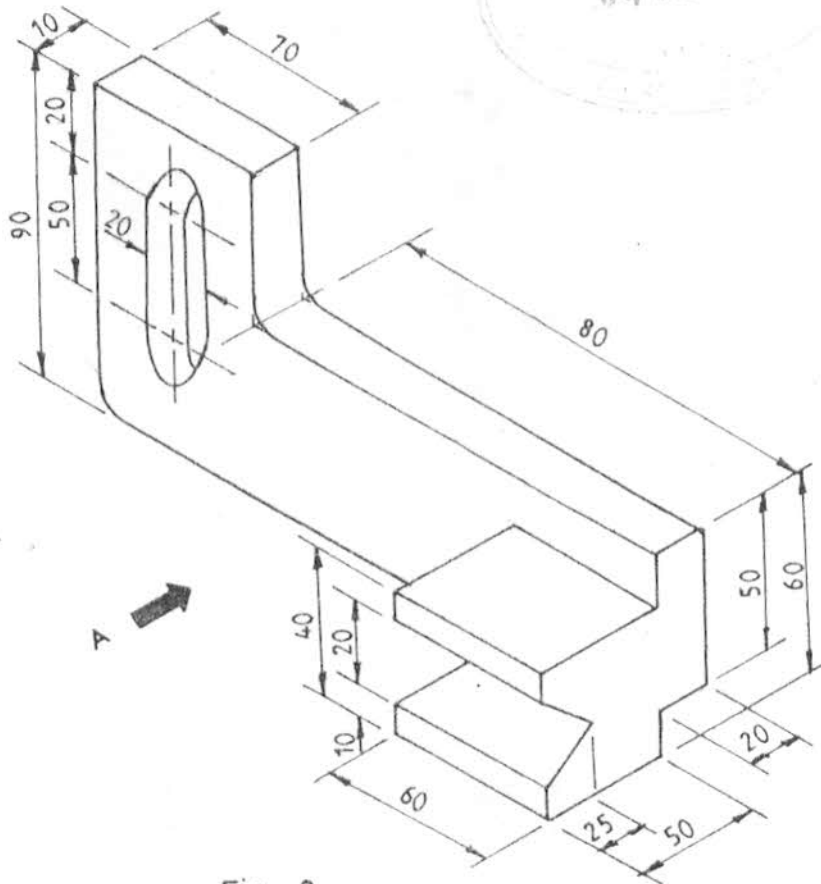

Fig. 2

6. (a) Draw free hand sketches of the following hand tools:

- (i) long nose pliers;
- (ii) side cutter pliers;
- (iii) bent end scriber;
- (iv) combination pliers;
- (v) dot-punch.

(10 marks)

2601/104

2602/104

2603/104

Oct./Nov. 2015

- (b) Figure 3 shows two views of an object. Draw an oblique cabinet pictorial view taking corner N as the lowest point. (10 marks)

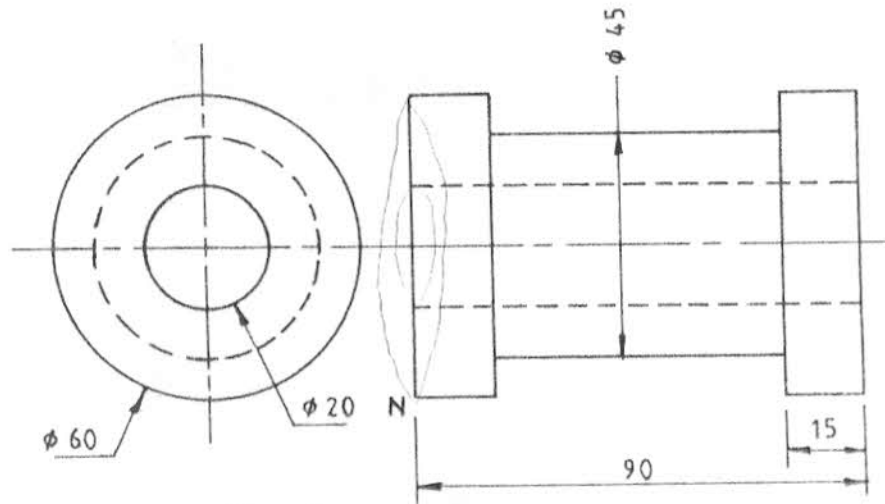

Fig. 3



2601/104
2602/104
2603/104

Oct/Nov. 2015

74 55 44 0204

7. Figure 4 shows an elevation of a truncated cylinder. Redraw full size the elevation and complete the following:

- plan;
- true shape;
- end elevation;
- surface development.

(20 marks)

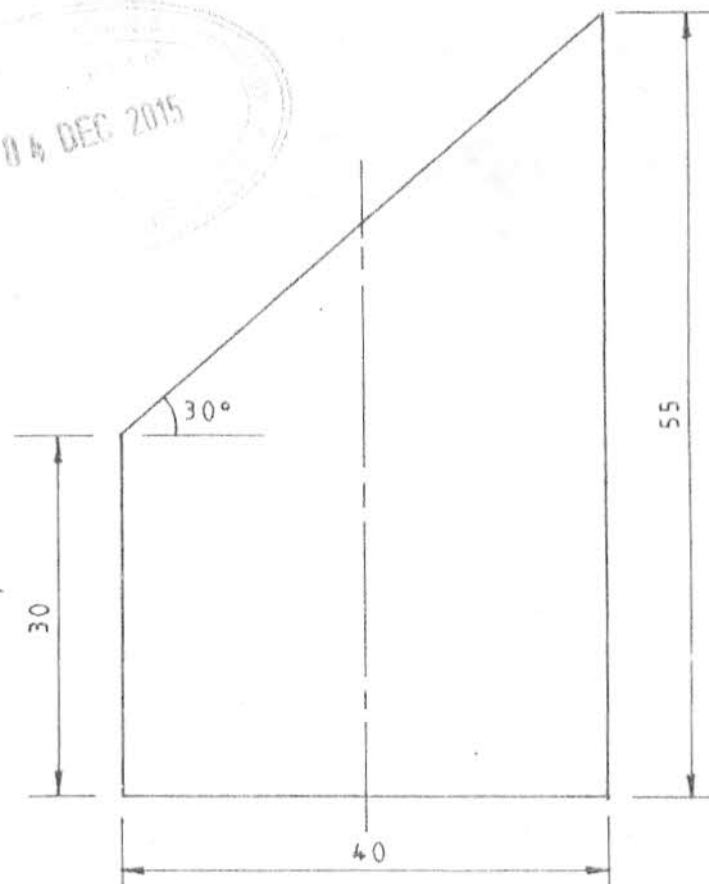

Fig. 4

- Use the rectangular method to draw an ellipse with major and minor axes as 130 mm and 100 mm respectively. (15 marks)
 - Using a pair of compasses and a ruler only, construct a regular pentagon with sides 40 mm. (5 marks)