

2920/202B

COMPUTER APPLICATIONS II

July 2016

Time: 1 hour



THE KENYA NATIONAL EXAMINATIONS COUNCIL

DIPLOMA IN INFORMATION COMMUNICATION TECHNOLOGY

MODULE II

COMPUTER APPLICATIONS II

Practical

1 hour

INSTRUCTIONS TO CANDIDATES.

You have **ten** minutes to read through the instructions and questions before starting the examination.

Any problem with the computer should be reported to the invigilator immediately.

Direct any question(s) to the invigilator only. Conversing with fellow students may lead to disqualification.

Write your **name** and **index number** on answer booklet and the rewritable **CD** provided.

Type **your name** as a header on each sheet of paper used.

This paper consists of **TWO** tasks. Perform the **TWO** tasks.

Each task carries **20** marks.

Read the instructions of each task carefully.

Print on **one** side of the paper(s) only and use a fresh sheet of paper for each task.

Hand over your **printout** and the **Rewritable CD** to the invigilator at the end of the examination.

This paper consists of 5 printed pages.

Candidates should check the question paper to ascertain that all the pages are printed as indicated and that no questions are missing

© 2016 The Kenya National Examinations Council

Turn over

GENERAL INSTRUCTIONS TO CANDIDATES

1. Create a folder named **KNECEXAM** on the desktop in which to save all your work.
2. Ensure that the **KNECEXAM** folder and all its content is burnt onto the Rewritable CD provided at the end of the examination.

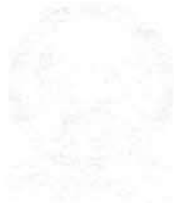

TASK 1

- (a) Open a CAD program and make the following drawing settings:
- (i) Units: millimetres.; (½ mark)
 - (ii) Precision: 1 decimal place. (½ mark)
 - (iii) Model space: 3D Modelling (½ mark)
- (b) (i) Draw the 3D drawing as it appears in figure 1. (9 marks)

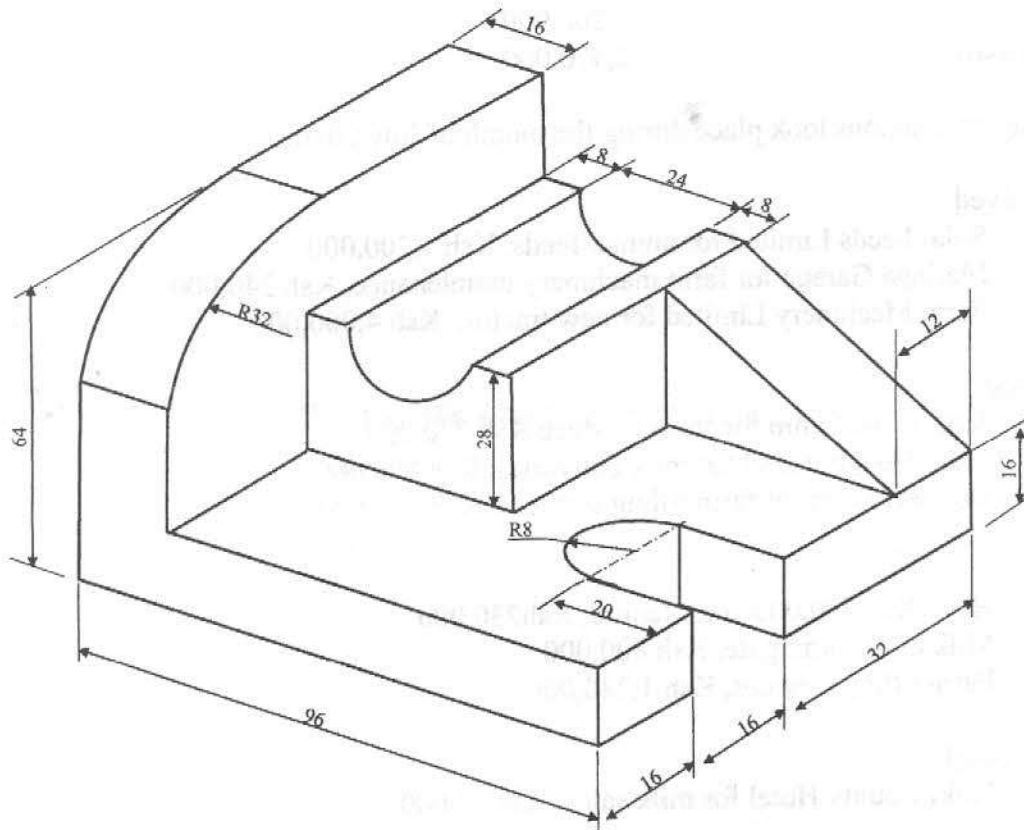

Figure 1

- (ii) Fully dimension the drawing as it appears. (6 marks)
- (c) Enlarge the 3D drawing by scale factor 1:3 about the lowest corner of the figure. (2 marks)
- (d) Save the drawing as 3Dblock in the **KNECEXAM** folder to print out later. (1½ marks)

TASK 2

Kulima Farm Limited of P. O. Box 48251-00400 Nakuru, is a farm engaged in mixed farming. Record the following financial details and transactions of the company using a suitable accounting package for the year starting July 1, 2016.

Balances as at 1st July 2016	Ksh
Farm House	2,000,000
Farm Machinery: Cost	6,200,000
Depreciation	2,700,500
Motor Vehicles: Cost	2,200,000
Depreciation	1,930,000
Creditors: Mifugo Feeds	1,200,000
Farm Machinery Limited	1,800,000
Debtors: Jaru Safari Camp	800,000
Moto Travellers Hotel	300,000
Bank(Yako)	-800,000
Cash	208,900
Bank loan(Yako)	2,470,000

The following transactions took place during the month of July 2016.

Invoices received

July 1	Solai Feeds Limited for animal feeds, Ksh 1,200,000
July 10	Matinga Garage for farm machinery maintenance, Ksh 340,000
July 28	Farm Machinery Limited for new tractor, Ksh 4,000,000

Invoices Issued

July 18	Jaru Safari Camp for fresh produce Ksh 720,000
July 20	Laiki County Hotel for milk deliveries, Ksh 800,000
July 25	Dundori Farm for farm tilling services, Ksh 400,000

Cash Sales

July 09	Hay, Ksh 600,000 and Manure, Ksh 230,000
July 21	Milk at the farm gate, Ksh 800,000
July 30	Farm tilling services, Ksh 1,240,000

Debit Notes Issued

July 24	Laiki County Hotel for milk sales, Ksh 50,000
---------	---

Cash payments

July 14	Wages, Ksh 180,000
July 18	Loan Interest Yako bank, Ksh 175,000
July 29	Electricity Ksh 4,000, farm machinery maintenance, Ksh 168,000

Cheque receipts

July 20	Jaru Safari Camp, Ksh 1,400,000
July 28	Moto Travellers Hotel Ksh 156,000
July 31	Laiki county Hotel Ksh 500,000

Cheque payments

July 26 Farm Machinery Limited Ksh 2,000,000
July 31 Mifugo Feeds Ksh 600,000
July 31 Bank loan repayment Ksh 102,000

Generate and print the following reports

- (a) Opening Balance sheet ; (6 marks)
- (b) Income statement for the month of July; (6 marks)
- (c) Closing trial balance. (8 marks)

THIS IS THE LAST PRINTED PAGE.