

2920/202B  
COMPUTER APPLICATIONS II  
(PRACTICAL)  
Paper 2  
March/April 2023  
Time: 1 hour



THE KENYA NATIONAL EXAMINATIONS COUNCIL

DIPLOMA IN INFORMATION COMMUNICATION TECHNOLOGY

MODULE II

COMPUTER APPLICATIONS II

Practical

Paper 2

1 hour

233

### INSTRUCTIONS TO CANDIDATES.

You have **ten** minutes to read through the instructions and questions before starting the examination.

Any problem with the computer should be reported to the invigilator immediately.

Direct any question(s) to the invigilator only. Conversing with fellow students may lead to disqualification.

Write your **name** and **index number** on the rewritable CD.

Type **your name** as a header on each sheet of paper used.

This paper consists of **TWO** tasks. Perform the **TWO** tasks.

Each task carries **20** marks.

Read the instructions of each task carefully.

Print on **one** side of the paper(s) only and use a fresh sheet of paper for each task.

Hand over your **printout** and the **Rewritable CD** to the invigilator at the end of the examination.

This paper consists of 5 printed pages.



Candidates should check the question paper to ascertain that all the pages are printed as indicated and that no questions are missing.

**GENERAL INSTRUCTIONS TO CANDIDATES**

1. Create a folder named **KNECEXAM** on the desktop.
2. Ensure that the **KNECEXAM** folder and all its content is burnt onto the Rewritable CD provided at the end of the examination.



**TASK 1**

- (a) Open a computer aided design program and make the following drawing settings:
- (i) Units: millimetres; (½ mark)
- (ii) Precision: 0 decimal place. (½ mark)
- (b) Insert two layers each with the following properties: (1 mark)

Layer name	Line weight
Outline	0.8 mm
Dimension	0.2 mm

- (c) (i) Figure 1 shows a 3-D wooden block. Draw the figure as it appears on the outline layer using the dimensions indicated. (10½ marks)

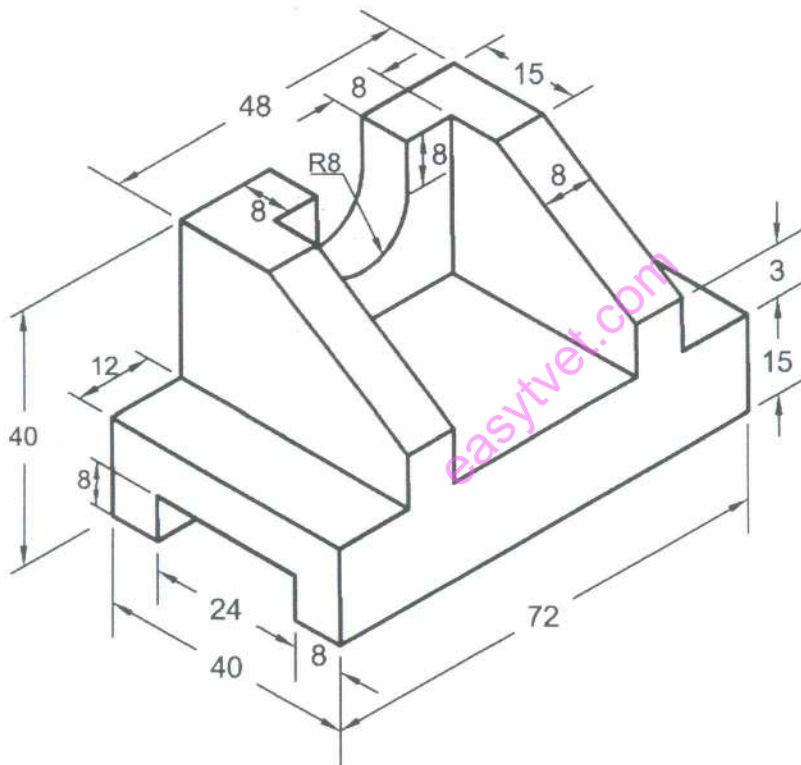

Figure 1

- (ii) Fully dimension the drawing on the *dimension* layer. (5½ marks)
- (d) Save the drawing as *wooden block* in the **KNECEXAM** folder. (1 mark)
- (e) Print out later the drawing. (1 mark)



**TASK 2**

Intellect Management Limited of P. O. Box 34010 – 00400, Mombasa, provides intellectual property consultancy services to clients and intends to computerize its accounting records. Record the following financial details and transactions relating to the company for the year starting 1<sup>st</sup> September, 2021.

**Balances as at 1<sup>st</sup> September, 2021**

		<b>Kshs</b>
Staff van	Cost	2,350,000
	Depreciation	870,000
Premises	Cost	2,600,000
Furniture/fittings:	Cost	1,205,000
	Depreciation	430,500
Office equipment:	Cost	400,750
	Depreciation	109,500
Debtors:	Overseas Services Ltd	298,400
	Resource Associates Ltd	420,800
Creditors	Muga & Muga Advocates	900,500
	Overdue rent	200,000
Cash		158,200
Bank (current account)		246,000

233 The following transactions took place during the month of September:

- Sept 1 Paid the following expenses by cash:  
     Legal fees Ksh 140,000.  
     Telephone Ksh 16,250.
- Sept 2 Invoiced Forthright International Ltd Ksh 480,000 for company patent registration.
- Sept 3 Paid salaries for the month of August Ksh 325,000 by cheque.
- Sept 4 Contracted by Terry Products Manufacturers to carry out an investigation on trademark infringement at a cost of Ksh 1,200,000.
- Sept 5 Paid Muga & Muga Advocates on account Ksh 250,000 by cheque.
- Sept 6 Received a cheque of Ksh 200,000 as part instalment from Forthright International Ltd for services rendered.
- Sept 7 Hired Mataga Associates for secretarial services at a cost of Ksh 100,500 on behalf of Mineral Prospects International Ltd. The company had charged Mineral Prospects International Ltd Ksh 280,000 for the service and paid by cheque.
- Sept 8 Paid office rent Ksh 200,000 by cheque.
- Sept 10 Intellect Management Limited contracted Muga & Muga Advocates to represent their client in court for patent defence against infringement by a local company at a cost of Ksh 622,000 on credit.
- Sept 14 Terry Products Manufacturers contracted Intellect Management for registration of a product design at a cost of Ksh 1,200,000 on credit.
- Sept 16 Received the following payments by cheque;  
     Resource Associates Ltd Ksh 420,800.  
     Terry Products Manufacturers Ltd Ksh 600,000.





- Sept 18 Paid the following:  
Muga and Muga Associates Ksh 350,000 by cheque;  
Patent registration fees Ksh 120,000 by cash.
- Sept 26 Bought an office safe worth Ksh 140,000 by cheque.
- Sept 30 Received electricity and water bills for the month of September of Ksh 18,640, and Ksh 12,420 respectively and paid them by cash on the same day.

Generate and print out each of the following reports:

- (a) The trial balance as at 1<sup>st</sup> September; (8 marks)
- (b) The profit and loss account for the month; (6 marks)
- (c) The balance sheet as at 30<sup>th</sup> September 2021. (6 marks)

THIS IS THE LAST PRINTED PAGE.

easyvet.com

