



**REPUBLIC OF KENYA**

**LEARNING GUIDE**

**FOR**

**ELECTRICAL INSTALLATION LEVEL3**



TVET CDACC  
P.O BOX 15745-00100

NAIROBI

[easytvvet.com](http://easytvvet.com)

First published 2020  
Copyright TVET CDACC

All rights reserved. No part of this Learning Guide may be reproduced, distributed, or transmitted in any form or by any means, including photocopying, recording, or other electronic or mechanical methods without the prior written permission of the TVET CDACC, except in the case of brief quotations embodied in critical reviews and certain other non-commercial uses permitted by copyright law. For permission requests, write to the Council Secretary/CEO, at the address below:

**Council Secretary/CEO**  
**TVET Curriculum Development, Assessment and**  
**Certification Council**  
**P.O. Box 15745–00100**  
**Nairobi, Kenya**  
**Email: [info@tvetcadacc.go.ke](mailto:info@tvetcadacc.go.ke) / [cdacc.tvet@gmail.com](mailto:cdacc.tvet@gmail.com)**  
**Website: [www.tvetcadacc.go.ke](http://www.tvetcadacc.go.ke)**

*easytvvet.com*

## **FOREWORD**

The provision of quality education and training is fundamental to the Government's overall strategy for social economic development. Quality education and training will contribute to achievement of Kenya's development blue print and sustainable development goals. Reforms in education are necessary to align the sector to the provisions of the Constitution of Kenya 2010. This triggered the formulation of the Policy Framework on "Reforming Education and Training in Kenya" (Sessional Paper No. 1 of 2019). A key provision of this policy is the radical change in the design, development and delivery of Technical and Vocational Education and Training (TVET) which is the key to unlocking the country's potential for industrialization. This policy requires that training in TVET be Competency Based, Curriculum development be industry led, certification be based on demonstration of competence and that mode of delivery allows for multiple entry and exit in TVET programs.

The State Department for Vocational and Technical Training (VTT) has a responsibility of facilitating the process of inculcating knowledge, skills and attitudes necessary for catapulting the nation to a globally competitive country, hence the paradigm shift to embrace Competency Based Education and Training (CBET) to address the mismatch between skills acquired through training and skills needed by industry as well as increase the global competitiveness of Kenyan labor force. The Technical and Vocational Education and Training Act No. 29 of 2013 and the Sessional Paper No. 1 of 2019 on Reforming Education and Training in Kenya, emphasizes the need to reform curriculum development, assessment and certification to respond to the unique needs of the industry.

This learning guide has been developed to support the implementation of CBET curriculum in Electrical Installation Level 3 and is intended to guide the trainee through the learning process. It is my conviction that this learning guide will play a critical role towards supporting the development of competent human resource for Electrical Installation sector's growth and sustainable development.

**PRINCIPAL SECRETARY, VOCATIONAL AND TECHNICAL TRAINING  
MINISTRY OF EDUCATION**



## PREFACE

Kenya Vision 2030 is anticipated to transform the country into a newly industrializing, “middle-income country providing a high-quality life to all its citizens by the year 2030”. The Sustainable Development Goals (SDGs) number four that focuses on inclusive and equitable quality education and promotion of lifelong learning for all, further affirm that education and training is an important driver to economic development for any country. Kenya intends to create a globally competitive and adaptive human resource base to meet the requirements of a rapidly industrializing economy.

TVET CDACC has a responsibility of facilitating the process of inculcating knowledge, skills and attitudes necessary for catapulting the nation to a globally competitive country, hence the paradigm shift to embrace Competency Based Education and Training (CBET) to address the mismatch between skills acquired through training and skills needed by industry as well as increase the global competitiveness of Kenyan labor force. The Technical and Vocational Education and Training Act No. 29 of 2013 and the Sessional Paper No. 1 of 2019 on Reforming Education and Training in Kenya, emphasizes the need to reform curriculum development, assessment and certification to respond to the unique needs of the industry.

To effectively implement CBET curriculum in Electrical Installation Level 3, this learning guide has been designed and organized with clear interactive learning activities for each learning outcome of every unit of learning. The guide further provides information sheet, self-assessment items, tools, equipment, supplies, and materials necessary for the particular learning outcome. This is aimed at imparting the relevant knowledge, requisite skills and the right attitude for work.

I am grateful to the trainers involved in the development of this learning guide.

**Prof. CHARLES M. M. ONDIEKI, PhD, FIET (K), Con. Eng. Tech. CHAIRMAN,  
TVET CDACC**

[easytvvet.com](http://easytvvet.com)

## ACKNOWLEDGEMENT

This learning guide has been designed and developed to support the implementation of Competency Based Education and Training (CBET) curricula in Kenya. The learning guide is intended to support learning by providing practical and theoretical learning activities, simplified content and self-assessment items to guide the trainee in the learning process.

I recognize with appreciation the critical role of trainers in developing this learning guide and ensuring its alignment with National Occupational Standards (OS) and CBET curriculum. I am convinced that this learning guide will support trainees' acquisition of knowledge, skills and right attitude needed for work in the Electrical Installation sector.

**DR. LAWRENCE GUANTAI M'ITONGA, PhD**  
**COUNCIL SECRETARY/CEO**  
**TVET CDACC**

*easytvvet.com*

## ACRONYMS

CBET	: Competence Based Education and Training
VTT	: Vocational and Technical Training
CEO	: Chief Executive Officer
CDACC	: Curriculum Development, Assessment and Certification Council
TVET	: Technical and Vocational Education and Training
SSAC	: Sector Skills Advisory Committee
OS	: Occupational standards
SDGs	: Sustainable Development Goals
OSHA	: Occupational Safety and Health Act
NEMA	: National Environmental Management Authority
NCA	: National Construction Authority
IEE	: Institute of Electrical Engineers
IET	: Institution of Engineering and Technology
CNC	: Computer Numerical Control
OSHS	: Occupation Safety and Health Standards
PPE	: Personal Protective Equipment
SOPs	: Standard Operating Procedures
SSAC	: Sector Skills Advisory Committee
KNQA	: Kenya National Qualification Authority
ICT	: Information Communication Technology
KCSE	: Kenya Certificate of Secondary Education
KCPE	: Kenya Certificate of Primary Education
PVC	: Polyvinyl Chloride
ENG	: Engineering
RCD	: Residual Current Device
ICTP	: Iron Clad Triple Pole
M.C.B.	: Miniature Circuit Breaker
PC	: Performance Criteria
EI	: Electrical Installation
BC	: Basic Units
LG	: Learning Guide
CR	: Core Competency
CPU	: Central Processing Units
CU	: Curriculum
A	: Control Version

## TABLE OF CONTENT

FOREWORD	iii
PREFACE	iv
ACKNOWLEDGEMENT	v
ACRONYMS	vi
TABLE OF CONTENT	vii
LIST OF FIGURES	ix
LIST OF TABLES	xiii
<b>CHAPTER ONE: PVC SHEATHED CABLING, CONDUITING, TRUNKING AND CABLE TRAYS LAYING</b>	<b>1</b>
1.0. Apply workplace safety	1
1.1. Perform Basic Metal Works	24
1.2. Install PVC Sheathed cable	43
1.3. Install electrical metallic/non- metallic (PVC) conduits	56
1.4. Install Wire Ways, Trunking and Cable Trays	90
1.5. Install distribution board frames and auxiliary components	101
<b>CHAPTER TWO: SINGLE PHASE ELECTRICAL INSTALLATION AND MAINTENANCE</b>	<b>111</b>
2.0. Interpret electrical drawings	111
2.1. Select Correct Types and Sizes of Cables	147
2.2. Install Cables for Lighting and Power Points	159
2.3. Install consumer's control unit	179
2.4. Inspect and test the complete installation	188
2.5. Repair and maintain the installation	192
<b>CHAPTER THREE: FIXING AND MAINTENANCE OF LIGHT FITTINGS, POWER OUTLETS AND BASIC APPLIANCES</b>	<b>197</b>
3.0. Apply workplace safety	198
3.1. Select wiring devices	209
3.2. Install wiring devices, lighting fixtures and basic appliances	221

[easytvvet.com](http://easytvvet.com)

## LIST OF FIGURES

Figure 1: Basic PPE for Electrical Operator	2
Figure 2: Demonstration of Electrical Shock	11
Figure 3: Combination Square used for transferring design	24
Figure 4: A Caliper for Measuring Length	25
Figure 5: A Sand- Casting Mold	27
Figure 6: A Metal Spun brass vase	29
Figure 7: A CNC Plasma Cutting Machine	30
Figure 8: A Milling Machine in Operation, including Coolant Hoses	31
Figure 9: A Lethe Cutting Material from a Workpiece	33
Figure 10: Three Different Types and Sized of Taps	34
Figure 11: Grinding	35
Figure 12: Filing	36
Figure 13: Mig Welding	37
Figure 14: Soldering a Printed Circuit Board	38
Figure 15: Parts of PILC Cables	46
Figure 16: Flexible Cable	48
Figure 17: House Service Overhead System	49
Figure 18: House Service Overhead System	50
Figure 19: A Diagram on Advantaged of MI Cable	52
Figure 20: Electrical Symbols	58
Figure 21: Layout drawing for electrical installation	59
Figure 22: Threading Steel Conduit	61
Figure 23: Distance Saddles	63
Figure 24: Multiple Saddles	64
Figure 25: Coupling and Mable Bush Method	64
Figure 26: Locknut and Female Brass Bush Method	65
Figure 27: Galvanized Steel Conduit Accessories	65
Figure 28: Jointing Steel Conduit	66
Figure 29: Bending Steel Conduit	68

Figure 30: Forming of a 30 Degrees Offset	69
Figure 31: Forming a 45 Degrees Offset	71
Figure 32: Making a Double 90 Degrees Bend on a Steel Conduit	73
Figure 33: Step 1, Anchor Boxes	75
Figure 34: Step 2, Measure Conduit	75
Figure 35: Step 3, Cut Conduit	76
Figure 36: Step 4 Slide in Conduit	76
Figure 37: Step 5 Anchor Conduit	77
Figure 38: Additional Step to Install a Pulling Elbow	78
Figure 39: Fitting and Fixing of PVC Conduit	79
Figure 40: Choosing the Right Material for Installing Electrical Conduit Fittings	82
Figure 41: Chalk out a wiring plan	82
Figure 42: Measure the amount of conduit that you would need	83
Figure 43: Step 4, Make the necessary bends	83
Figure 44: Step 5, Attach fittings to the Wall	84
Figure 45: Step 6, Tape the end and put the wires in place	84
Figure 46: Step, Install Raceway Starter Box	85
Figure 47: Light Trunking	92
Figure 48: Cable Trunking	93
Figure 49: Multi-Compartment trunking	94
Figure 50: Forming a T-Joint	96
Figure 51: Forming an Internal Bend	97
Figure 52: Residential DB	101
Figure 53: TT Network	106
Figure 54; Identification of Circuits	113
Figure 55: Identification of Switch lines and ceiling rose	114
Figure 56: Switch	116
Figure 57: Bed Switch	116
Figure 58: Rotary Switch	117
Figure 59: Push Button Switch	117



Figure 60: Batten Lamp Holder	118
Figure 61: Pendant Holder	119
Figure 62: Angle Lamp Holder	119
Figure 63: Swivel Lamp holder	120
Figure 64: Bracket Lamp Holder	120
Figure 65: Fluorescent Lamp (Tube) Holder	121
Figure 66: Ceiling rose	121
Figure 67: Socket	122
Figure 68: Pin Switch	122
Figure 69: Main Switch	123
Figure 70: I.C.T.P Switch	123
Figure 71: Cut Out Fuse	124
Figure 72: Miniature Circuit Braker	125
Figure 73: Electrical Installation Drawing symbols	126
Figure 74: Machined Block	126
Figure 75: Isometric Drawing	127
Figure 76: Closed and Open Circuit	141
Figure 77: Series and Parallel Circuits	142
Figure 78: Circuit Diagram	143
Figure 79: Parts of a Machine	145
Figure 80: Effects of Temperature to Conductors	149
Figure 81: Bell hangers joint	160
Figure 82: Western Union Splice cable joint	160
Figure 83: Solar home system layout	163
Figure 84: Pliers	165
Figure 85: Layout of a Consumer intake point and two final circuits	177
Figure 86: Neutral and Earth terminals	179
Figure 87: Sequence of Control for a very basic distribution board	180
Figure 88: Conductor buried below the level of the foundation	182
Figure 89: Earthing rods connected in parallel	183

Figure 90:Vertical plate	184
Figure 91: Consumer's Intake Point	187
Figure 92: Switches	211
Figure 93: MCB Distribution Box	215
Figure 94: Conduiting Wiring	216
Figure 95: Conduit Wiring Components	216
Figure 96: One Lamp Controlled by two switches	221
Figure 97: Track Lighting	223
Figure 98:Recessed and Under-Cabinet Lighting	224
Figure 99: Pendants lighting	224
Figure 100: Chandaria Lighting	225
Figure 101: Wall Sconces lighting	225
Figure 102: Electrical System Without Earthing	231
Figure 103: Electrical system with Earthing	231
Figure 104: Earth Mat	233
Figure 105: Earth Test System	236
Figure 106:Insulation Megger testing of machine to panel board	240

## LIST OF TABLES

Table 1: Use of Fire Extinguishers	16
Table 2: Visit to an Electrical Workshop	21
Table 3: Compatibility Chart of Material versus Processes	27
Table 4: The Maximum distance between supports for steel trunking	95
Table 5: Summary of Networks	107
Table 6: Installation drawing symbols	210
Table 7: Colour codes	236
Table 8: Colour scheme for labels	238

[easytvvet.com](http://easytvvet.com)

# CHAPTER ONE: PVC SHEATHED CABLING, CONDUITING, TRUNKING AND CABLE TRAYS LAYING

**Unit Code** ENG/LG/EI/CR/01/3/A

## **Relationship to Occupational Standards**

This unit addresses the Unit of Competency: Perform PVC sheathed cabling, conduiting, trunking and cable trays laying

## **Introduction**

This unit describes the competencies required by an electrician in order to safely install electrical metallic and non-metallic conduits, trunking, cable trays, wire ways and distribution board frames based on the required performance standards.

## **Summary of Learning Outcome**

1. Apply workplace safety
2. Perform basic metal works
3. Install PVC Sheathed cables
4. Install electrical metallic/non-metallic (PVC) conduits
5. Install wire ways, trunking and cable trays
6. Install distribution board frames and auxiliary components

### **1.0. Apply workplace safety**

#### **Introduction**

This learning outcome specifies the competences required to apply work place safety, learn causes of accidents and how to prevent them.

#### **Performance Standard**

- Correct PPE are identified and selected in line with safety requirements.
- Workshop safety are applied in line with the workshop rules and regulations
- First Aid is carried out according to the standard operating procedures
- Workshop hazards are classified in accordance with OSHA

#### **Information Sheet**

##### **Personal Protective Equipment (PPE)**

##### **Meaning and purpose of PPE**

Personal protective equipment (PPE) is protective clothing, helmets, goggles, or other garments or equipment designed to protect the wearer's body from injury or infection. The hazards

addressed by protective equipment include physical, electrical, heat, chemicals, biohazards, and airborne particulate matter.

### **Types of PPE**

Depending on the job task to be performed, PPE for the electric power industry generally includes safety glasses, face shields, hard hats, safety shoes, insulating (rubber) gloves with leather protectors, insulating sleeves, and flame-resistant (FR) clothing



Figure 1: Basic PPE for Electrical Operator

### **Safe and correct handling of different types of PPE**

The PPE must be inspected for defects every time it is put on. Look for symmetry; does each side look like a mirror image of the other or is one side distorted? Are there any broken, bent, frayed or torn pieces? Are the lenses scratched so they are hard to see through? Is the elastic still springy or is it stretched out? In addition to visual inspection as above, insulating gloves, sleeves and blankets for electrical workers must be electrically tested. All must be tested prior to initial use, and then every 6 months thereafter for gloves, and every 12 months for sleeves and blankets. PPE should be clean. If dirty, clean it with soap and warm water. Do not use solvents or abrasives to clean it. Store it out of sunlight in an area where it will be protected and kept clean. Replace reusable PPE every 2-5 years, earlier if recommended by the manufacturer or if there is a major impact. Replace any defective parts with parts made by the same manufacturer for that equipment. Do not make makeshift repairs. If it cannot be repaired properly, replace it. Do not use paint or glue on PPE. Use decals or stickers to mark it.

### **Safety and Environmental Regulations**

#### **Workshop safety**

The safety in Workshops has been written not only to provide appropriate safety procedures but also to assist trained workshop personnel with the provision of a reference document outlining the general principles of safe working practices relevant to the mechanical engineering aspects. It relates to specific areas where definite safety measures are required for workshop operations

## **Factories Act and Accident**

Various acts relating to accidents are spelt out in workmen's compensation Act-1923. The factories act-1948 and Fatal Accidents Act-1855. These acts describe the regulations for fencing and guarding the dangerous machinery, items and employer's liabilities.

### **Introduction to workshop safety**

A workshop is where you learn to use tools and machines to make things; It can be a dangerous place, so you must learn the safety rules for the workshop.

The safety rules tell you how to dress appropriately and how to behave whilst working with tools that may cause harm. You must never play in the workshop, run around or throw equipment to one another.

### **Personal safety:**

The basic dress rules that you should always follow are:

- i.** Proper clothing.  
You must not wear loose clothes that can be caught in moving machinery. You must wear tight fitting overalls.
- ii.** Proper eye protection.  
You must always wear goggles to protect your eyes while you are working in the workshop.
- iii.** Remove tie and jewelry.  
Ties, watches, rings and other jewelers increase the chance of getting caught by moving machinery. You must remove them before entering the workshop.
- iv.** Cut or secure long hair. Long hair is also dangerous as it may be caught by the machine and pulls you into it.
- v.** Proper shoes. You must not wear sandals or soft shoe inside the workshop as they will not protect your feet from falling objects. A safety shoes (steel-toe shoes) will protect your feet if you accidentally drop something.
- vi.** The way you dress in the workshop is very important for your safety, always be sure to wear properly and encourage your friends to do the same.

### **General workshop safety**

It's essential to be aware of and able to foresee the dangers which exist in the workshop and are likely to affect your health and safety.

You should make sure that your workspace is as safe as possible so that few dangers arise.

- i) Use the appropriate protective clothing and equipment to minimize the risk of accident
- ii) Act in a safe manner at all times.

### **General Safety Precautions while Working in a Workshop**

- i. One should not leave the machine ON even after the power is OFF and until it has stopped running completely. Someone else may not notice that the machine is still in motion and be injured.
- ii. Operator should not talk to other industrial persons when he is operating a machine.
- iii. One should not oil, clean, adjust or repair any machine while it is running. Stop the machine and lock the power switch in the OFF position.
- iv. One should not operate any machine unless authorized to do so by the authorize person in the shop.
- v. Always check that work and cutting tools on any machine are clamped securely before starting.
- vi. The floor should be kept clean and clear of metal chips or curls and waste pieces. Put them in the container provided for such things. Scraps and chips or curls may cut through a shoe and injure the foot.
- vii. Defective guards must be replaced or repaired immediately.
- viii. One should not operate any machinery when the supervisor or instructor is not in the shop.
- ix. All set screws should be of flush or recessed type. Projecting set screws are very dangerous because they catch on sleeves or clothing.
- x. One should not try to stop the machine with hands or body.
- xi. Only trained operator should operate machine or switches as far as possible.
- xii. Always take help for handling long or heavy pieces of material.
- xiii. Always follow safe lifting practices
- xiv. No one should run in the shop at work time.
- xv. Always keep your body and clothes away from moving machine parts. Get first aid immediately for any injury.
- xvi. Never talk to anyone while operating the machine, nor allow anyone to come near you or the machine.
- xvii. Stop the machine before making measurements or adjustments.
- xviii. Operator should concentrate on the work and must not talk unnecessarily while operating the machines.
- xix. Never wear necktie, loose sweater, wristwatch, bangles, rings, and loose-fitting clothing while working in workshop.
- xx. Always wear overcoat or apron.
- xxi. Stop machines before attempting to clean it.
- xxii. Make sure that all guards are in their place before starting to operate a machine.
- xxiii. Do not attempt to operate a machine until you have received operating instructions.
- xxiv. Be thoroughly familiar with the 'stop' button and any emergency stop buttons provided on the machines.
- xxv. Remove burrs, chips and other unwanted materials as soon as possible. They can cause serious cuts.

- xxvi. Do not leave loose rags on machines.
- xxvii. Wash your hands thoroughly after working to remove oils, abrasive particles, cutting fluid, etc.
- xxviii. Report all injuries to the foreman, howsoever small. Cuts and burns should be treated immediately.
- xxix. Keep the work area clean.
- xxx. Keep your mind on the job, be alert, and be ready for any emergency.
- xxxi. Always work in proper lighting.
- xxxii. One should not lean against the machines.

### **Concept of accident**

It is very difficult to give a definition of the word 'Accident'. However, a generally accepted conception that an accident is a mishap, a disaster that results in some sort of injury, to men, machines or tools and equipment and in general loss to the organization. The said injury or loss may be of minor or major nature and the accident is termed as non-reportable or reportable. For example, a small cut on the body will be reportable accident in a training workshop. It can be treated by first aid and does not involve any appreciable loss of time, and will not be considered a reportable accident in a production unit.

### **Causes of accidents**

The 98% accidents could be easily avoided provided due precautions are taken well in time. A very familiar slogan goes on to say that accidents do not just happen but are caused due to the failure of one element or the other, and the most unfortunate factor is that the human element is the most pronounced of all which fail.

The common causes which lead to accidents are the following:

1. Unsafe working position.
2. Improper or defective tools or their improper use.
3. Improper acts- which result in violation of safety rules and non-observance of safety precautions.

### **Causes of accidents**

#### **1. Causes due to human beings**

##### **a) Carelessness**

This is due to overconfidence, loss of interest, fatigue (continuous work without rest), monotony, unnecessary emotion which diverts concentration on the work being done hence resulting to accidents.

##### **b) Ignorance**



An operator must understand the users and the function of his machine equipment.

**c) Unsuitable PPEs in working areas**

Personnel should wear clothing which will provide protection against dangers in areas where they work. That is:

**i. Safety Shoes/boots.** They should be a type which provides protection against slippery conditions.

They should be strong enough in the feet to prevent injury from hurting objects e.g. safety boots.

**ii. Gloves-** They should be worn where there are risks when harming sharp objects whether inside or outside buildings.

**iii. Safety glass**

Safety glasses or goggles should be worn where there's likely of danger to the eyes, such as using drills, grinding machines etc.

**d) Untidiness**

**i.** Keep all passage ways clear and clean.

**ii.** Circular rods if stepped upon can cause nasty falls.

**iii.** Keep the workshop floor free from grease and oils.

**2. Contributing causes**

**a) Unsatisfactory hand tools like being worn out without handles**

**i.** Hammers with loose handles or crippled faces should never be used.

**ii.** Chisels with burred heads are dangerous as broken pieces from the edges may fly off and cause injury.

**iii.** Files should have tight handles to prevent accidents to the hands.

**iv.** Spanners which fit incorrectly will slip and can result in damaging fingers.

**v.** When drilling always ensure that the work is securely held in a vice or otherwise securely clamped.

**b) Unsatisfactory machines**

**i.** That is being insufficiently spaced, unguarded, broken, improperly adjusted, insufficiently lubricated and being too small or weak for the job being undertaken.

**ii.** All machines are properly guarded, all abrasive wheels are kept in good condition and run at safe speeds.

**iii.** Don't attempt to adjust or remove by hand a belt on a rotating shaft.

**iv.** don't allow idle belt to rest on rotating shaft and don't attempt to oil overhead shafting while it's in motion.

**c) Should never be overloaded.**

Physical condition of personnel while working like before lifting equipment ensure that the weight is within your capability to handle. A base that anything used for lifting is serviceable and in good working condition chains, hooks etc.

### **Common sources of accidents**

The large number of machines in use and an even larger number of parts. This can be regarded as sources of danger and require guarding for protection against accidents.

#### **Some common sources of accident are as listed below:**

Projecting nips between sets of revolving parts, viz, gears, rolls and friction wheels, etc.

- i. Projecting fasteners on revolving parts.
- ii. Revolving cutting tools, circular saw blades.
- iii. Revolving drums, crushers, spiked cylinder and armed mixers, etc.
- iv. Revolving shafts, spindles, bars and tools like drills, reamers, boring bars and chucks, etc.
- v. Projecting sharp edges or nips of belt and chain drives viz., belt, pulleys, chains, sprockets and belt fasteners.
- vi. Reciprocating tools and dies of power presses, drop hammers, and revolving presses, etc.
- vii. Grinding wheels and stones.
- viii. Reciprocating knives and saw blades such as cutting and trimming machines and power hack-saws, etc.
- ix. Revolving drums and cylinders without casing, such as concrete and other mixers.
- x. Intermittent feed mechanisms.
- xi. Projecting nips between various links and mechanisms, like cranks connecting rods, piston rods, rotating wheels and discs, etc.

### **Common Methods of Protection**

The common methods of protection against accidents are the following:

- i. Safety by position.
- ii. Safety by construction.
- iii. Safety by using interlock guards.
- iv. Safety by using fixed guards.
- v. Safety by using automatic guards.
- vi. Safety by using distance guards.

### **Safety by construction**

When a new machine is designed, it should be ensured that all its dangerous parts are either enclosed in suitable housings or provided with suitable safety guards. For example, the belt drive and motor in a lathe or milling machine are enclosed; the back gears in a lathe are either enclosed or provided with cast iron guards or covers. Lubricating points are provided on the outer surfaces so that the interior parts are not required to be opened every time.

### **Safety by position**

The machine design is in such a way that the dangerous parts are located such that they are always beyond the reach of the operator. The dangerous parts of all the machines should invariably be guarded and undertaking should be made to make them enclosed in the body or housing of the machines.

### **Safety by using interlock guards**

It is a very efficient and sound method of guarding in that the guard cannot be removed and dangerous parts exposed until and unless the machine is totally stopped. Similarly, the machine cannot be started to work unless the guard returns in position and protects the dangerous parts. An interlocking guard may be mechanical, electrical or some sort of a combination of these. It is essential that it should:

- i. Prevent the starting and operation of the machine in case the interlocking device fails.
- ii. Always acquire its position to guard the dangerous part before the machine can be started.
- iii. Remain closed in position until the dangerous part is completely at rest.

### **Safety by using fixed guards**

These guards either form an integral part of the machine or are tightly secured to them. They should be made to have rigid construction and should be so placed that any access to the dangerous parts of the machine is totally prevented in the running condition of the machines. Steel sheets can be advantageously used and they facilitate an easy fabrication of guards and are lighter in weight.

In some cases, the fixed guards are made adjustable in order to accommodate different kinds of works or sets of tools. In some cases, the fixed guards are provided at a distance from the danger point.

### **Safety by using distance guards**

The principle of a distance guard is that a fencing, enough high, is made of bars, at a suitable distance from the machine such that even if the operative, by chance, extends his hands over it, his fingers, clothes or any part of the body does not reach within the area of dangerous parts. An additional measure of safety, some sort of tripping device is also usually incorporated to stop the machine quickly in case of an accident.

### **Safety by using automatic guards**

The principle of an automatic guard is that its operation is actuated by some moving part of the machine.

It may link that the part will automatically bring the guard in protecting position before the operation of the machine starts. The design of the guard is such that it automatically forces the operative away from the dangerous area of work before the operation starts and does not permit

his access to the area again until and unless the machine stops. It may be noted that due to enough time being required for their operation, this type of guards are not suitable for quick-acting and fast-running machines. Their use is largely favored for heavy and slow acting machines like heavy power presses.

### **Industrial safety**

The factory act 1961 states that:

- i. Floors steps stairs passages and gang ways must be soundly constructed properly maintained and kept free from obstruction and any substance likely to cause a person to slip.
- ii. Hand rails must be provided for stairs.
- iii. All ladders must be soundly constructed and properly maintained.
- iv. Opening in floors shall, wherever practicable be securely fenced.

### **Special regulations**

The following precautions should be observed

- i. Always work never runs
- ii. Never throw rubbish on the floor
- iii. Keep gang ways and work areas free of metal bars, components, etc.
- iv. Keep to gangways when moving about never takes short cuts.
- v. If oil water or grease is spilled wipe it up immediately
- vi. Wear safety shoes- shoes are available with anti slip soles and with metal toe caps to protect the feet from falling objects.
- vii. Always check ladders for damage before use.
- viii. Always position ladders on firm base at the correct angle.

### **Aims and objectives**

The major objectives of the factory act are;

- i. To provide protection to the workers employed in factories against industrial hazards and to ensure safe and better working conditions.
- ii. It regulates and maintains properly various safety health and welfare activities in the factories.
- iii. It regulates & maintains working hours of workers, employment of children and adolescents, employment of women, annual leave with wages etc.

### **The salient features of this act regarding safety are as follows;**

- i. Fencing of machinery  
Every prime mover like engine or motor, moving part of the machinery is fenced properly.
- ii. Work on or near the machinery in motion.  
Only specially trained workers wearing tight fitting clothes should carry out inspection of any part of the machinery in motion.

- iii. Employment of young persons on dangerous machines.
- iv. No young person should be allowed to work on dangerous machine unless he is properly trained and carefully supervised
- v. Hoist and lifts.
- vi. Every hoist and lifts should be of good mechanical construction, adequate strength and must be protected by enclosure and fitted with gates.  
Every hoist and lift should be adequately maintained and periodically examined
- vii. Lifting machinery, chains, ropes and lifting tackles  
Lifting machines such as cranes, crab, etc should be of good construction, adequate strength should be maintained.
- viii. Revolving machinery  
It should always be ensured that safe working peripheral speed is not exceeded for every revolving machinery.
- ix. Pressure plants.  
The pressure plant should not be operated at a pressure higher than the specified safe working pressure.
- x. Floors stairs and means of access to different places  
All floors, steps, stairs, passages should of sound construction and free from obstructions
- xi. Pits sumps, opening in floor etc.  
Every pit, sumps, opening in floor, fixed vessels, tanks etc should be securely covered or fenced.
- xii. Excessive weights  
No person should be asked to lift carry or move any load so heavily that's likely to cause him injury. Protection of eyes.

### **Accident reports**

Every accident must be reported to an employer and the details of the accident and treatment given are suitably documented. A first aid Log book or accident book containing first aid treatment record sheets could be used to effectively document accidents which occur in the workplace and the treatment given. Failure to do so may influence the payment of compensation at a later date if an injury leads to permanent disability.

To comply with the Data Protection Regulations, from the all First Aid Treatment Log books or Accident Report books must contain perforated sheets which can be removed after completion and filed away for personal security.

### **Environment Management and Coordination Act (EMCA)**

#### **General principles**

Entitlement to a clean and healthy environment

#### **Protection and conservation of the environment**

No person shall, without the prior written approval of the Director-General given after an environmental impact assessment, in relation to a river, lake or wetland in Kenya, carry out any of the following activities—

- i. Erect, reconstruct, place, alter, extend, remove or demolish any structure or part of any structure in, or under the river, lake or wetland;
- ii. Excavate, drill, tunnel or disturb the river, lake or wetland;
- iii. Introduce any animal, whether alien or indigenous, dead or alive, in any river, lake or wetland;
- iv. Introduce or plant any part of a plant specimen, whether alien or indigenous, dead or alive, in any river, lake or wetland;
- v. Exposit any substance in a lake, river or wetland or in, on or under its bed, if that substance would or is likely to have adverse environmental effects on the river, lake or wetland;
- vi. Direct or block any river, lake or wetland from its natural and normal course; or
- vii. Drain any lake, river or wetland.

### **Occupational risks**

There are many jobs in industries which are highly prone to accidents. Coal-mining, marine transport, quarry and construction, chemical factories etc., are more dangerous as compared to communication, banking or IT industries.

### **Slipping, Tripping or Falling on the Floor:**

People fall when they slip. Highly polished surfaces, accumulation of water, soap or oil, on the floor, torn or loose coverings causes the floor to be slippery.

### **Collision and Obstruction:**

This takes place when there are inadequate lighting arrangements, furniture and equipments are placed improperly, sharp edges of machines etc.

### **Equipments and Machines:**

Heavy mechanical machines are not handled properly or maintenance is low. Defective equipment, improperly guarded equipment, overloading of machines, wiring of suitable is not proper. Safety devices have been removed, adjusted or disconnected.

### **Types of hazards**

#### **Electric shock**

Passage of current through the body of such magnitude as to have significant harmful effect.

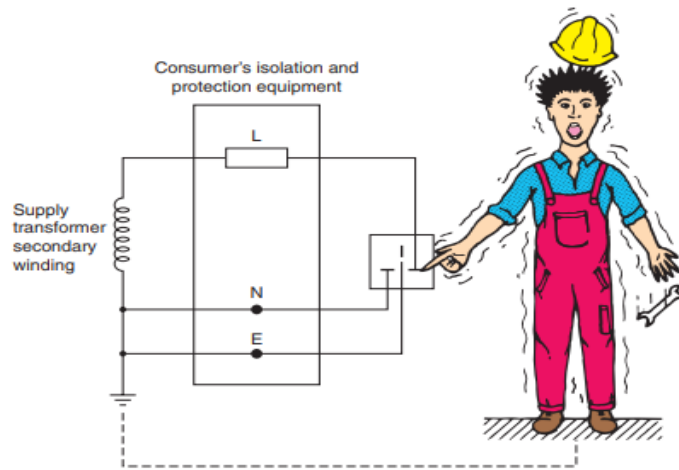

Figure 2: Demonstration of Electrical Shock

Touching live and earth or live and neutral makes a person part of the electrical circuit and can lead to an electric shock.

- i. Electric shock occurs when a person becomes part of the electrical circuit.
- ii. One gets electric shock when he or she is in contact with two objects that are at different potentials.
- iii. The person completes the circuit to earth and the current flows through him/or her.

### Electrical safety

- i. Electrical cannot be seen we only see the effect due to it.
- ii. Because of this care must be taken when using electricity. There are two main causes of accidents due to electricity.

These are:

- i. Carelessness: this arises because of laxity. When electricians have worked for long period, they tend to assume the high standards of safety required and start to maintain equipment when it's live and as a result an accident can easily occur.
- ii. Ignorance and inexperience. Most of the electrical tasks appear very simple when carried out by well-trained electricians. When unqualified personnel attempt to do the same they are usually unable and they leave the tasks uncompleted. This is dangerous to the others. The safety precaution in any electrical installation is to:
  - a) Prevent electric shock
  - b) Prevent the occurrence of fire due to electrical fires.

The damage done to the human body will depend on the following factors:

- i. Voltage between the two points
- ii. The amount of current flowing

iii. The time taken for the current to flow

Also, the level or intensity of the shock will depend upon factors, such as age, fitness and the circumstances in which the shock is received. The lethal level is approximately 50 mA, above which muscles contract, the heart flutters and breathing stops. A shock above the 50-mA level is therefore fatal unless the person is quickly separated from the supply. Below 50 mA only an unpleasant tingling sensation may be experienced or you may be thrown across a room, roof or ladder, but the resulting fall may lead to serious injury.

Two ways in which one can be at risk of electric shock

- i. Touching live parts of equipment or systems that are intended to be live.
- ii. Touching conductive parts which are not meant to be live, but have become live due to a fault.

### Shock levels

1mA - 2mA	Barely perceptible, no harmful effects
5mA - 10mA	Throw off, painful sensation
10mA - 15mA	Muscular contraction, can't let go
20mA - 30mA	Impaired breathing
50mA and above	Ventricular fibrillation and death

### Basic electrical protection against shock

- i. Insulate any live parts.
- ii. Ensure that any uninsulated live parts are housed in suitable enclosures and/or are behind barriers.
- iii. Place obstacles in the way. (This method would only be used in areas where skilled and/or authorized persons were involved.)
- iv. Placing live parts out of reach. (Once again, only used in special circumstances, e.g., live rails of overhead travelling cranes.)
- v. A residual current device (RCD) may be used as additional protection to any of the other measures taken, provided that it is rated at 30 mA or less and has an operating time of not more than 40ms at a test current of five times its operating current. It should be noted that RCDs are not the panacea for all electrical ills, they can malfunction, but they are a valid and effective backup to the other methods. They must not be used as the sole means of protection.

### The methods used to prevent electric shock are;

- i. Earthing the metallic and any equipment within the installation
- ii. Using all the insulated wiring systems

### Treatment of electric shock



If somebody get electric shock, the immediate action should be:

- i. Switch off the supply
- ii. If necessary, start artificial respiration
- iii. Seek medical assistance
- iv. Treat the burns or injuries.
- v. Keep the victim warm.

### **Fault protection**

Protection against shock from contact with unintentionally live, exposed or extraneous conductive parts whilst touching earth, or from contact between unintentionally live exposed and/ or extraneous conductive parts? The most common method is by protective earthing, protective equipotential bonding and automatic disconnection in case of a fault.

### **Use of class II equipment**

Double-insulated equipment, this is typical of modern appliances where there is no provision for the connection of a cpc. The casing of equipment should be of an insulating material; it simply indicates that live parts are so well insulated that faults from live to conductive parts cannot occur.

### **Non-conducting location**

Area in which the floor, walls and ceiling are all insulated. Within such an area there must be no protective conductors, and socket outlets will have no earthing connections.

It must not be possible simultaneously to touch two exposed conductive parts, or an exposed conductive part and an extraneous conductive part. This requirement clearly prevents shock current passing through a person in the event of an earth fault, and the insulated construction prevents shock current passing to earth.

### **Earth-free local equipotential bonding**

This is in essence a Faraday cage, where all metal is bonded together but not to earth. Obviously, great care must be taken when entering such a zone in order to avoid differences in potential between inside and outside.

The areas mentioned in this and the previous method are very uncommon. Where they do exist, they should be under constant supervision to ensure that no additions or alterations can lessen the protection intended.

### **Electrical separation**

This method relies on a supply from a safety source such as an isolating transformer to BS EN 61558-2-6 which has no earth connection on the secondary side. In the event of a circuit that is

supplied from a source developing a live fault to an exposed conductive part, there would be no path for shock current to flow

Once again, great care must be taken to maintain the integrity of this type of system, as an inadvertent connection to earth, or interconnection with other circuits, would render the protection useless.

### **Use of enclosures**

The use of enclosures is not limited to protection against shock from contact with live parts, they clearly provide protection against the ingress of foreign bodies and moisture. In order to establish to what degree an enclosure can resist such ingress, reference to the Index of Protection (IP) code (BS EN 60529) should be made.

### **Fire hazards:**

Non-existence of fire escapes and exits can cause serious injuries, especially factories manufacturing inflammable objects like crackers, papers, chemical etc. Fire protection equipment and fire extinguishers have not properly fitted or available in the factory.

### **Types of fires and fire fighting**

#### **Types of fires**

Fire can cause loss of lives, jobs equipment, materials and buildings.

For all practical purposes there are three main classes of fires; A B & C

#### **Class A fires.**

Fires in ordinary combustible materials such as wood, paper & cloth.

The majorities of fires are in this class and can be most effectively extinguished by cooling with **water.**

#### **Class-B fires**

Fires from flammable liquids such as paraffin, petrol, paint, varnishes, oil and from greases and fats. These are effectively extinguished by smattering foam or other agents which exclude oxygen.

#### **Class-C fires**

Fires involving live electrical equipment and wiring. The safest method of extinguishing is to displace the oxygen by projecting a gas or dry powder into the vicinity of the fire.

In the event of a fire:

The following precautions should be observed at all times.

- i. Know the correct fire drill and the positions of fire alarms, firefighting equipment and emergency exits.

- ii. Know the correct appliance to use for a particular type of fire and know how to use it.
- iii. Don't block fire exit.
- iv. Don't use fire appliances for any purpose other than intended.
  - v. Never smoke in no smoking areas
  - vi. Always ensure that matches and cigarettes are put out before throwing them away
  - vii. Avoid spillage of flammable liquids.

## Extinguishers and fighting procedures

### Water type

These are usually operated by striking a plunger to release a gas which pressures the water and forces it out of the nozzle. They are stable only for class-A fires.

The jet should be directed at the base of the fire and be kept moving across the area of the fire.

### Chemical foam type

- i. These may be operated by inverting the extinguisher or by releasing a plunger allowing two solutions to mix and produce foam.
- ii. They are used on class B fires involving flammable liquids.
- iii. The jet is directed with a gentle sweeping movement, allowing the foam to drop down and lie on the surface of the liquid.
- iv. This smothers the fire by excluding oxygen.

### Carbon-dioxide (CO<sub>2</sub>) type

These are operated by squeezing the discharge lever which allows the liquid CO<sub>2</sub> to be discharged as a gas. They are used on class C fires where after the current has been switched off the discharge horn is directed straight at the fire.

### Dry powder pressure type.

This type contains a pressurized gas and a dry chemical agent. After the release lever has been operated discharge is controlled by a nozzle at the end of the hose.

These are used on class C fires in the same way as the CO<sub>2</sub> type.

### Use of fire extinguishers

Class of fire		Type of fire extinguisher			
		Water	Foam	CO <sub>2</sub>	Dry powder
A	Ordinary fires: wood, paper, cloth	Yes	Yes	No	No
B	Flammable liquids: petrol, paraffin	No	Yes	Yes	Yes
C	Electrical equipment	No	No	Yes	Yes

Table 1: Use of Fire Extinguishers

## **Fire precautions**

Fire is a great danger in a workshop and care must be taken not to start a fire. The main causes of fire are:

- i. Careless storage of flammable materials.
- ii. Careless electrical maintenance.
- iii. People throwing away cigarettes.

## **First aid**

First aid is the initial assistance or treatment given to a casualty for any injury or sudden illness before the arrival of an ambulance, doctor or other medically qualified person.

A first aider is someone who has undergone a training course to administer first aid at work and holds a current first aid certificate.

An appointed person is someone who is nominated to take charge when someone is injured or becomes ill, including calling an ambulance if required. The appointed person will also look after the first aid equipment, including re-stocking the first aid box.

Despite all the safety precautions taken on construction sites to prevent injury to the workforce, accidents do happen and you may be the only other person able to take action to assist a workmate. If you are not a qualified first aider limit your help to obvious common-sense assistance and call for help, but do remember that if a workmate's heart or breathing has stopped as a result of an accident, he has only minutes to live unless you act quickly.

The Health and Safety (First Aid) Regulations 1981 and relevant approved codes of practice and guidance notes place a duty of care on all employers to provide adequate first aid facilities appropriate to the type of work being undertaken.

The regulations state that:

Employers are under a duty to provide such numbers of suitable persons as is adequate and appropriate in the circumstances for rendering first aid to his employees if they are injured or become ill at work.

For this purpose, a person shall not be suitable unless he or she has undergone such training and has such qualifications as the Health and Safety Executive may approve.

This is typical of the way in which the health and safety regulations are written. The regulations and codes of practice do not specify numbers, but set out guidelines in respect of the number of first aiders needed, dependent upon the type of company, the hazards present and the number of people employed.

First aid is the treatment of minor injuries which would otherwise receive no treatment or do not need treatment by a doctor or nurse or in cases where a person will require help from a doctor or nurse, first aid is treatment for the purpose of preserving life and minimizing the consequences of an injury or illness until such help is obtained. A more generally accepted definition of first aid might be as follows: first aid is the initial assistance or treatment given to a casualty for any injury or sudden illness before the arrival of an ambulance, doctor or other medically qualified person.

A first aider is someone who has undergone a training course to administer first aid at work and holds a current first aid certificate. The training course and certification must be approved by the HSE.

- i. The aims of a first aider are to preserve life, to limit the worsening of the injury or illness and to promote recovery.
- ii. A first aider may also undertake the duties of an appointed person. An appointed person is someone who is nominated to take charge when someone is injured or becomes ill, including calling an ambulance if required.
- iii. The appointed person will also look after the first aid equipment, including re-stocking the first aid box.
- iv. Appointed persons should not attempt to give first aid for which they have not been trained, but should limit their help to obvious common-sense assistance and summon professional assistance as required.
- v. First aid personnel must be available at all times when people are at work, taking into account shift working patterns and providing cover for sickness absences.

### **Bleeding**

If the wound is dirty, rinse it under clean running water. Clean the skin around the wound and apply a plaster, pulling the skin together.

If the bleeding is severe apply direct pressure to reduce the bleeding and raise the limb if possible. Apply a sterile dressing or pad and bandage firmly before obtaining professional advice.

To avoid possible contact with hepatitis or the AIDS virus, when dealing with open wounds, first aiders should avoid contact with fresh blood by wearing plastic or rubber protective gloves, or by allowing the casualty to apply pressure to the bleeding wound.

### **Burns**

Remove heat from the burn to relieve the pain by placing the injured part under clean cold water. Do not remove burnt clothing sticking to the skin. Do not apply lotions or ointments. Do

not break blisters or attempt to remove loose skin. Cover the injured area with a clean dry dressing.

### **Broken bones**

Make the casualty as comfortable as possible by supporting the broken limb either by hand or with padding. Do not move the casualty unless by remaining in that position he is likely to suffer further injury. Obtain professional help as soon as possible.

### **Contact with chemicals**

Wash the affected area very thoroughly with clean cold water. Remove any contaminated clothing. Cover the affected area with a clean sterile dressing and seek expert advice. It is a wise precaution to treat all chemical substances as possibly harmful; even commonly used substances can be dangerous if contamination is from concentrated solutions. When handling dangerous substances, it is also good practice to have a neutralizing agent to hand.

Disposal of dangerous substances must not be into the main drains since this can give rise to an environmental hazard, but should be undertaken in accordance with local authority regulations.

### **Exposure to toxic fumes**

Get the casualty into fresh air quickly and encourage deep breathing if conscious. Resuscitate if breathing has stopped. Obtain expert medical advice as fumes may cause irritation of the lungs.

### **Sprains and bruising**

A cold compress can help to relieve swelling and pain. Soak a towel or cloth in cold water, squeeze it out and place it on the injured part. Renew the compress every few minutes.

#### **Breathing stopped**

- i. Remove any restrictions from the face and any vomit, loose or false teeth from the mouth. Loosen tight clothing around the neck, chest and waist.
- ii. To ensure a good airway, lay the casualty on his back and support the shoulders on some padding.
- iii. Tilt the head backwards and open the mouth.
- iv. If the casualty is faintly breathing, lifting the tongue, clearing of the airway may be all that is necessary to restore normal breathing.
- v. However, if the casualty does not begin to breathe, open your mouth wide and take a deep breath, close the casualty's nose by pinching with your fingers, and, sealing your lips around his mouth, blow into his lungs until the chest rises.
- vi. Remove your mouth and watch the casualty's chest fall.
- vii. Continue this procedure at your natural breathing rate.
- viii. If the mouth is damaged or you have difficulty making a seal around the casualty's mouth, close his mouth and inflate the lungs through his nostrils.

- ix. Give artificial respiration until natural breathing is restored or until professional help arrives.

### **Heart stopped beating**

- i. This sometimes happens following a severe electric shock. If the casualty's lips are blue, the pupils of his eyes widely dilated and the pulse in his neck cannot be felt, then he may have gone into cardiac arrest.
- ii. Act quickly and lay the casualty on his back.
- iii. Kneel down beside him and place the heel of one hand in the Centre of his chest.
- iv. Cover this hand with your other hand and interlace the fingers.
- v. Straighten your arms and press down on his chest sharply with the heel of your hands and then release the pressure.
- vi. Continue to do this 15 times at the rate of one push per second.
- vii. Check the casualty's pulse. If none is felt, give two breaths of artificial respiration and then a further 15 chest compressions.
- viii. Continue this procedure until the heartbeat is restored and the artificial respiration until normal breathing returns. Pay close attention to the condition of the casualty while giving heart massage.
- ix. When a pulse is restored the blueness around the mouth will quickly go away and you should stop the heart massage. Look carefully at the rate of breathing. When this is also normal, stop giving artificial respiration.
- x. Treat the casualty for shock; place him in the recovery position and obtain professional help.

### **Shock**

Everyone suffers from shock following an accident. The severity of the shock depends upon the nature and extent of the injury. In cases of severe shock, the casualty will become pale and his skin become clammy from sweating. He may feel faint, have blurred vision, feel sick and complain of thirst. Reassure the casualty that everything that needs to be done is being done. Loosen tight clothing and keep him warm and dry until help arrives. Do not move him unnecessarily or give him anything to drink.

### **Some of the items that are found in a First-Aid Box**

- i. Pair of scissors
- ii. Large size sterilized dressings
- iii. Medium size sterilized dressings
- iv. Small sized sterilized dressings
- v. Large size burn dressings
- vi. Packets of sterilized cotton wool

- vii. Rolled bandages 10 cm wide
- viii. Rolled bandages 5 cm wide
- ix. Bottle (4 oz) of salvolative having the doze and made 1 of administration indicated on label
- x. Safety pins
- xi. Eye drops
- xii. Adhesive plaster
- xiii. 4 bottles containing KMnO<sub>4</sub> crystals, etc.
- xiv. 4 bottles containing a 2% alcoholic solution
- xv. Betadine ointment (50mg)
- xvi. Slaframine ointment (50mg)
- xvii. Dettol

### **Methods of resuscitation**

If the person is in contact with the live conductors then the first thing is to break the contact. care must be taken in order not electrocute yourself.

Try to switch off the supply or to unplug the equipment incase it's a portable tool e.g., a drill. Under no circumstances should you attempt to touch the person. It may be possible to detach the person by pulling or pushing him/her by using insulated object e.g. an insulated cable looped rounded the victims arm or body using a dry wooden pole.

After the victim is removed from the live contacts provide artificial respiration by using any of the following methods

- i. Mouth to mouth
- ii. Holger-Nelson

### **Mouth -mouth**

In this method, the patient must be on his back and his mouth should be inspected for any obstructions e.g., false teeth.

- i. The patient head should be extended by placing one hand on his crown and the other immediately beneath his chin.
- ii. Gently bend his head backwards and then using his both hands, lift his jaw forward.
- iii. Place your lips over the patients' mouth and make a good seal with the thumb and one fore finger of one hand gently close the patient nostrils.
- iv. Take a deep breath and exhale into the patient using little force.
- v. Watch and feel the patient's chest rise. Remove your lips and let the lungs deflate.
- vi. The above procedure should be repeated twelve times per minute remembering to turn away your head as you don't fill your own lungs with the patients expired air.



vii. Continue inflation and depletion of the lungs until spontaneous breathing is maintained.

### Holger and Neilson.

- i. The patient should be placed face downwards with the arm overhead, the elbows flexed so that one hand rests on the other in turn.
- ii. Turn the patients head to one side so that the neck rests on his upper most hand. Kneel to one side of the patients head and put the foot of your other leg near his elbow.
- iii. Place your hands on his back just below the shoulder blades and rock forwards with your elbow straight until your arms are approximately vertical, exerting- steady pressure on his chest.
- iv. Grasp the patient’s arms just above the elbow and rock backwards raising his arms until tension is felt at the patient’s shoulder lower his arms.
- v. The complete cycle should be repeated twelve times a minute.
- vi. This method is practical only when there’s no gross injury to the arms shoulder and the ribs.

### Learning activities

- i. Demonstrate donning of the PPEs and allow the trainee to practice.
- ii. Demonstrate firefighting techniques.
- iii. Demonstrate the resuscitation techniques using dummies.

Field/Visit to an established electrical workshop

Visit Objective/Aim	Indicators	Special Instruction
To establish the use of PPEs in a workshop	<ul style="list-style-type: none"> <li>• Technician fully in PPEs</li> </ul>	Take notes

Table 2: Visit to an Electrical Workshop

### Self-Assessment questions

1. What are classes of fire? (3 Marks)
2. How is Holger-Nelsons respiration method? (5Marks)
3. What items are found in the first aid box? (7Marks)

### Tools, Equipment and Materials

- PPE including working gloves, overalls/dustcoats, safety shoes, helmets, goggles, safety harness.
- Assorted firefighting equipment
- Copies of regulations

## REFERENCES

- Occupational Safety and Health Act
- Work Injury Benefits Act
- Environmental Management and Co-ordination Act
- Institute of Electrical Engineers regulations
- Electrical Installation by A.J Watkins . C. Kitcher
- Guidelines for Personal Protective Equipment (PPE)- University of Washington
- Basic First Aid Training and Procedures for emergency - Uncharted Supply Co.

1.

[www.inc.com](http://www.inc.com) › [encyclopedia](#) › [workplace-safety](#)

## Model answers to Self-Assessment Questions

### 1. Classes of fire (3 Marks)

- i. Class A
- ii. Class B
- iii. Class C
- iv. Class D
- v. Class E

### 2. Holger-Nelson's respiration method (5Marks)

- i. The patient should be placed face downwards with the arm overhead, the elbows flexed so that one hand rests on the other in turn.
- ii. Turn the patients head to one side so that the neck rests on his upper most hand. Kneel to one side of the patients' head and put the foot of your other leg near his elbow.
- iii. Place your hands on his back just below the shoulder blades and rock forwards with your elbow straight until your arms are approximately vertical, exerting- steady pressure on his chest.
- iv. Grasp the patient's arms just above the elbow and rock backwards raising his arms until tension is felt at the patient's shoulder lower his arms.
- v. The complete cycle should be repeated twelve times a minute.
- vi. This method is practical only when there's no gross injury to the arms shoulder and the ribs.

### 3. Items of a First-Aid Box (7Marks)

- i. Pair of scissors
- ii. Large size sterilized dressings
- iii. Medium size sterilized dressings
- iv. Small sized sterilized dressings
- v. Large size burn dressings

- vi. Packets of sterilized cotton wool
- vii. Packets of sterilized cotton wool
- viii. Rolled bandages 10 cm wide
- ix. Rolled bandages 5 cm wide
- x. Bottle (4 oz) of salvolatile having the doze and made 1 of administration indicated on label
- xi. Safety pins
- xii. Eye drops
- xiii. Adhesive plaster
- xiv. Dettol

easytvvet.com

## 1.1.Perform Basic Metal Works

### Introduction

This learning outcome specifies the content of competencies required on metal working, forming processes, cutting processes, joining processes and associated processes of basic metal works.

### Performance Standard

- i. Use of safety harness and PPE
- ii. Types of metals e.g., Mild steel, steel
- iii. Purpose of the metals
- iv. Application of metals

### Information Sheet.

#### Metalworking

Is the process of working with metals to create individual parts, assemblies, or large-scale structures. Metalworking generally is divided into three categories:

- i. Forming
- ii. Cutting,
- iii. Joining.

Most metal cutting is done by high-speed steel tools or carbide tools. Each of these categories contains various processes.

Prior to most operations, the metal must be marked out and/or measured, depending on the desired finished product.

**Marking out (also known as layout)** is the process of transferring a design or pattern to a work piece and is the first step in the handcraft of metalworking. It is performed in many industries or hobbies, although in industry, the repetition eliminates the need to mark out every individual piece. In the metal trades area, marking out consists of transferring the engineer's plan to the workpiece in preparation for the next step, machining or manufacture.



Figure 3: Combination Square used for transferring design

Calipers are hand tools designed to precisely measure the distance between two points. Most calipers have two sets of flat, parallel edges used for inner or outer diameter measurements. These calipers can be accurate to within one-thousandth of an inch (25.4  $\mu\text{m}$ ). Different types of calipers have different mechanisms for displaying the distance measured. Where larger objects need to be measured with less precision, a tape measure is often used.



Figure 4: A Caliper for Measuring Length

### Compatibility chart of materials versus processes

Process	Material										
	Iron	Steel	Aluminum	Copper	Magnesium	Nickel	Refractory metals	Titanium	Zinc	Brass	Bronze
Sand casting	X	X	X	X	X	X			0	0	X
Permanent mold casting	X	0	X	0	X	0			0	0	X
Die casting			X	0	X				X		

Investment casting		X	X	X	0	0				0	X
Ablation casting		X	X	X	0	0					
Open-die forging		0	X	X	X	0	0	0			
Closed-die forging		X	0	0	0	0	0	0			
Extrusion		0	X	X	X	0	0	0			
Cold heading		X	X	X		0					
Stamping & deep drawing		X	X	X	0	X		0	0		
Screw machine	0	X	X	X	0	X	0	0	0	X	X
Powder metallurgy	X	X	0	X		0	X	0			
Key: X = Routinely performed, 0 = Performed with difficulty, caution, or some sacrifice, blank = Not recommended											

Table 3: Compatibility Chart of Material versus Processes

### Metal casting

Casting achieves a specific form by pouring molten metal into a mold and allowing it to cool, with no mechanical force. Forms of casting include:

- i. Investment casting (called lost wax casting in art)
- ii. Centrifugal casting
- iii. Die casting

- iv. Sand casting
- v. Shell casting
- vi. Spin casting

### A Sand-casting mold



Figure 5: A Sand- Casting Mold

These forming processes modify metal or workpiece by deforming the object, that is, without removing any material. Forming is done with a system of mechanical forces and, especially for bulk metal forming, with heat

### Bulk forming processes



A red-hot metal workpiece is inserted into a forging press.

Plastic deformation involves using heat or pressure to make a work piece more conductive to mechanical force. Historically, this and casting were done by blacksmiths, though today the process has been industrialized. In bulk metal forming, the work piece is generally heated up.

- i. Cold sizing
- ii. Extrusion
- iii. Drawing
- iv. Forging
- v. Powder metallurgy
- vi. Friction drilling
- vii. Rolling
- viii. Burnishing

easyvet.com

### **Sheet metal**

These types of forming process involve the application of mechanical force at room temperature. However, some recent developments involve the heating of dies and/or parts. Advancements in automated metalworking technology have made progressive die stamping possible which is a method that can encompass punching, coining, bending and several other ways below that modify metal at less cost while resulting in less scrap.

- i. Bending
- ii. Coining
- iii. DE cambering
- iv. Deep drawing (DD)
- v. Flow forming
- vi. Hydroforming (HF)



- vii. Hot metal gas forming
- viii. Hot press hardening
- ix. Incremental forming (IF)
- x. Spinning, Shear forming or Flow forming



Figure 6: A Metal Spun brass vase

- xi. Raising
- xii. Roll forming
- xiii. Roll bending
- xiv. Repoussé and chasing
- xv. Rubber pad forming
- xvi. Shearing
- xvii. Stamping
- xviii. Superplastic forming (SPF)
- xix. Wheeling using an English wheel (wheeling machine)

### Cutting Process



Figure 7: A CNC Plasma Cutting Machine

## Cutting

Cutting is a collection of processes wherein material is brought to a specified geometry by removing excess material using various kinds of tooling to leave a finished part that meets specifications. The net result of cutting is two products, the waste or excess material, and the finished part. In woodworking, the waste would be sawdust and excess wood. In cutting metals, the waste is chips or swarf and excess metal.

**Cutting processes fall into one of three major categories:**

- Chip producing processes most commonly known as machining
- Burning, a set of processes wherein the metal is cut by oxidizing a kerf to separate pieces of metal
- Miscellaneous specialty process, not falling easily into either of the above categories

Drilling a hole in a metal part is the most common example of a chip producing process. Using an oxy-fuel cutting torch to separate a plate of steel into smaller pieces is an example of burning. Chemical milling is an example of a specialty process that removes excess material by the use of etching chemicals and masking chemicals.

There are many technologies available to cut metal, including:

- i. Manual technologies: saw, chisel, shear or snips
- ii. Machine technologies: turning, milling, drilling, grinding, sawing
- iii. Welding/burning technologies: burning by laser, oxy-fuel burning, and plasma
- iv. Erosion technologies: by water jet, electric discharge, or abrasive flow machining.
- v. Chemical technologies: Photochemical machining

Cutting fluid or coolant is used where there is significant friction and heat at the cutting interface between a cutter such as a drill or an end mill and the workpiece. Coolant is generally introduced by a spray across the face of the tool and workpiece to decrease friction and temperature at the cutting tool/workpiece interface to prevent excessive tool wear. In practice there are many methods of delivering coolant.

## Milling



**Figure 8: A Milling Machine in Operation, including Coolant Hoses**

### Milling (machining)

Milling is the complex shaping of metal or other materials by removing material to form the final shape. It is generally done on a milling machine, a power-driven machine that in its basic form consists of a milling cutter that rotates about the spindle axis (like a drill), and a worktable that can move in multiple directions (usually two dimensions [x and y axis] relative to the workpiece).

The spindle usually moves in the z axis. It is possible to raise the table (where the workpiece rests). Milling machines may be operated manually or under computer numerical control (CNC), and can perform a vast number of complex operations, such as slot

cutting, planing, drilling and threading, rabbeting, routing, etc. Two common types of mills are the horizontal mill and vertical mill.

The pieces produced are usually complex 3D objects that are converted into x, y, and z coordinates that are then fed into the CNC machine and allow it to complete the tasks required. The milling machine can produce most parts in 3D, but some require the objects to be rotated around the x, y, or z coordinate axis (depending on the need). Tolerances come in a variety of standards, depending on the locale. In countries still using the imperial system, this is usually in the thousandths of an inch (unit known as thou), depending on the specific machine. In many other European countries, standards following the ISO are used instead.

In order to keep the bit and material cool, a high temperature coolant is used. In most cases the coolant is sprayed from a hose directly onto the bit and material. This coolant can either be machine or user controlled, depending on the machine.

Materials that can be milled range from aluminum to stainless steel and almost everything in between. Each material requires a different speed on the milling tool and varies in the amount of material that can be removed in one pass of the tool. Harder materials are usually milled at slower speeds with small amounts of material removed. Softer materials vary, but usually are milled with a high bit speed.

The use of a milling machine adds costs that are factored into the manufacturing process. Each time the machine is used coolant is also used, which must be periodically added in order to prevent breaking bits. A milling bit must also be changed as needed in order to prevent damage to the material. Time is the biggest factor for costs. Complex parts can require hours to complete, while very simple parts take only minutes. This in turn varies the production time as well, as each part will require different amounts of time.

Safety is key with these machines. The bits are traveling at high speeds and removing pieces of usually scalding hot metal. The advantage of having a CNC milling machine is that it protects the machine operator.

## Turning



Figure 9: A Lathe Cutting Material from a Workpiece

## Turning

Turning is a metal cutting process for producing a cylindrical surface with a single point tool. The workpiece is rotated on a spindle and the cutting tool is fed into it radially, axially or both. Producing surfaces perpendicular to the workpiece axis is called facing. Producing surfaces using both radial and axial feeds is called profiling.

A lathe is a machine tool which spins a block or cylinder of material so that when abrasive, cutting, or deformation tools are applied to the workpiece, it can be shaped to produce an object which has rotational symmetry about an axis of rotation. Examples of objects that can be produced on a lathe include candlestick holders, crankshafts, camshafts, and bearing mounts.

Lathes have four main components: the bed, the headstock, the carriage, and the tailstock. The bed is a precise & very strong base which all of the other components rest upon for alignment. The headstock's spindle secures the workpiece with a chuck, whose jaws (usually three or four) are tightened around the piece. The spindle rotates at high speed, providing the energy to cut the material. While historically lathes were powered by belts from a line shaft, modern examples use electric motors.

The workpiece extends out of the spindle along the axis of rotation above the flat bed. The carriage is a platform that can be moved, precisely and independently parallel and perpendicular to the axis of rotation. A hardened cutting tool is held at the desired height (usually the middle of the workpiece) by the tool post. The carriage is then moved around the rotating workpiece, and the cutting tool gradually removes material from the workpiece. The tailstock can be slid along the axis of rotation and then locked in place as necessary. It may hold centers to further secure the workpiece, or cutting tools driven into the end of the workpiece.

**Other operations that can be performed with a single point tool on a lathe are:**

**Chamfering** : Cutting an angle on the corner of a cylinder.

**Parting** : The tool is fed radially into the workpiece to cut off the end of a part.

**Threading** : A tool is fed along and across the outside or inside surface of rotating parts to produce external or internal threads.

**Boring** : A single-point tool is fed linearly and parallel to the axis of rotation to create a round hole.

**Drilling** : Feeding the drill into the workpiece axially.

**Knurling** : Uses a tool to produce a rough surface texture on the work piece. Frequently used to allow grip by hand on a metal part.

Modern computer numerical control (CNC) lathes and (CNC) machining centres can do secondary operations like milling by using driven tools. When driven tools are used the work piece stops rotating and the driven tool executes the machining operation with a rotating cutting tool. The CNC machines use x, y, and z coordinates in order to control the turning tools and produce the product. Most modern-day CNC lathes are able to produce most turned objects in 3D.

Nearly all types of metal can be turned, although more time & specialist cutting tools are needed for harder workpieces.

**Threading**



Figure 10: Three Different Types and Sized of Taps

**Threading (manufacturing)**

**There are many threading processes including:**

- i. Cutting threads with a tap or die,
- ii. Thread milling,
- iii. Single-point thread cutting,
- iv. Thread rolling,
- v. Cold chisel rolling and forming,
- vi. thread grinding.

A tap is used to cut a female thread on the inside surface of a pre-drilled hole, while a die cuts a male thread on a preformed cylindrical rod

## Grinding



Figure 11: Grinding

Grinding uses an abrasive process to remove material from the workpiece. A grinding machine is a machine tool used for producing very fine finishes, making very light cuts, or high precision forms using an abrasive wheel as the cutting device. This wheel can be made up of various sizes and types of stones, diamonds or inorganic materials.

The simplest grinder is a bench grinder or a hand-held angle grinder, for deburring parts or cutting metal with a zip-disc.

Grinders have increased in size and complexity with advances in time and technology. From the old days of a manual toolroom grinder sharpening endmills for a production shop, to today's 30000 RPM CNC auto-loading manufacturing cell producing jet turbines, grinding processes vary greatly.

Grinders need to be very rigid machines to produce the required finish. Some grinders are even used to produce glass scales for positioning CNC machine axis. The common rule is the machines used to produce scales be 10 times more accurate than the machines the parts are produced for.

In the past grinders were used for finishing operations only because of limitations of tooling. Modern grinding wheel materials and the use of industrial diamonds or other man-made coatings (cubic boron nitride) on wheel forms have allowed grinders to achieve excellent results in production environments instead of being relegated to the back of the shop.

Modern technology has advanced grinding operations to include CNC controls, high material removal rates with high precision, lending itself well to aerospace applications and high-volume production runs of precision components.

## **Filing**

### **Filing (metalworking)**



Figure 12: Filing

A file is an abrasive surface like this one that allows machinists to remove small, imprecise amounts of metal.

**Filing** is combination of grinding and saw tooth cutting using a file. Prior to the development of modern machining equipment, it provided a relatively accurate means for the production of small parts, especially those with flat surfaces. The skilled use of a file allowed a machinist to work to fine tolerances and was the hallmark of the craft. Files can vary in shape, coarseness, and whether the teeth or single cut or double cut depending on what application the file is to be used for. Today filing is rarely used as a production technique in industry, though it remains as a common method of deburring.



## Joining process



Figure 13: Mig Welding

## Welding

**Welding** is a fabrication process that joins materials, usually metals or thermoplastics, by causing coalescence. This is often done by melting the workpieces and adding a filler material to form a pool of molten material that cools to become a strong joint, but sometimes pressure is used in conjunction with heat, or by itself, to produce the weld.

Many different energy sources can be used for welding, including a gas flame, an electric arc, a laser, an electron beam, friction, and ultrasound. While often an industrial process, welding can be done in many different environments, including open air, underwater and in space.

Regardless of location, however, welding remains dangerous, and precautions must be taken to avoid burns, electric shock, poisonous fumes, and overexposure to ultraviolet light.

### b) Brazing

**Brazing** is a joining process in which a filler metal is melted and drawn into a capillary formed by the assembly of two or more work pieces. The filler metal reacts metallurgically with the workpiece(s) and solidifies in the capillary, forming a strong joint. Unlike welding, the work piece is not melted. Brazing is similar to soldering, but occurs at temperatures in excess of 450 °C (842 °F).

Brazing has the advantage of producing fewer thermal stresses than welding, and brazed assemblies tend to be more ductile than weldments because alloying elements cannot segregate and precipitate.

Brazing techniques include, flame brazing, resistance brazing, furnace brazing, diffusion brazing, inductive brazing and vacuum brazing.

### **Soldering**



Figure 14: Soldering a Printed Circuit Board

Soldering is a joining process that occurs at temperatures below 450 °C (842 °F). It is similar to brazing in the way that a filler is melted and drawn into a capillary to form a joint, although at a lower temperature. Because of this lower temperature and different alloys used as fillers, the metallurgical reaction between filler and work piece is minimal, resulting in a weaker joint.

### **Riveting**

Riveting is one of the most ancient metalwork joining processes. It retains important uses in industry and construction, and in artisan crafts such as jewelry, medieval armouring and metal

couture . The earlier use of rivets is being superseded by improvements in welding and component fabrication techniques.

A rivet is essentially a two-headed and unthreaded bolt which holds two other pieces of metal together. Holes are drilled or punched through the two pieces of metal to be joined. The holes being aligned, a rivet is passed through the holes and permanent heads are formed onto the ends of the rivet utilizing hammers and forming dies (by either cold working or hotworking). Rivets are commonly purchased with one head already formed.

When it is necessary to remove rivets, one of the rivet's heads is sheared off with a cold chisel. The rivet is then driven out with a hammer and punch.

### **Associated processes**

While these processes are not primary metalworking processes, they are often performed before or after metalworking processes.

### **Heat treatment**

Metals can be heat treated to alter the properties of strength, ductility, toughness, hardness or resistance to corrosion. Common heat treatment processes include annealing, precipitation hardening, quenching, and tempering. The annealing process softens the metal by allowing recovery of cold work and grain growth. Quenching can be used to harden alloy steels, or in precipitation hardenable alloys, to trap dissolved solute atoms in solution. Tempering will cause the dissolved alloying elements to precipitate, or in the case of quenched steels, improve impact strength and ductile properties.

Often, mechanical and thermal treatments are combined in what is known as thermo-mechanical treatments for better properties and more efficient processing of materials. These processes are common to high alloy special steels, super alloys and titanium alloys.

### **Plating**

Electroplating is a common surface-treatment technique. It involves bonding a thin layer of another metal such as gold, silver, chromium or zinc to the surface of the product by hydrolysis. It is used to reduce corrosion, create abrasion resistance and improve the product's aesthetic appearance. Plating can even change the properties of the original part including conductivity, heat dissipation or structural integrity. There are four main electroplating methods to ensure proper coating and cost effectiveness per product: mass plating, rack plating, continuous plating and line plating.

### **Thermal spraying**

Thermal spraying techniques are another popular finishing option, and often have better high temperature properties than electroplated coatings due to the thicker coating. The four main

thermal spray processes include electric wire arc spray, flame (oxy acetylene combustion) spray, plasma spray and high velocity oxy fuel (HVOF) spray.

### **Learning Activities**

A **corded drill** is the only real power tool that we will be using in this class. While cordless drills get all the fanfare, corded drills give you the most bang for your buck - particularly for metalworking. You don't need to be particularly portable in the shop, and corded drills never run low on power. They also have a lot of torque, which is useful for metalworking. While they typically don't have all the fancy settings you may find on a cordless drill, these drills basically do one thing and they do it very well.

For this course you will only need a **7/64" drill bit**. That said, you may as well invest in a **basic drill bit set**. This is just generally useful for metalworking. We will be discussing drill bits more in the drilling lesson.

Another thing you will need is a **6-32 tap**, and a **tap handle wrench**. This is used to thread drilled holes. We will be discussing this much more in the fastener lesson.

If it is solid, you can likely cut through it with a hacksaw. A hacksaw can cut through just about anything, it just may take a while. In this course, we will be cutting metal using a hacksaw. Aside from learning about how metal cuts in a hands-on manner, it should give you a healthy appreciation for power saws.

A **table vise** is a handy tool when holding parts by hand won't cut it. For this course, a small vise that clamps onto the table will do (pictured). If you get deeper into metalworking, you will want to get one more heavy duty (preferably with a built-in anvil) that bolts onto your workbench.

For more delicate shaping operations, a hand file set is much more useful than a hacksaw. Files come in a range of shapes, and sizes. They also have a range of cutting teeth arrangements to provide finer or rougher cuts in the metal. You may notice that my files here are all bastards. This does not mean they were forged out of wedlock, but have 30 teeth per inch (TPI). This is about an average tooth count, and good for general purpose use. There are countless configurations of files available for just about every imaginable purpose. Files are one of the most fundamental tools of metalworking, and are used in almost every aspect of metalworking for shaping and finishing parts. While filing metal may seem like a simple activity, it can take a lifetime to truly master.

When you saw and drill metal, you leave behind sharp raised uneven edges called burrs. The **deburring tool** is designed to remove them. By dragging along the edge of the cut surface,

the burr is simply scraped away. This leaves behind a nice smooth beveled edge in its place. We will go over this more in a bit.

When metalworking, you will want a hammer. If you have a standard **claw hammer** at home already, that will be fine for now. However, for metalworking you will eventually want to invest in a **ball peen hammer** and a **dead blow** (both pictured above). A ball peen hammer has a striking surface on one side, and a ball on the other for shaping metal. This is much more useful than a generic claw hammer, since you will unlikely have any nails that will need removing. In addition, a dead blow has a counterweight inside of the striking head that minimizes rebound and translates most of the force downwards onto the surface being struck. This is useful for shaping metal (amongst other things).

**Center punches** are used to mark the center of the hole you are trying to drill. When used correctly, they leave behind a small dimple that will keep your drill bit in place and prevent it from wandering. You shouldn't consider drilling metal without first center punching it.

A **scribe** is used to leave a really light scratch on the surface of a metal part. This is used for marking cut and drill lines. This is preferably to pencil or marker because a scratch line is thinner, more accurate, and does not wear off easily.

If you are going to making scribe lines on your metal, you are likely going to need to do some measuring. It is recommended you get **digital calipers** and a **metal ruler**. You have likely used a ruler before, but may have not use calipers. So, to explain, digital calipers have two jaws which slide back and forth upon a track. On the readout, it tells you the distance between the two jaws to a fraction of an inch. This is useful for making really precise measurements, which you often need to do for metal. Unlike softer materials such as wood or plastic, metal has no give. You need to be spot-on with your measurements.

For this course you will want to get wet/dry **sandpaper** in a variety of sizes from 220 up to 2000. This is a little different than normal dry sandpaper used for woodworking. The most important part, is that the paper is stronger and doesn't rip as easily. We will be discussing sanding much more in the finishing section.

The **buffing wheels** we will be using in this class are shank-mounted and designed to go into a drill bit. They are basically a bunch of thin layers of fabric sandwiched together. It is the edge of the sandwiched fabric disc that is used to buff metal. This is yet another thing we will discuss more later.

If you are using a buffing wheel, you will want to get some metal-appropriate **buffing compound**. There are many different types of buffing compounds. Essentially, they act upon the

surface of the metal much in the same way a fine sandpaper does. This is a finishing touch used to create a smooth, shiny, surface upon metal.

### **Self-Assessment**

1. Which is not a safety practices in metal works?
  - A. Any person handling sheet metal fabrication tools should be equipped with safety gear.
  - B. They should wear hard hats, goggles, gloves, and safety shoes at all times.
  - C. Make sure that when working or handling any product, your back and neck are supported adequately.
  - D. Eating in the workshop.
2. Which metal is not used for metal work?
  - A. Copper
  - B. Iron,
  - C. wood
  - D. Bronze
3. What are the processes in metal works technology?
  - A. Forming
  - B. Cutting
  - C. Joining.
  - D. Casting
4. What is the easiest metal to work with?
  - A. Welding metals
  - B. Low carbon steel
  - C. Cast iron.
  - D. Silicon

### **Tools, Equipment and Materials**

- i. Hacksaw
- ii. Table vise
- iii. Hand file set
- iv. Deburring tool
- v. Corded drill
- vi. 36 and 6-32 drill and tap set
- vii. Center punch set
- viii. 16 oz. ball peen hammer
- ix. Steel ruler
- x. Calipers
- xi. Scribe
- xii. Adjustable tap handle
- xiii. Assorted sandpaper pack

- xiv. 4" buffing wheels
- xv. Surface Scratch Remover Buffing Compound

## References

- i. Goldman, Handbook of Modern Ferromagnetic Materials, Boston: Springer Science & Media, 1999
- ii. T. Ros-Yanez, Y. Houbaert, O. Fischer, J. Schneider, "Production of high silicon steel for electrical applications by thermomechanical processing," Journal of Materials Processing Technology, vol. 143-144, Dec., pp. 916-921, 2003.
- iii. "Electrical steel," TATASTEEL, n.d. [Online]  
Available: <https://www.tatasteeleurope.com/en/products/engineering/electrical-steel>
- iv. Raabe, "Electrical steels - Iron-Silicon Transformer Steels," n.d. [Online].  
Available: <http://www.dierk-raabe.com/electrical-steels-fe-3-si/> [Accessed Aug. 29, 2019]
- v. V. L. Bemmer, "The Properties of Electrical Steels and Their Coatings," PhD Thesis, Cardiff University, Cardiff, Wales, 2013.

## Model answers for Self -Assessment

- 1. D
- 2. C
- 3. D
- 4. A

easyvet.com

## 1.2. Install PVC Sheathed cable

### Introduction

In this context, by the end of the lesson the learner should learn about PVC cables, PPEs, learn about meaning of PVC sheathed cables, types and wiring methods.

### Performance standard

- i. Meaning of PVC sheathed cables
- ii. Types of sheathed cables
- iii. PVC sheathed cables wiring methods
- iv. Applications of sheathed cables

### Information Sheet

#### PVC sheathed cable

PVC is considered one of the most versatile among the thermoplastic materials. Used as a base material to cover the surface of electric cables, it is particularly suitable for the construction of electrical energy systems made up of rigid cables, long lasting and resistant to any type of

temperature. The cables with PVC covering are therefore ideal for outdoor use and are specially designed to give the installer the opportunity to realize both the installation and the raceways.

A thermoplastic-sheathed cable (TPS) consists of a toughened outer sheath of polyvinyl chloride (PVC) thermoplastic, covering one or more individual annealed copper conductors, themselves insulated with PVC. This type of wiring is commonly used for residential and light commercial construction in many countries.

Cables with PVC covers or insulation are:

Flame retardants resistant to various chemicals, including oils, acids and alkalis.

Given their lightness, PVC covers must be used with full knowledge and located in areas not subject to excessive impact or pressure. Furthermore, since the PVC coverings do not guarantee a great resistance to heat, it is advisable not to use them in areas exposed to high temperatures.

### **When to use PVC cables**

One of the main problems that may arise while using electric wires is the short circuit, responsible for fires and propagation of free flames very dangerous for the general safety.

Given the composition of the protections, the cables in PPE or PE are particularly resistant to fire and indicated to ensure therefore higher levels of protection against possible propagation of flames and fire in the event of a short circuit.

In order to be able to use PPE cables in the most congenial way, it is necessary to keep in mind the European legislation, in order to create an adequate compromise on the use of practical, functional and at the same time safe power cables.

For this reason, the main European legislation systems have immediately issued laws designed to guarantee users and installers the maximum degree of safety in the construction of power plants.

The objective of the regulations is to verify, through practical tests, that:

- i. During the arrangement the cables cannot harm the installer;
- ii. The cables resist heat and do not feed any flames;



- iii. In the event of a short circuit, do not cause flames;
- iv. Possible splashes of water do not trigger a short circuit;
- v. The quality of the cable guarantees an optimal yield.

### **The IEC 60331-11 standard**

There are some main protocols, issued specifically to verify the resistance of electric cables at particularly high temperatures. One of these is the international IEC 60331-11 protocol, which provides for the exposure of cables (of standard length) to a flame having a temperature of up to 750 degrees Celsius, for at least an hour and a half.

Other tests are carried out in a similar manner and are dedicated to safeguarding the safety of the installer and the end user, who is primarily responsible for the use of the power plant.

easytvvet.com

## Types of Sheathed Cables

Cable types may be grouped according to:

- i. **Conductor used:** - according to the conducting material used i.e., cables made of copper, aluminum etc.
- ii. **According to the number of cores:** bases on the number of cores a cable consists of, the cables may be divided into classes known as single core cables; twin core cables; three core cables.
- iii. **According to the voltage grading,** the cables may be divided into (I) 250/440-volt cables and (II) 650/1,100-volt cables.
- iv. **According to the type of insulation used:** these types of cables may be categorized as;
  - a) Vulcanized Indian – Rubber (VIR) insulated cables.
  - b) Tough rubber sheathed (TRS) or cab tyre sheathed (CTS) cables.
  - c) Polyvinyl Chloride cables (PVC)
  - d) Lead sheath cables
  - e) Weather proof cables
  - f) Flexible cords and cable

## Advantages & Disadvantages of Different Sheathed cables

- i. **Plastic insulated cables.** It has the advantage of good insulation performance, the manufacturing process is simple, the price is low, regardless of the application or pipe can replace the rubber insulation, thus saving a lot of rubber and cotton yarn.

The disadvantage is poor performance to adapt to the climate, low temperature when the hard brittle, high temperature or sunlight under the plasticizer is easy to volatilize insulation aging accelerated. Therefore, in the absence of effective insulation measures in the high temperature environment, daylight exposure or cold places should choose the appropriate special type of plastic cable.

- ii. **Neoprene insulated cable.** Increasing weight, 35mm<sup>2</sup> below the ordinary rubber line has been replaced by chloroprene rubber insulated cable trend. It is characterized by good oil resistance, not easy mold, no flame, to adapt to climate performance, light aging process is slow, aging time is about two times the ordinary rubber insulated cable, so suitable for outdoor laying. Since the mechanical strength of the insulating layer is weaker than that of ordinary rubber, it is not recommended for pipe laying.
- iii. **Overhead insulated cable,** the use of increasingly wide, it is better resistance to light aging performance, mainly for high groundwater level, excellent place to deal with corrosion of liquid overflow, two plant outside the cable number of small and inconvenient buried underground, the Cable is suitable for urban distribution cable reconstruction.

- iv. **viscous impregnated low insulation power cable**, its advantages allow high operating temperature, low dielectric loss, high voltage strength, long life, the shortcomings of poor insulation properties of insulating materials cannot be laid at low temperatures, or easy to damage insulation.
- v. **PVC insulated and sheathed power cable** (referred to as plastic cable), 1KV and 6KV poles, the main advantage is the manufacturing process is simple, no laying height difference, light weight, bending performance, Simple, resistant to acid and alkali corrosion, no flame, with internal armor structure, so that steel or steel wire from corrosion, cheap.
- vi. **Rubber insulated power cable**. Its bending performance is better, can be laid in the cold climate, especially for the laying of line height difference and vertical laying occasions. It is not only suitable for fixed laying lines, but also for fixed movement of fixed laying lines. Mobile electrical equipment, power supply circuit should be used rubber insulated rubber sheathed flexible cable (referred to as rubber flexible cable)
- vii. **Metal sheathed mineral insulated cables**. High temperature, high temperature, 1000 °C) and the following high temperature, high humidity, high temperature, high temperature, high temperature, high temperature, high temperature, , Flammable, explosive environment. Its long-term working environment temperature up to 250°C ~ 400°C, is the ideal high temperature cable.

## PILC Solid Type Copper

Single or Three Conductors



Figure 15: Parts of PILC Cables

- i. **Copper Conductor**: Annealed bare copper conductor, normal, compact round, or compact sectoral stranded, per ASTM B3, B8, B496.

- ii. **Conductor Shield:** Carbon black impregnated semiconducting paper tapes adjacent to and in contact with the conductor.
- iii. **Insulation:** Paper, 100% high quality sulphate – processed wood pulp paper tapes helically and uniformly applied around the conductor.
- iv. **Insulation Shielding:** For 10 kV rated cables and up, semiconducting carbon black paper tapes over the insulation in single conductor cable. In shielded multiple conductor cable, copper tapes intercalated with carbon black semi-conducting paper tapes over individual insulation. Belted multi-conductor shielded cables shall have a shielding consisting of carbon black semiconducting paper tapes.

Assembly (Multi-conductor cables): Individual insulated conductors are cabled with paper fillers in interstices to give around core, and a binder paper tape.

- v. **Binder:** For shielded multi-conductor cables an optional binder of semi-conducting tapes (20 mil maximum), paper tapes (20 mil maximum) or copper tapes intercalated with paper tapes. Impregnate: High viscosity impregnating oil, applied after an appropriate vacuum drying process.
- vi. **Sheath:** Commercially pure lead sheath. Some other lead alloys available on request.
- vii. **Jacket:** Extruded thermoplastic polyethylene. Optional polyvinyl chloride (PVC) jacket.

#### **Advantages:**

PILC cables are hermetically sealed with a lead sheath, which protect the cables against humidity, gasoline and most chemical agents.

Outer jacket provides additional protection against corrosion and galvanic action.

#### **Application**

PILC cables are used in power distribution and other industrial circuits, where it is necessary to splice into existing PILC cable system.

#### **Reasons Why PVC Cables Are Widely Used for Internal Wiring**

- i. PVC insulation provides better flexibility for the cables
- ii. PVC insulation has better insulating qualities
- iii. PVC insulation is not highly affected by chemicals
- iv. PVC insulation has thin layer which will give smaller diameter of cables which makes it possible to accommodate more wires in the conduit of a given size unlike VIR or CTS wires

## Flexible cables

Flexible cables are cables containing one or more cores each formed of a group of wires, the diameter of cores and of the wires being very small in order to give it flexibility.

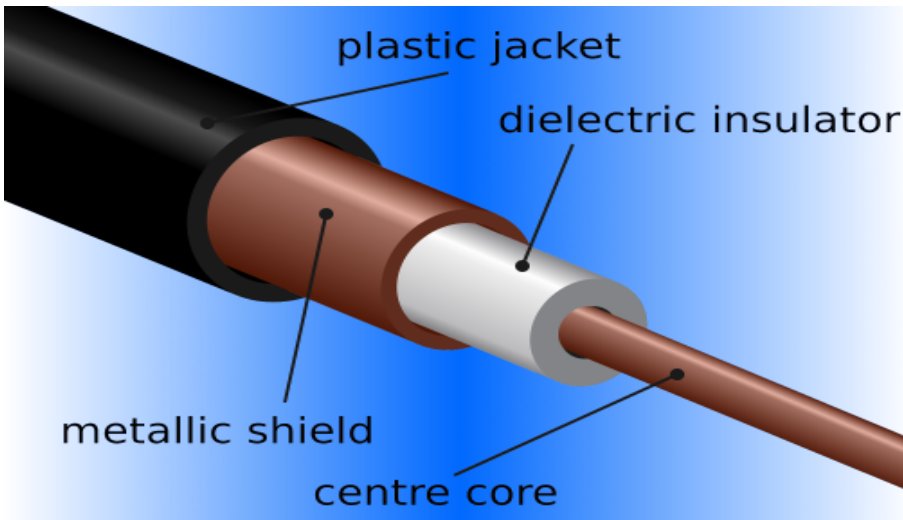

Figure 16: Flexible Cable

These cables are used as connecting wires for portable apparatus such as radios, fans and lamp holders etc. The flexibility of the cable prevents it from easy breakage.

## PVC sheathed cables wiring methods

### Electrical wiring system (methods)

It is a network of wires connecting various accessories for distribution of electrical energy from the supplier meter board to devices that consumes the energy such as televisions, refrigerators, fans, lamps etc.

### Choice of Wiring Systems

Before wiring start, right choice of wiring should be made basing on technical and economic factors.

Factors to be considered when making choice for a particular system of wiring;

- i. Cost of wiring: - The initial cost of the wiring system to be chosen or selected should be economical.
- ii. Durability: - wiring type should be durable (long lasting) and should also be of proper specifications and in accordance with assessed life and type of building to be wired.

- iii. **Permanency:** The wiring should not deteriorate by the action of weather, fumes, dampness etc. the cables should be resistant to harsh weather and chemical attacks.
- iv. **Accessibility:** Facilities used in the wiring should be available (within range) and accessible when the need for alteration, extension or renewal arises.
- v. **Appearance:** The wiring should provide a good look after its installation.
- vi. **Mechanical Protection:** The wiring should be protected from mechanical damage during its use.
- vii. **Safety:** When it comes to wiring, safety is paramount factors to be considered because electrocution is one thing you won't have the time to give it a second thought. Where there is possibility of fire hazard, conduit wiring should be used.
- viii. **Maintenance Cost:** Wiring system employed should have low maintenance cost.
- ix. **Load:** The types of loads consuming the electrical energy in a building will determine the kinds of cables to be used. You cannot use a cable with small diameter for heavy loads (high current) as cables will be damaged. Voltage to be employed and fire hazard and insurance standards should also be kept in mind in case of large factories

### **Types of Electrical Wiring Systems and installation used in Internal Wiring**

#### **PVC sheath Wiring (CTS or TRS)**

Is in form of single core or double core or three core circular oval shape cables.

TRS cables are chemical, water, steam proof, but are slightly affected by lubricating oil.

They are run on wood batten with at least a thickness of 10mm.

They are held on the wooden batten by means of tinned brass link clips (buckle clip) already fixed on the batten with brass pins and spaced 10cm horizontal and 15cm for vertical runs.



Figure 17: House Service Overhead System



Figure 18: House Service Overhead System

- i. In electric power distribution, a service drop is an overhead electrical line running from a utility pole, to a customer's building or other premises. It is the point where electric utilities provide power to their customers.
- ii. The customer connection to an underground distribution system is usually called a "service lateral". Conductors of a service drop or lateral are usually owned and maintained by the utility company, but some industrial drops are installed and owned by the customer.
- iii. At the customer's premises, the wires usually enter the building through a weatherhead that protects against entry of rain and snow, and drop down through conduit to an electric meter which measures and records the power used for billing purposes, then enters the main service panel.
- iv. The utility's portion of the system ends, and the customer's wiring begins, at the output socket of the electric meter.
- v. The service panel will contain a "main" fuse or circuit breaker, which controls all of the electric current entering the building at once, and a number of smaller fuses/breakers, which protect individual branch circuits.
- vi. There is always provision for all power to be cut off by operating either a single switch or small number of switches (maximum of six in the United States, for example); when circuit breakers are used this is provided by the main circuit breaker.

#### **Advantages of PVC sheath Wiring**

- i. Wiring installation is simple and easy

- ii. cheap as compared to other electrical wiring systems
- iii. Paraphrase is good and beautiful
- iv. Repairing is easy
- v. Customization can be easily done in this wiring system.
- vi. less chance of leakage current in batten wiring system

### **Disadvantages of PVC sheath Wiring**

- i. Cannot be installed in the humidity, Chemical effects, open and outdoor areas.
- ii. High risk of fires.
- iii. Not safe from external wear & tear and weather effects (because, the wires are openly visible to heat, dust, steam and smoke.
- iv. Heavy wires can't be used in batten wiring system.
- v. Only suitable below 250V.
- vi. Need more cables and wires.

### **Lead Sheathed wiring (mineral insulated metal sheath)**

The type of wiring employs conductors that are insulated with VIR and covered with an outer sheath of lead aluminium alloy containing about 95% of lead. The metal sheath gives protection to cables from mechanical damage, moisture and atmospheric corrosion.

The whole lead covering is made electrically continuous and is connected to earth at the point of entry to protect against electrolytic action due to leaking current and to provide safety in case the sheath becomes alive. The cables are run on wooden batten and fixed by means of link clips just as in TRS wiring.

### **Applications and benefits of mineral insulated cable (MIC)**

MI cable is a specialized type of cable used in high temperatures or harsh environmental conditions because it has low flammability, even when operating at high temperatures. It resists oxidation and enables precise measurement.

Mineral insulated cable consists of copper or thermocouple wires inside a copper, stainless steel, or Inconel® sheath, insulated by packed minerals such as magnesium oxide (MgO). Magnesium oxide makes an excellent electrical insulation material because it resists oxidation and ionizing radiation, and it is both chemically and physically stable at high temperatures. After the cable has been packed with MgO insulation, it may be rolled under pressure to achieve the desired diameter. The outer sheath protects the internal thermocouple wire from heat, chemical or other environmental damage. The metal sheath may be covered with an additional colored plastic



sheath to add in identification and to add an additional layer of protection from corrosion.

An MI cable may contain any number of wires, but the most common configurations include 1, 2 or 3 pairs of conductors. Specialized MI cables may include additional thermocouples in customized configurations. MI cable is available in a variety of diameters and lengths, depending on the specific requirements. Many MI cables are calibrated using sensitive, fast and highly accurate dry block probe calibrators.

RTD and thermocouple sensors manufactured from MI cable are used extensively in heat treating metals, solid waste incinerators, sintering powdered metals, firing ceramic materials, gas or oil-fired furnaces, fuel fired heat exchangers, box furnaces, and nuclear or hydrocarbon-based energy plants.

### Advantages of MI Cable



Figure 19: A Diagram on Advantaged of MI Cable

Molten Metal Oil Rig The metal sheath that clads MI cable helps to protect the thermocouple wires from oxidation when used in chemically active or wet environments. Corrosion resistance makes MI cable ideal for use in areas where failure and replacement could be dangerous or even impossible. For example, MI cable is used in nuclear plants to monitor core temperatures. It would be extremely dangerous if the temperature controllers were not receiving accurate readings, and it would be difficult to repair or replace cables in that environment.



The mineral fillings in MI cables provide excellent non-reactive insulation, preventing the thermocouple wires from contact with each other or with caustic substances such as oils, solvents or water. This helps to ensure that the thermocouple probes remain accurate, critical in applications such as heat treating or sintering where the quality of the product could be adversely affected by temperature fluctuations.

The insulation in MI cables does not burn, which makes it ideal for applications where fire could be catastrophic. Medical devices, power plants, and oil rigs are examples of places where installation of MI cables makes operations safer.

Since the thermocouple probes are protected from contact with other electrically active wires by the insulation, they are not readily subject to malfunction or inaccurate temperature measurements. Carefully calibrated to meet international standards, MI cables provide accurate and precise temperature measurement over long duty cycles with little or no loss of accuracy.

Because of the mineral insulation, MI cables can operate in high-temperature conditions with no loss of accuracy. This makes them ideal in kilns, firing ceramics or heat-treating metals or in any high-temperature process. MI cables retain their accuracy even during and after exposure to high temperatures, so they are ideal as a thermocouple probe in these operations. In addition, for industries such as medical devices or aerospace where safety standards are strictly enforced, process deviations could result in life-threatening quality issues. MI cables are carefully calibrated and verified using NIST standards at Omega against known temperatures or certified thermometers. NIST traceable calibration ensures temperature accuracy under actual operating conditions and provides documentation of their original accuracy. To remain NIST certified, the chain of verification must be intact and the thermocouples must be recalibrated as part of a well-documented and executed quality management system.

### **Properties and Advantages of Mineral Insulated Cables**

At room temperature and up to the more common application temperatures mineral powder insulates so well that the sheath can be considered to be entirely separated from the inner conductor. Consequently, there are no adverse effects if the conductor touches other metal parts of the equipment or is connected to them.

### **Long Life**

The construction of the cable guarantees a long conductor life and thus the function of the conductor because the sheath and the insulating powder protect the conductors (cores) against environmental conditions such as corrosion or scaling.

### **Easy Installation**

The cables are pliable, easy to handle and can be installed easily in a limited space or in locations where access is difficult. No additional insulation is required.

### **Mechanical Strength**

The compact construction with densely packed mineral powder and the robust metal sheath ensures the position of the conductors in the compound and thus the function of the cable even when exposed to mechanical stresses such as bending, twisting or flattening. The cable can also be used in pressure or vacuum equipment.

### **Safety**

Since the insulation is attained exclusively from powders on a mineral base the cables are fire-proof and can thus be exposed to considerably higher temperatures than cables with synthetic sheaths (e.g., PVC, teflon or textile fibres etc.).

### **Rapid Response**

The high density of the mineral powder effects rapid transmission of heat between conductor and sheath: This factor makes the cable highly suitable for temperature measurement and control techniques.

### **Dielectric Strength**

Despite its small size the compact construction allows an amazingly high dielectric strength conductor/conductor or conductor/sheath, respectively, which means the cables can be used in power supply systems at 220 V and above.

### **Radiation Resistance**

The correct choice of component ensures radiation resistance making possible the use of these cables in primary circuits as well as in the incore area, i.e. inside the actual reactor core.

### **Corrosion and Scaling Resistance**

The vast array of materials included in our standard programme and the possibility to make materials to specification has put us in a position to supply suitable sheath materials even for unfavorable environmental conditions in a corrosive atmosphere and at high temperatures. Depending on the choice of component the maximum application temperatures are between 500°C and 1000°C.

### **Long Lengths**

Long lengths of cable can be obtained due to the initial measurements before drawing and the production method.

### **Small Cable Diameter**

The relatively small diameter (compared with conventional cables) which is a result of the construction has many advantages for both customer and construction engineer.

### **Learning Activities**

- i. Identification of various types of cables and their areas of applications
- ii. Justification for the choice of different types of wiring system.

### **Self-Assessment**

1. What are the disadvantages of Polyvinyl Chloride?
2. What are hazards of PVC material?
3. What happens to PVC material as it ages?
4. Why is PVC used for cables?

### **Tools, Equipment and Materials**

- i. PPE including working gloves, overalls/dustcoats, safety shoes, helmets, goggles, safety harness.
- ii. Distribution boards
- iii. Consumer control units (complete with circuit breakers)
- iv. Utility boxes
- v. Screws
- vi. Accessories/fittings
- vii. Fasteners/clipper

viii. Junction boxes

## References

- i. <https://www.prysmiancable.com.au/construction/pvc-cables-recommended-installation-practices/>
- ii. <https://www.electricveda.com/building-services/wiring-materials-and-installation-methods-in-electrical-construction-works>

## Model Answers to Self-Assessment

### 1. Disadvantages of Polyvinyl Chloride

- i. Polyvinyl Chloride has very poor heat stability. For this reason, additives which stabilize the material at higher temperatures are typically added to the material during production.
- ii. Polyvinyl Chloride emits toxic fumes when melted and/or subject to a fire.

### 2. Hazards of PVC material

PVC contains dangerous chemical additives including phthalates, lead, cadmium, and/or organotins, which can be toxic to your child's health. These toxic additives can leach out or evaporate into the air over time, posing unnecessary dangers to children.

### 3. Effects of aging to PVC material

PVC get brittle with age, even in the ground, I can tell you that. PVC becomes increasingly brittle as the temperature drops. When exposed to freezing temperatures for prolonged periods of time, it can become brittle enough to crack quite easily.

### 4. Advantages of PVC used for cables

- i. PVC insulation is frequently used owing to its good insulating properties but low corona resistance, and is best suited for low and medium voltage cables and low frequency insulation requirements.
- ii. The benefits of PVC as cable insulation and sheathing material include its chemical stability, robustness and durability

## 1.3. Install electrical metallic/non-metallic (PVC) conduits

### Introduction

In this context, describes on how to install PVC conduits, learn on-site communications and electrical symbols for drawings that help in interpretation of electrical drawings and plans and finally on maintenance and storage of tools and equipment

### Performance Standard

- i. Interpretation of electrical drawings and plans
- ii. Identification and use
- iii. Storage of tools and equipment
- iv. Maintenance and storage of tools and equipment
- v. Materials specification
- vi. Use of materials

### **Information Sheet**

Interpretation of electrical drawings and plans

#### **On-site communications**

Good communication is about transferring information from one person to another.

Electricians and other professionals in the construction trades communicate with each other and the general public by means of drawings, sketches and symbols, in addition to what we say and do. drawings and diagrams Many different types of electrical drawing and diagram can be identified: layout, schematic, block, wiring and diagrams.

The type of diagram to be used in any particular application is the one which most clearly communicates the desired information.

**Layout drawings** -These are scale drawings based upon the architect's site plan of the building and show the positions of the electrical equipment which is to be installed.

The electrical equipment is identified by a graphical symbol. The standard symbols used by the electrical contracting industry are those recommended by the British Standard EN 60617, Graphical Symbols for Electrical Power, Telecommunications and Electronic Diagrams.

#### **Electrical symbol for drawing**

For electrical drawing, commonly used by contractor for electrical industry is the British Standard EN 60617 for Graphical Symbols for Electrical Power, Telecommunications and Electronic Diagrams.

This electrical symbol is easy to understand without complex shape or symbol to avoid confusing and it effected the work installation progress.

Below are some of the electrical symbols that are commonly used for electrical drawing. We can used from others symbol that suitable with our application and country code. The main purpose is to easier identified the electrical drawing for works installation.

Main control or intake point		Single-pole, one-way switch	
Main or submain switch		Note: Number of switches at one point may be indicated Two-pole, one-way switch	
Socket outlet (mains) general symbol		Three-pole, one-way switch	
Switched socket outlet		Cord-operated single-pole one-way switch	
Socket outlet with pilot lamp		Two-way switch	
Multiple socket outlet Example: for 3 plugs		Intermediate switch	
Push button		Lighting point or lamp: general symbol	
Luminous push button		Note: The number, power and type of the light source should be specified Example: Three 40 watt lamps	
Electric bell: general symbol		Lamp or lighting point: wall mounted	
Electric buzzer: general symbol		Emergency (safety) lighting point	
Time switch		Lighting point with built in switch	
Automatic fire detector		Projector or lamp with reflector	
		Spotlight	
		Single fluorescent lamp	

Figure 20: Electrical Symbols

This electrical symbol is different depend on country standard code and application. It not the big matter because the important thing is, we can do our electrical installation works in proper manner and completed it with successful.

### Here is an example of electrical wiring diagram

This is called by layout drawing. From these we easier can do our jobs with actual location for all equipment installation and electrical wiring purpose.

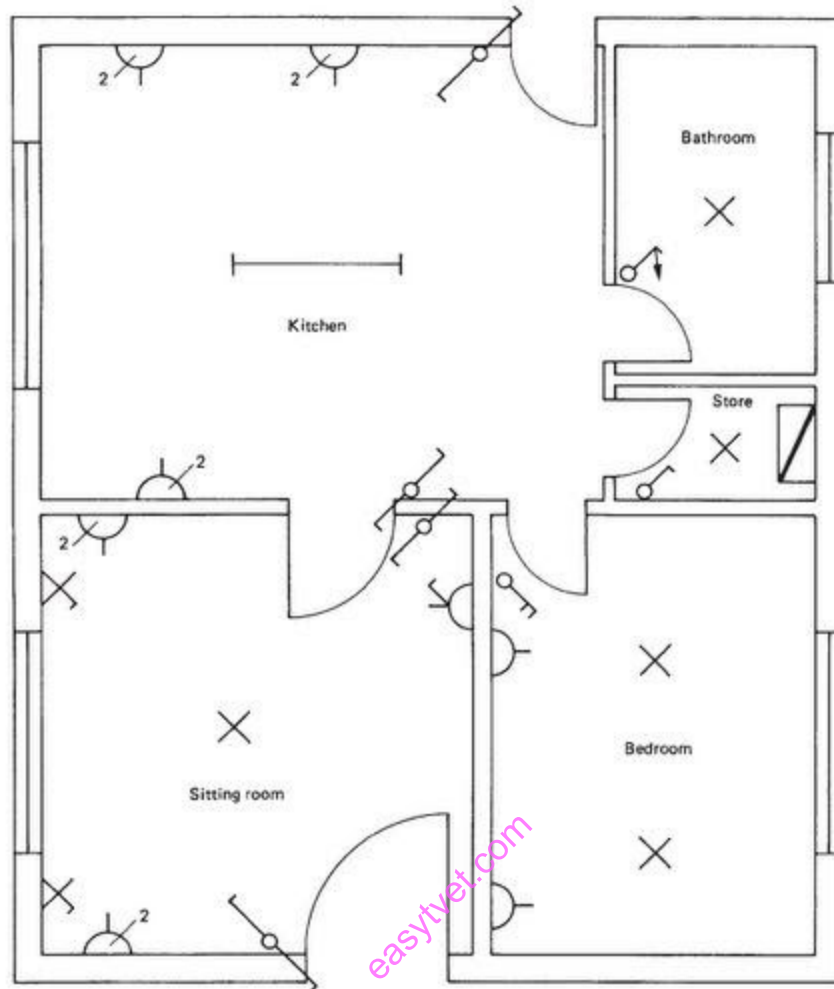

Figure 21: Layout drawing for electrical installation

- i. A layout drawing of a small domestic extension is shown in figure above.
- ii. It can be seen that the mains intake position, probably a consumer's unit, is situated in the store-room which also contains one light controlled by a switch at the door.
- iii. The bathroom contains one lighting point controlled by a one-way switch at the door.
- iv. The kitchen has two doors and a switch is installed at each door to control the fluorescent luminaire.
- v. There are also three double sockets situated around the kitchen.
- vi. The sitting room has a two-way switch at each door controlling the centre lighting point.
- vii. Two wall lights with built-in switches are to be wired, one at each side of the window. Two double sockets and one switched socket are also to be installed in the sitting room. The bedroom has two lighting points controlled independently by two one-way switches at the door.



## **The basic maintenance of electrical tools and equipment**

- i. Wipe the cords down to keep them from becoming damaged from oil and grease.
- ii. The prongs on the cords should be examined as well.
- iii. Make sure that the casing is intact and the prongs are not loose. The electric tools in your toolbox that have a cutting surface should be lightly oiled to prevent rust.

## **Installation of Conduits**

### **Types of Conduits**

- i. A conduit is a tube, channel or pipe in which insulated conductors are contained. The conduit in effect replaces the PVC outer sheath of a cable, providing mechanical protection for the insulated conductors.
- ii. A conduit installation can be rewired easily or altered at any time and this flexibility, coupled with mechanical protection, makes conduit installations popular for commercial and industrial applications.

Examples of types of conduit used in electrical installation work are as follows :

- i. Steel
- ii. PVC
- iii. Flexible
- iv. Stainless Steel

easyvet.com

## **Steel Conduit System**

### **Types and Sizes of Steel Conduit**

- i. Steel conduits are manufactured to specifications defined by the British Standards Institute (BS).
- ii. Class 4 conduit has a hot dip galvanized finish. It is of heavy gauge with a welded seam. This conduit is suitable for use in external or damp installations. This is the conduit most widely used in this country.
- iii. Note: The galvanized finish on conduit is to prevent the steel from corroding in normal use.
- iv. Also manufactured is a solid drawn seamless conduit which is more expensive and only used for special gas tight, explosion proof or flame proof installations.
- v. Conduit is normally supplied in 3 or 3.75 metre lengths and typical conduit external diameters are 16, 20, 25 and 32mm.

## **Eddy Currents in Steel Conduit**

Metal conduits in which a.c. circuit wiring is installed **MUST** contain all the current carrying conductors of each circuit in the same conduit, to eliminate the possibility of induced eddy currents. Eddy currents could result in the metal conduit and cables becoming hot.

### **Advantages of Steel Conduit**

- i. Affords cables good mechanical protection
- ii. Permits easy rewiring
- iii. Minimises fire risks.
- iv. Can be utilized as the Circuit Protective Conductor. ( CPC )

### **Disadvantages of Steel Conduit**

- i. Under certain conditions moisture is liable to form on the inside wall of the conduit.
- ii. Expensive compared with some other wiring systems.
- iii. Liable to corrosion where subject to acids, alkalis and corrosive fumes.

### **Cable Capacity of Steel Conduit (Space Factor)**

- i. Having determined the correct number and cross-sectional area of cables for a given load it is necessary to select the size of conduit that will accommodate them.
- ii. If a greater number of cables are installed in the conduit, over-heating, insulation damage and fire may result. As a general rule the number of cables drawn into a conduit should not be such as to cause damage to either the cables or the conduit during the installation.
- iii. The maximum number of cables which may be drawn into a conduit can be calculated by using the factor system described in the ETCI Rules.

### **Cutting Steel Conduit**

Conduit should be cut with a hacksaw, using a blade having 32 teeth / inch.

The cut should be made at right angles to avoid difficulty in threading the conduit.

- i. Hold conduit to be cut securely in a pipe vice. Avoid damage to the galvanised coating.
- ii. Stand square to the job and make sure your movement is unobstructed.
- iii. Grip the hacksaw lightly and apply light pressure on the forward cutting stroke. Use the full length of the blade.

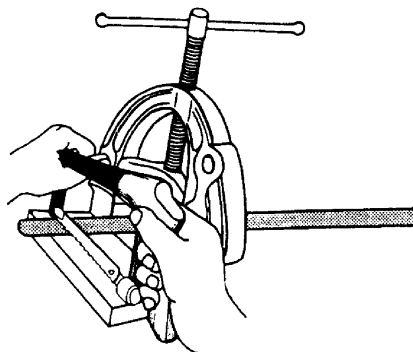

## Figure 22: Threading Steel Conduit

It is necessary to cut threads on the conduit ends in order to screw them into conduit couplings and accessory boxes. The conduit ends are threaded using stocks and dies. After threading the ends, all internal burrs must be removed to ensure that cables are not damaged as they are being drawn into the conduits.

All threaded ends must be screwed up tightly into accessories to ensure earth continuity.

- i. Hold the conduit securely in a pipe vice ( ensure that pipe vice jaw bolts are tight ).
- ii. While threading keep the die well lubricated preferably with a manufacturer’s paste or tallow.
- iii. Thread to required length and remove any burrs with a file or reamer, this will prevent sharp edges causing damage to cables while being drawn into the conduit.
- iv. To ensure a clean, unbroken thread the die should be rotated counter-clockwise frequently and finally run up and down the threads to remove any swarf ( metal fragments ).

### Fitting and Fixing Steel Conduit

Conduit must be securely fixed and where it is liable to mechanical damage, it should be suitably protected.

Drainage outlets must be provided at points where condensation is likely to collect.

#### Spacing of Supports for Conduits

The table below shows a suggested spacing of supports for steel conduits up to 25mm in diameter. Supports should be positioned within 300mm of bends and fittings. The table assumes that the conduit is not subject to other external mechanical stresses.

Conduit Size	Horizontal Runs	Vertical Runs
Not exceeding 16mm	750mm	1000mm
20-25mm	1750mm	2000mm

### Saddle Spacing of Supports for Conduits

A range of clips and saddles are available for conduit installations. The spacer bar saddle, is the device most commonly used for fixing conduit, see Figure 2. They provide a very secure method of fixing and generally should be spaced as per the table on the previous page.

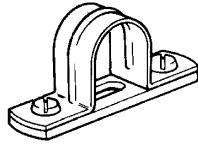

Spacer bar saddles incorporate a spacing plate. These spacing plates are approximately 5mm thick. This spacing plate tends to align the conduit with the knockouts in switch and socket outlet boxes. On vertical runs ensure that saddles are fitted the correct way round. An important function of the spacer bar saddle is to keep the conduit out of contact with plaster and cement surfaces. Contact between conduit and these surfaces could result in corrosion of the conduit and discolourment of the surfaces.

When a conduit is fixed to concrete, much installation time is spent in plugging the concrete for fixings. Spacer bar saddles have the advantage of a central, single-hole fixing. The additional cost of spacer bar saddles over the plain saddle can be offset against the saving in time and effort required in fixing.

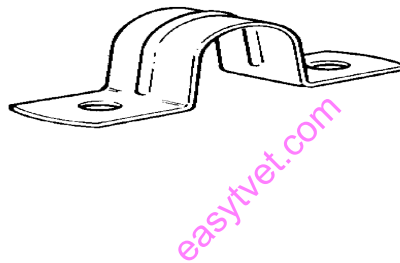

### **Distance Saddles**

Distance saddles are designed to space the conduit approximately 10mm from the wall or ceiling. These saddles are generally made of malleable cast iron. They are much more substantial than spacer bar saddles and the additional spacing provides greater protection against corrosion. The use of distance saddles eliminates the possibility of dust and dirt collecting behind the conduit. By adequate spacing it is possible to keep the conduits free of dust and it is for this reason distance saddles and hospital saddles are generally specified.

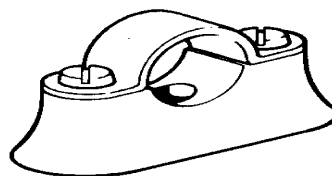
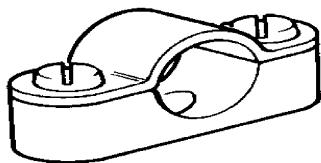

Figure 23: Distance Saddles

### **Multiple Saddles**

Where two or more conduits follow the same route, it is generally an advantage to use multiple saddles. Proper spacing of the conduits ensures that there is no need to set the conduits where they enter conduit accessories

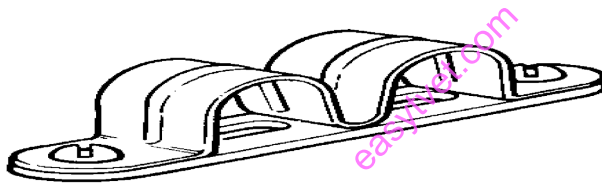

Figure 24: Multiple Saddles

### **Termination of Steel Conduit to Enclosures**

Two methods of terminating steel conduit are commonly used.

- a) The coupling and male bush method
- b) The locknut and female bush method

#### **Coupling and Male bush Method**

The coupling and male bush method is slightly more expensive than the locknut and female bush method but it allows more wiring space and is a stronger form of termination. Using this method a coupling is screwed securely on to a standard threaded conduit end and then butted against the accessory box. A male bush is passed through the box entry and screwed tightly into the coupling using an open-ended spanner or a bushing spanner.

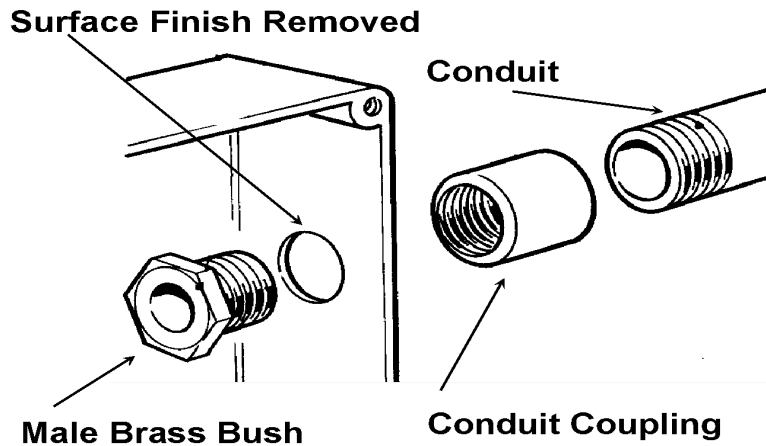

Figure 25: Coupling and Male Bush Method

### Locknut and Female Brass Bush Method

Using this method a locknut is screwed tightly onto a standard threaded conduit end and the thread passed through the hole in the accessory box. A second locknut is screwed onto the conduit effectively sandwiching the wall of the box. To prevent damage to cables, from the exposed end of the conduit, a female bush is then screwed onto the conduit thread. One disadvantage in using this method of terminating a conduit to a switch or socket box is that the conduit protrudes into the box and may inhibit the fixing of the switch or socket.

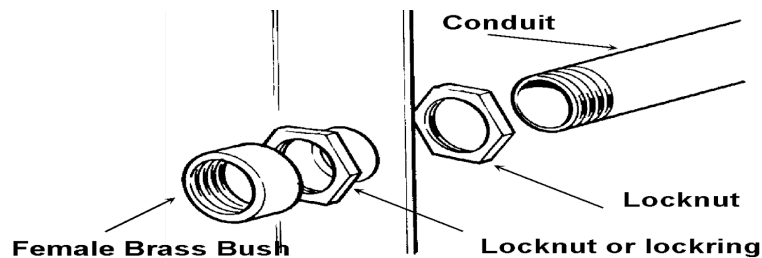

Figure 26: Locknut and Female Brass Bush Method

Note: - These are earth terminations

### Galvanized Steel Conduit Accessories

Illustrates a range of galvanised steel conduit boxes, reducers and adaptors.

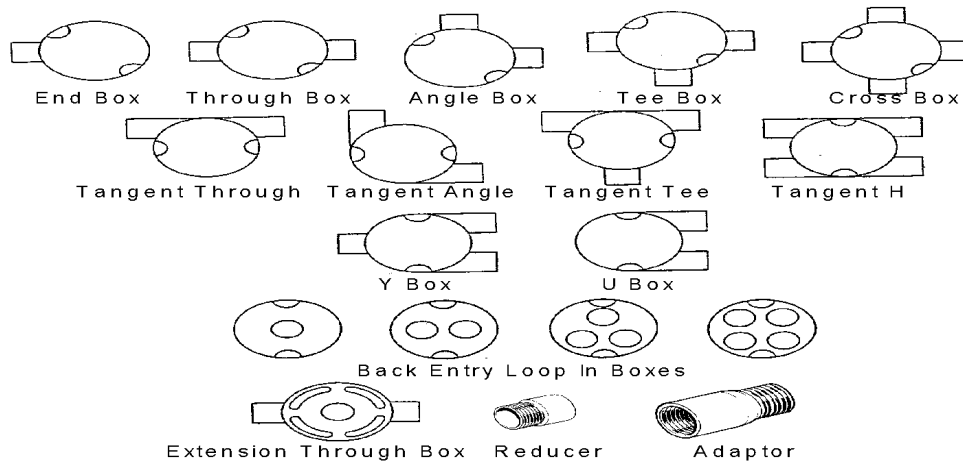

Figure 27: Galvanized Steel Conduit Accessories

### Jointing Steel Conduit

Where two lengths of conduit are to be joined a plain coupling is used. To ensure good electrical continuity and maximum mechanical strength the tube ends must tighten inside the coupling (Max gap 2 mm). Care must be exercised to do this without leaving threads outside the coupling.

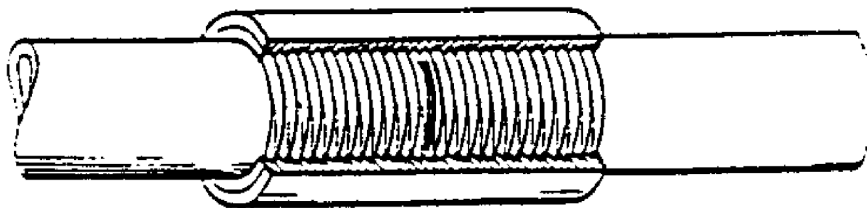
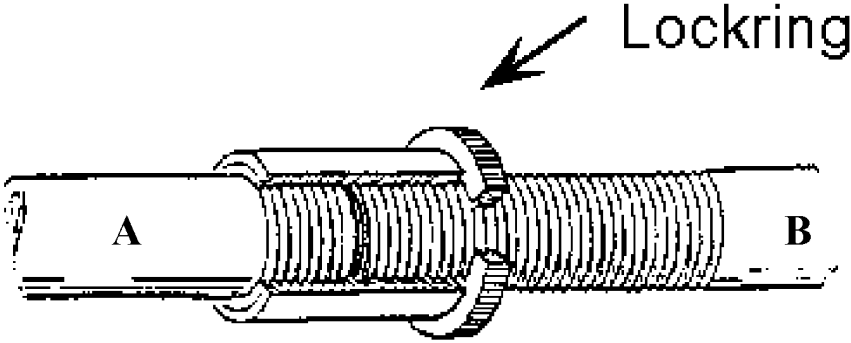

Figure 28: Jointing Steel Conduit

Where neither tube can be turned it is necessary to resort to the technique known as the “running coupling”. After tightening up the locking the exposed thread must be painted to prevent corrosion.



**Setting up Sequence of a Bending Machine**

Place the semi-circular former 'B' (to suit the size of conduit to be bent) in position and secure the centre-pin.

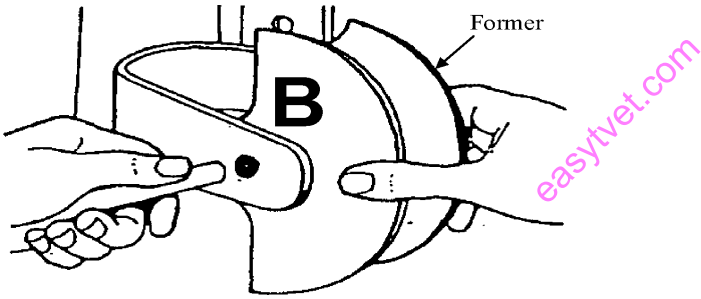

Position the stop 'C' in the correct position for size of conduit.



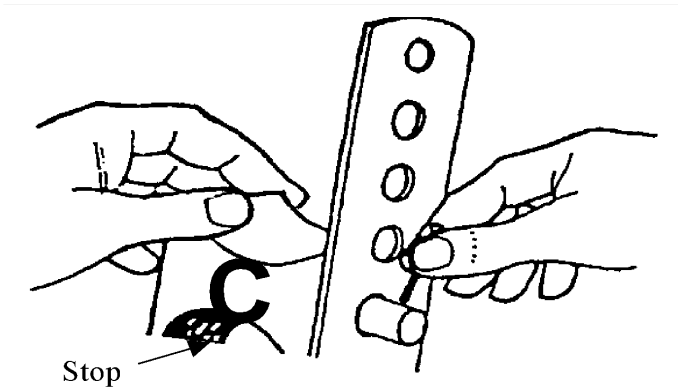

Insert the grooved roller in the correct position for size of conduit.

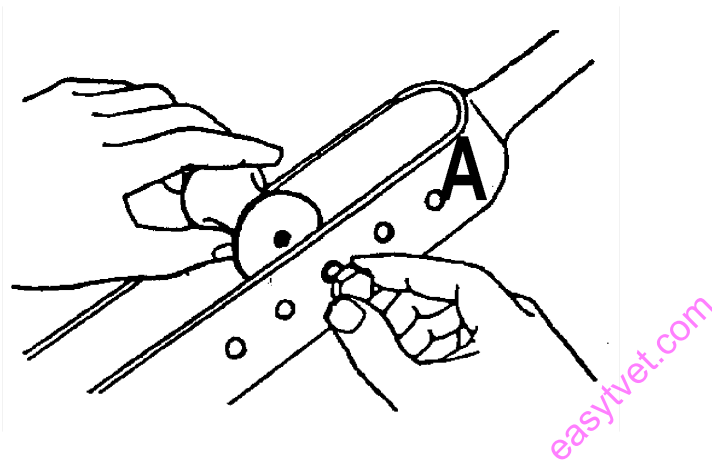

### **Bending Steel Conduit**

The most common method of bending steel conduit is to use a bending machine. However, for bending 32mm diameter or larger conduits it is recommended to use a portable ratchet bender. The following are the main steps to be taken when using a bending machine.

- i. Insert the conduit under the stop and into the groove in the former.
- ii. Pull down the handle, allowing the roller to bend the conduit around the former.
- iii. Use a template to compare the angle of the bend formed with the desired angle.

Bends should be formed to an internal radius of not less than 2.5 times the conduit diameter

#### **Making a 90° Bend in Steel Conduit**

Illustration of a right-angle bend in steel conduit, which must be formed to a dimension of 200mm.

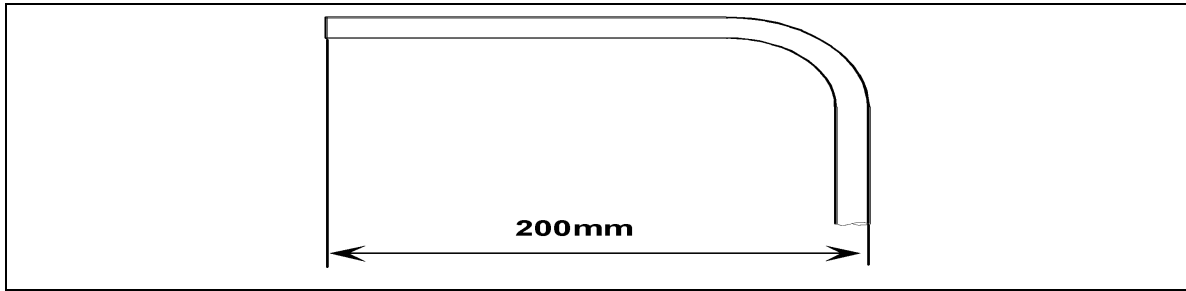
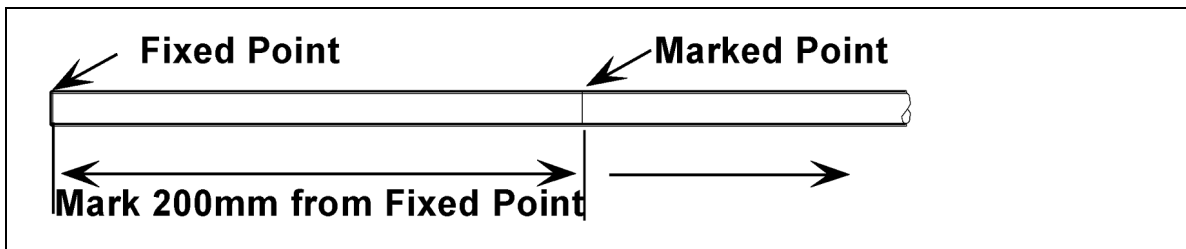
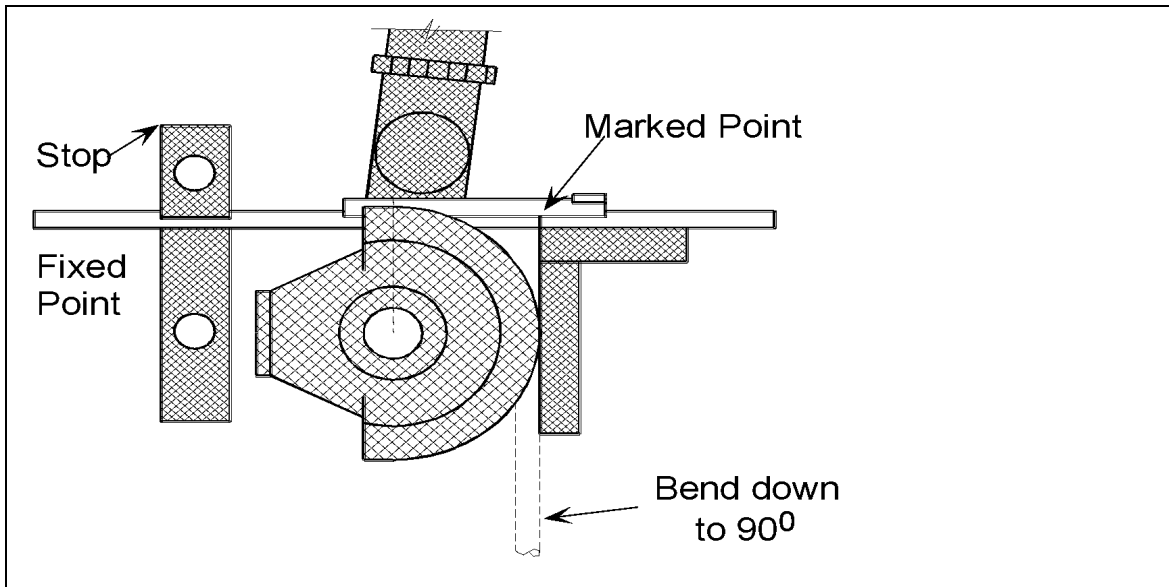

Figure 29: Bending Steel Conduit

The first step is to mark off 200mm from the end of the conduit as illustrated in Figure 12.



The next step is to place the conduit in the former with the mark to the rear. Position the conduit so that a try-square, held against the mark touches and forms a tangent to the edge of the former as illustrated below.



Next pull the lever down until the 90° angle, is achieved.

## Making a Double Set or Offset in Steel Conduit

Normally offsets should be formed at either 30° or 45°.

A 30° offset is preferred for two reasons:

- i. Ease of measurement.
- ii. Ease of drawing-in cables.

### Forming of a 30° Offset

Figure 14 illustrates a 30° offset to be formed in steel conduit. From the illustration it can be seen that the 30° angle is one of three angles forming a right angled triangle.

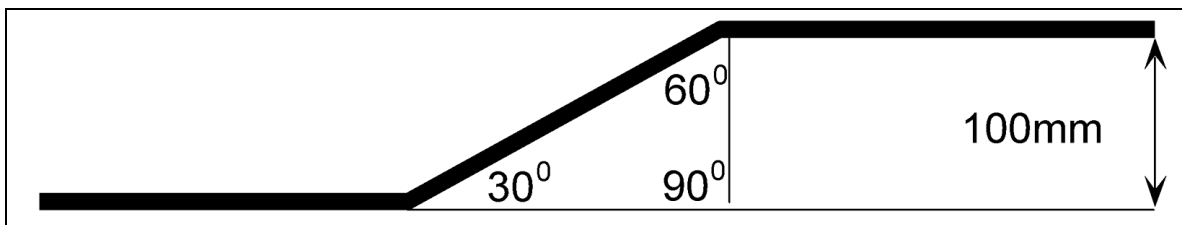

A rule of thumb for a right-angle triangle (30°, 60°, 90°) states that the relationship between the three sides is in the ratio of 1:2:√3, see Figure 1.67.

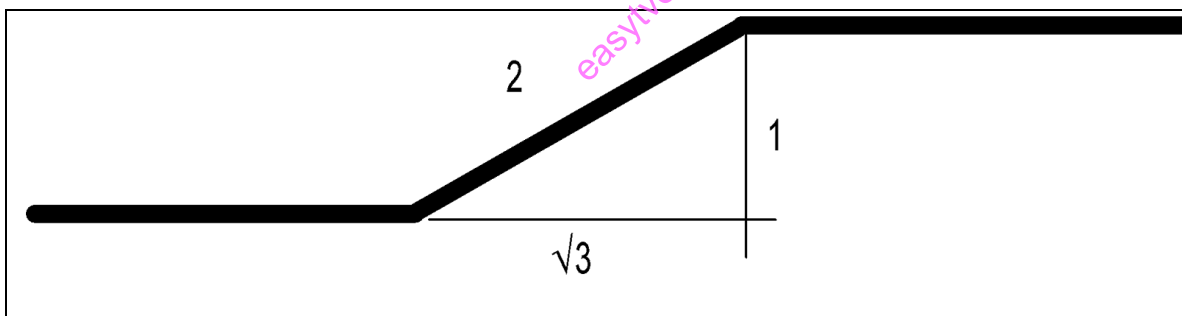
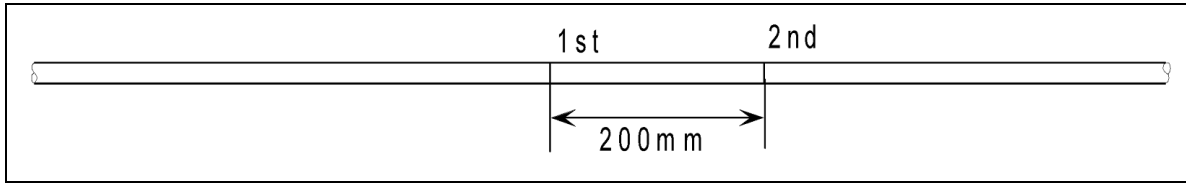
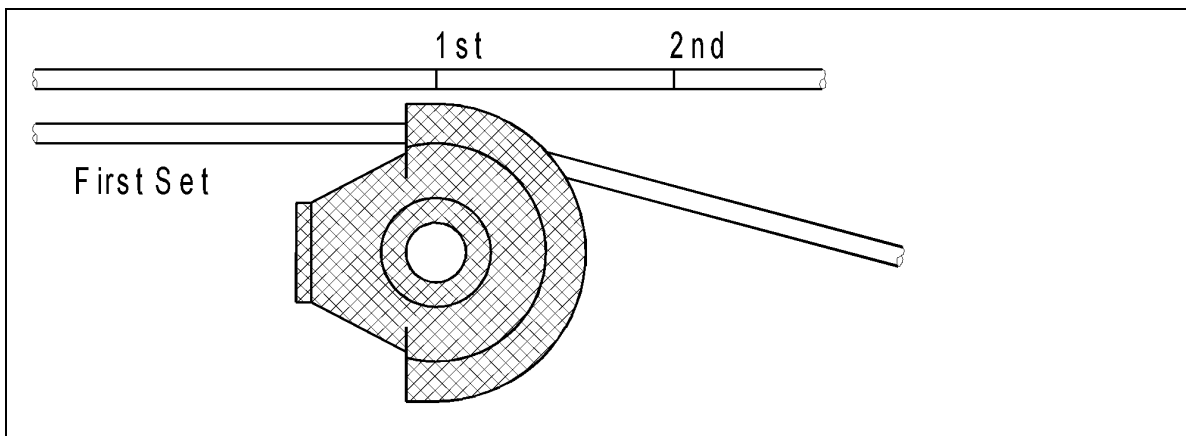
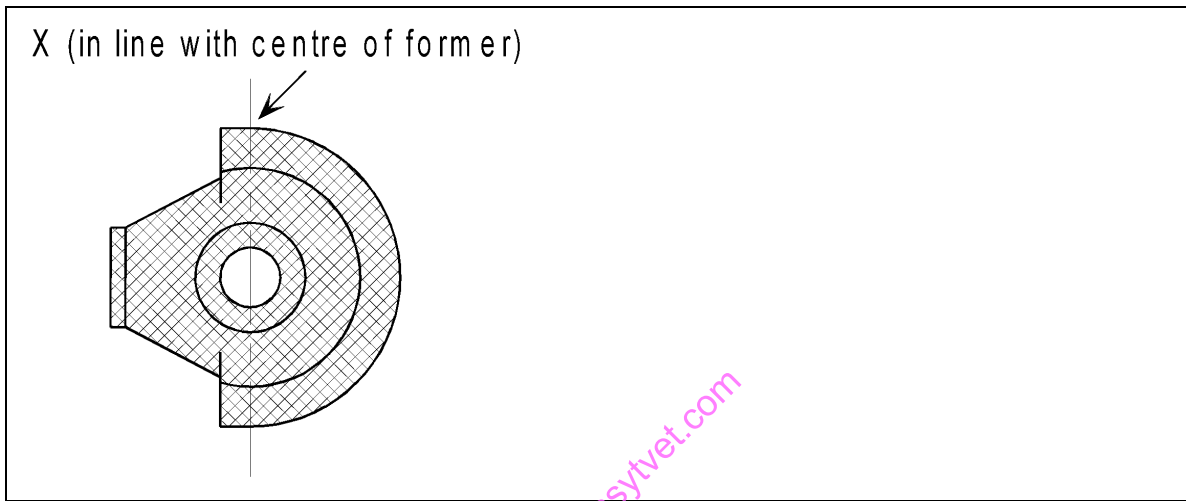

Figure 30: Forming of a 30 Degrees Offset

With this information, once we know the dimension of the offset (100mm in this case) we can now calculate and mark off the distance between the two bends. At this point take the straight piece of conduit and mark on it where you want the first bend to start from, then measure 200mm from that point to where the second bend starts.



Now go to the bending machine. Mark a point on the former as shown in Figure 17. Place the conduit in the former matching the first mark on the conduit with the mark on the former and bend to  $30^\circ$  as shown in Figure 18. Now remove the conduit and check the offset angle against a  $30^\circ$  template.



Place the conduit back in the machine pointing in the same direction as before but inverted and match the second mark on the conduit with the mark on the former, see Figure 19. The second offset is now formed until it is in parallel with the first offset.

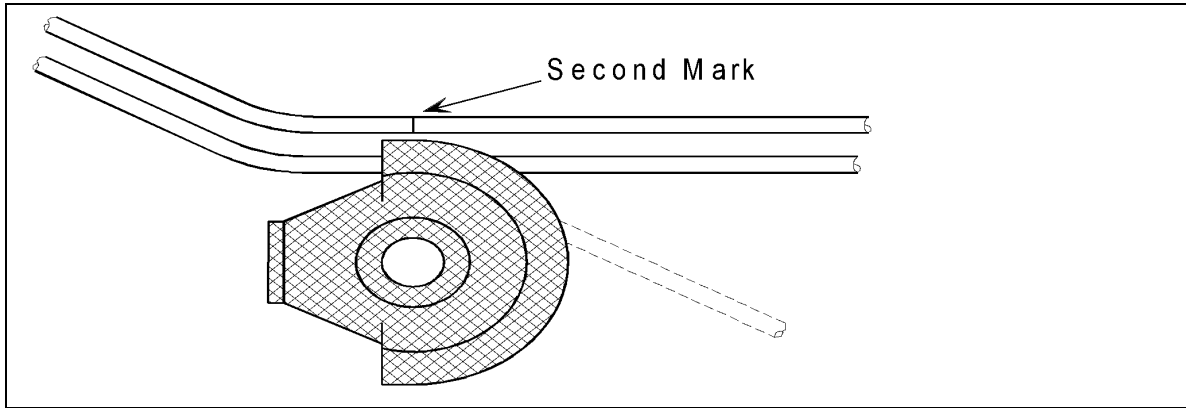

### Forming a 45° Offset

A 45° degree offset is formed in exactly the same manner as the 30° version except that the measurements between the first and second bends are calculated using the following formula 1:1:√2. Figure 20 illustrates the use of this formula, in this case  $\sqrt{2} = 141\text{mm}$  or  $100 \times \sqrt{2} = 141\text{mm}$ .

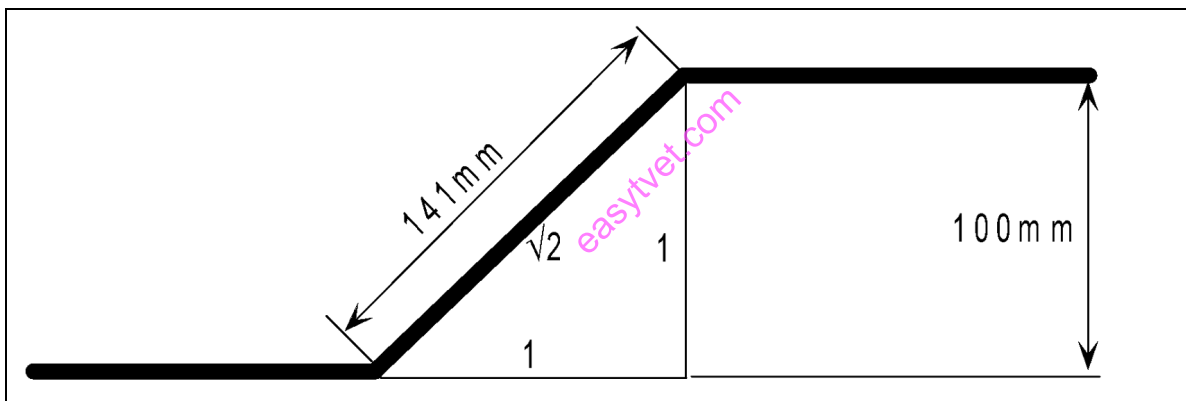

### Making a Saddle Set (Jump) in Steel Conduit

Assume you are required to form a saddle set with a clearance of 30mm as illustrated below.

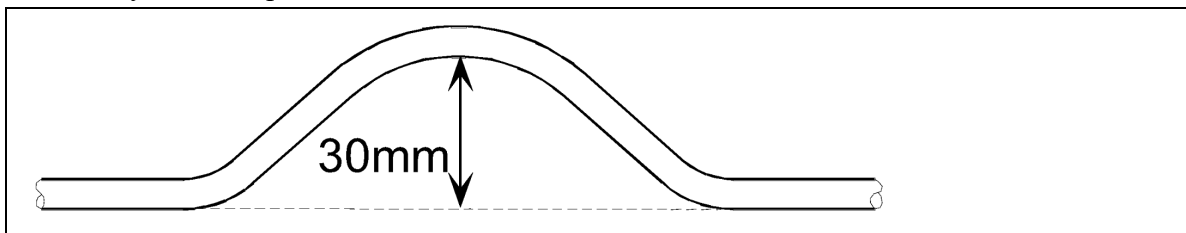

The first step is to bend the conduit to an angle of 45° as shown below.

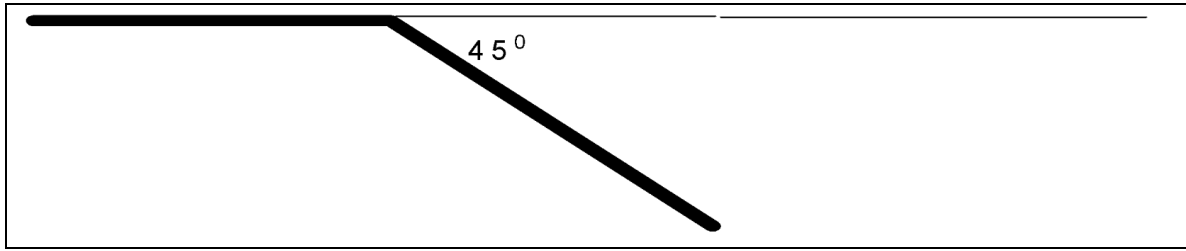

Figure 31: Forming a 45 Degrees Offset

The following formula will help you calculate the position of the next two bends which must be formed in order to achieve the 30mm clearance required.

Sine of the Angle = Opposite/Hypotenuse

$$\text{Sine } 22.5 = 30/\text{Hypotenuse}$$

$$\text{Hypotenuse} = 30/\text{Sine } 22.5$$

$$\text{Hypotenuse} = 30/.3827 \text{ mm}$$

$$\text{Hypotenuse} = 78\text{mm.}$$

Illustration of the application of the formula.

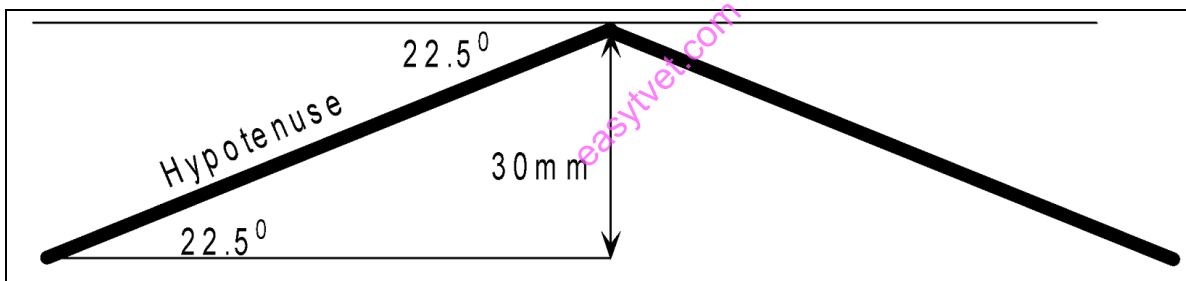

Mark the conduit as shown in Figure 1.76.

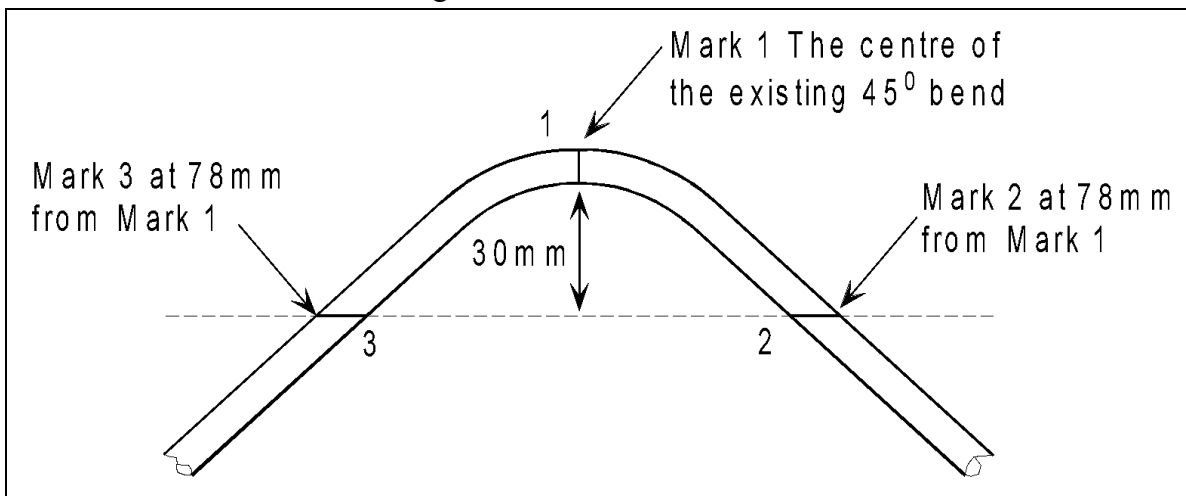

Marks 2 and 3 may also be located using a straight edge or other method.

Place the conduit in the machine so that mark 2 is opposite the existing mark on the former, and bend downwards as shown in Figure 1.77

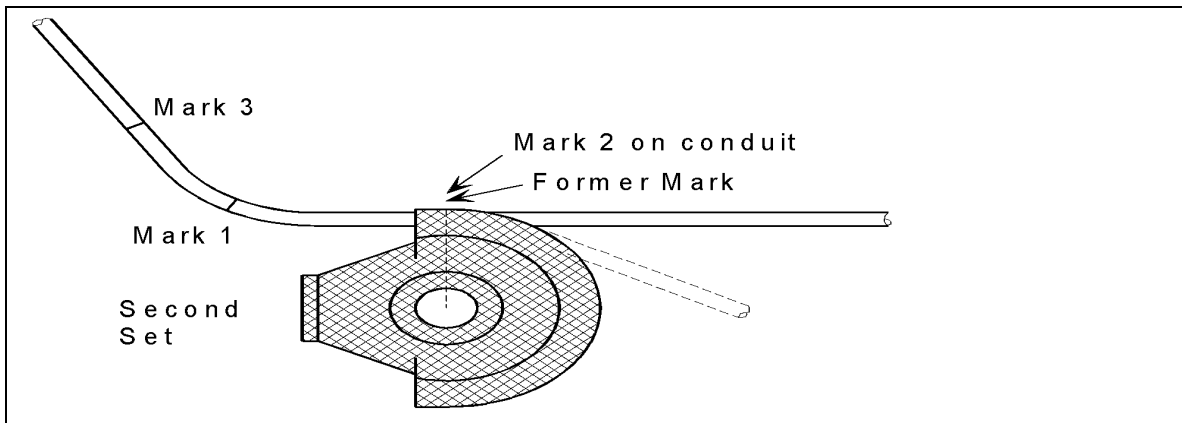

Reverse the conduit in the former and match mark 3 with the existing former mark. Bend down until the edges of the conduit are in line, see Figure 1.78

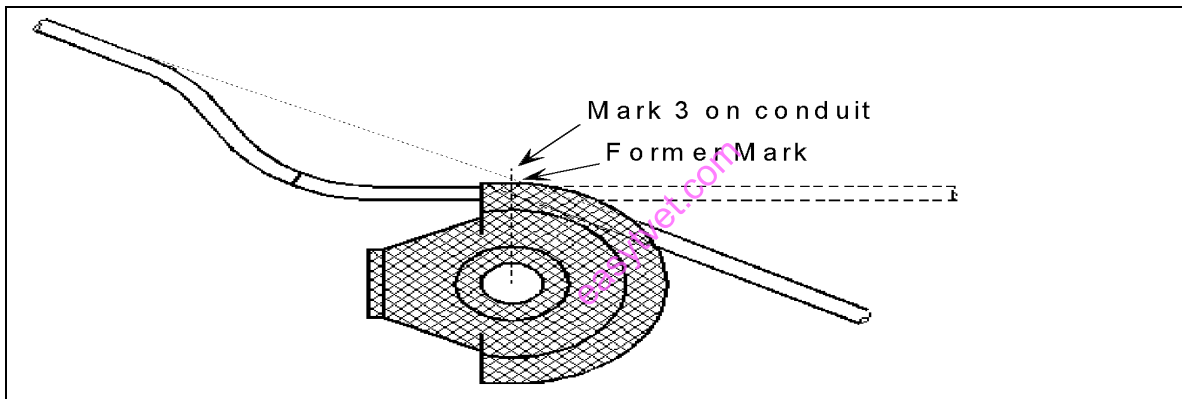

### Making a Double 90° Bend in Steel Conduit

Measurements for a double 90° bend in steel conduit can be taken using any of the three methods shown in Figure 1.79

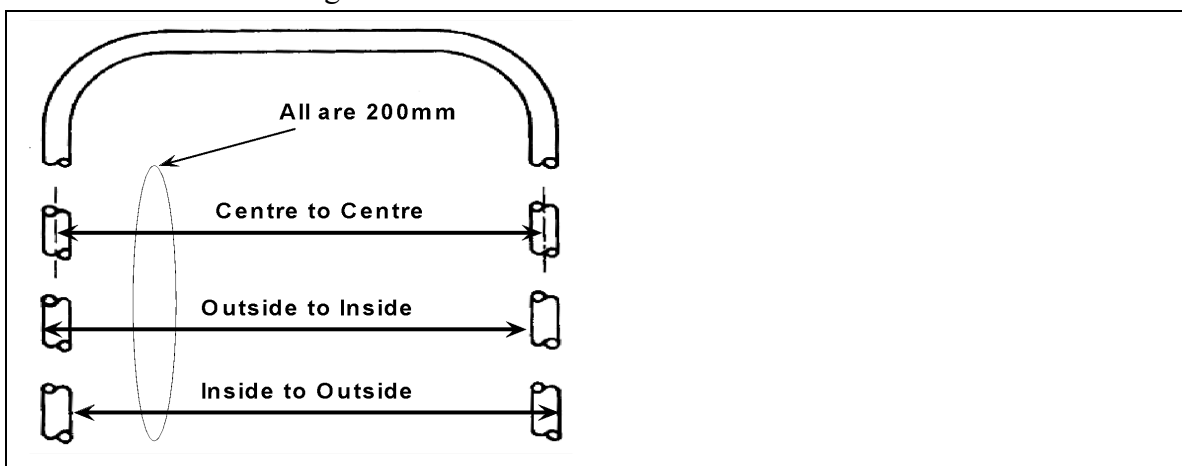
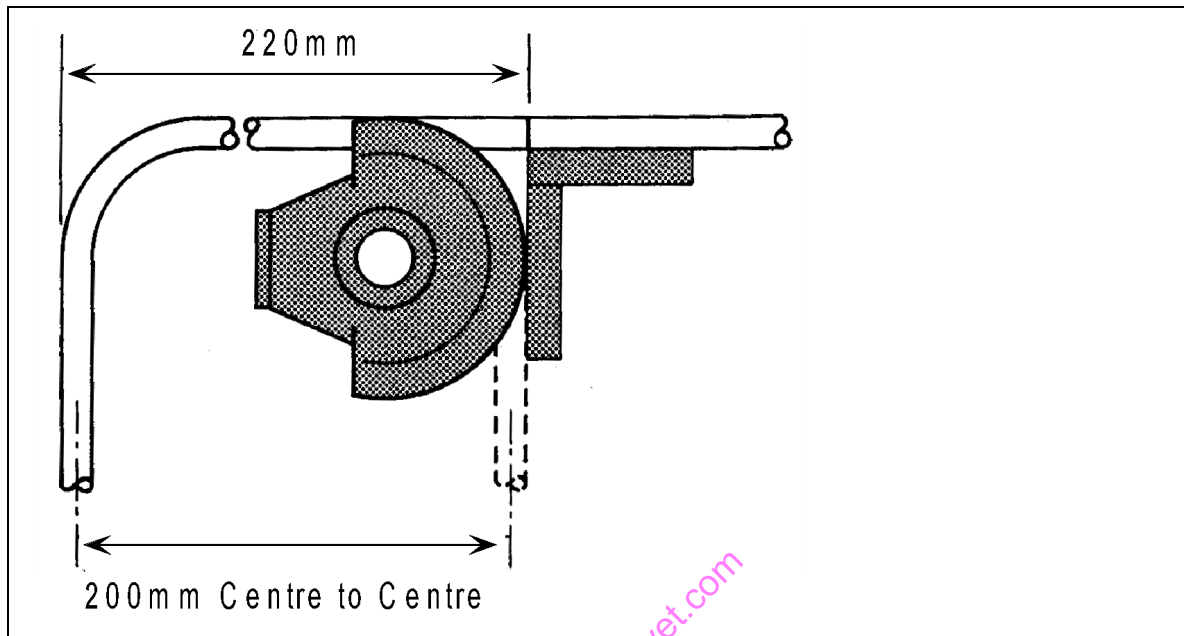

Figure 32: Making a Double 90 Degrees Bend on a Steel Conduit

If you add the outside diameter of the conduit (20mm) to the centre to centre measurements (200mm) we can now mark the position of the second bend (220mm), see Figure 28. Bend down until the 90° angle is achieved.



Note: - The above methods may require adjustments due to manufacturer's tolerances and wear in different bending machines

### Steps in Preparing Steel Conduit Installation

- Step 1: Anchor Boxes. Anchor metal boxes to the wall with screws.
- Step 2: Measure Conduit. Once the boxes are installed, measure the conduit for cutting.
- Step 3: Cut Conduit. Cut the conduit to fit with a hacksaw.
- Step 4: Slide in Conduit.
- Step 5: Anchor Conduit.



### Step 1: Anchor Boxes



Figure 33: Step 1, Anchor Boxes

Anchor metal boxes to the wall with screws. For exposed wiring use handy boxes, which have rounded edges and metal covers. An offset fitting allows the conduit to run tight up against the wall.

### Step 2: Measure Conduit

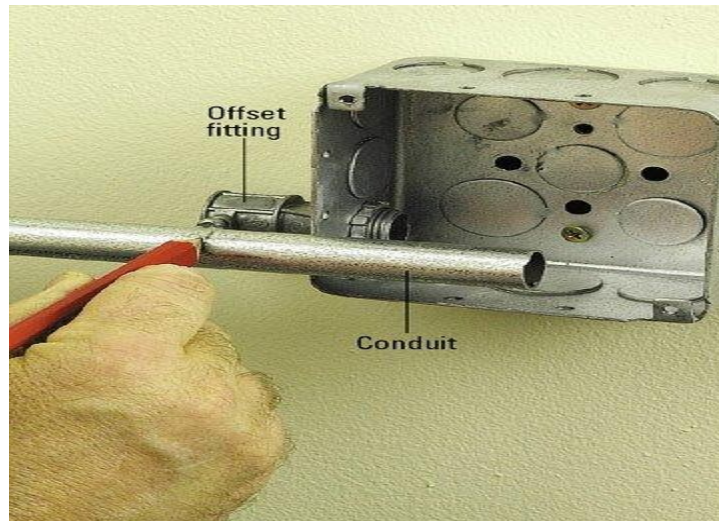

**Figure 34: Step 2, Measure Conduit**

Once the boxes are installed, measure the conduit for cutting. The surest method is to hold a piece in place and mark it, rather than using a tape measure. Remember that the conduit slides about an inch into each fitting.

### **Step 3: Cut Conduit**



**Figure 35: Step 3, Cut Conduit**

Cut the conduit to fit with a hacksaw. Do not use a tubing cutter, which creates sharp edges inside the conduit that could damage wire insulation. Remove the burrs inside and out with a conduit-reaming attachment on a screwdriver.

#### Step 4: Slide in Conduit

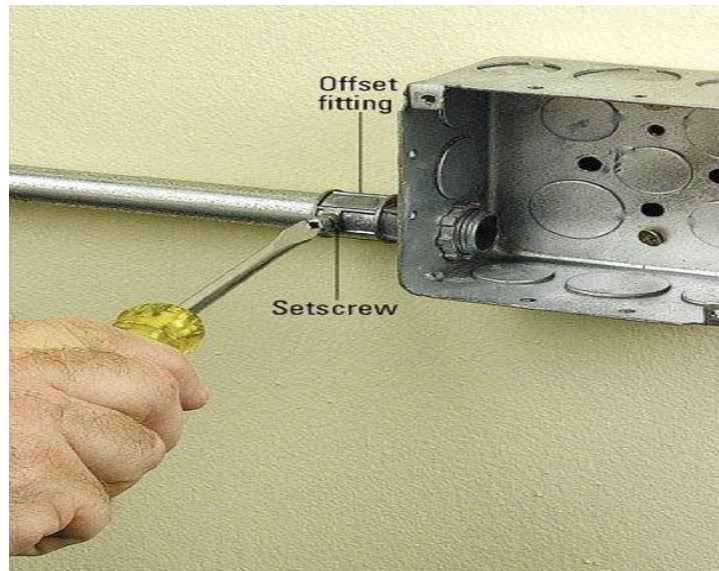

Figure 36: Step 4 Slide in Conduit

Slide the conduit all the way into a fitting and tighten the setscrew. Test to make sure the connection is tight. (If you are not installing a ground wire, these connections are critical for grounding.)

Make sure the wires have ample room inside the conduit to slide through easily. Codes have detailed rules regarding conduit size, but generally 1/2-inch conduit is large enough for five or fewer wires; 3/4-inch conduit is used for more than five wires. When in doubt or if you might run more wire in the future, buy the larger size—it doesn't cost much more.

#### Step 5: Anchor Conduit



Figure 37: Step 5 Anchor Conduit

Anchor the conduit with a one-or two-hole strap at least every 6 feet and within 2 feet of each box. The larger the conduit, the closer the straps need to be. Check with local codes. Screws should be driven into joists or studs, not just drywall.

#### **Additional step to Install a Pulling Elbow**



Figure 38: Additional Step to Install a Pulling Elbow



With every turn it gets harder for the wires to slide through a conduit. If the conduit makes more than three turns before entering a box, install a pulling elbow. Never make a splice here; just use it as an access point when pulling wires.

### **Installation of PVC conduit**

Electrical conduit fittings form the outer covering for most electrical wiring from one point to the next. They shield the wires from the external environment so as to make the wire last longer and also to keep humans and pets safe from electric shocks or other such vulnerabilities. Electrical conduits are predominantly made of insulating and sturdy material for optimum functionality.

### **Composition of PVC Conduit**

The basic material is poly-vinyl-chloride ( PVC ) which is produced in both flexible and rigid forms. It is impervious to acids, alkalis, oil, aggressive soils, fungi and bacteria and is unaffected by sea, and air. It withstands all pests and does not attract rodents.

PVC conduit may be buried in lime, concrete or plaster without harmful effects.

### **Choice of PVC Conduit**

The choice is dependant on the type of work being undertaken and the job specification.

- i. Heavy gauge round conduit is normally used in surface work and for forming on-site.
- ii. Light gauge round conduit is suitable for concealed work.
- iii. Oval conduit is normally chosen for use in plaster walls and can be used for drops in surface work.

Typical electrical installations use a heavy guage standard impact tube manufactured to BS 4607. The conduit sizes and range of fittings are the same as those available for metal conduit.

### **Jointing PVC Conduit**

PVC conduit is most often jointed by placing the end of the conduit into the appropriate fitting. Joints into accessories can be easily made dry or by the use of silicone grease or a permanent solvent, dependant on the installation conditions. The silicone grease should be used for expansion couplings and where an installation may be subject to future alteration.

### **Precautions When Using Adhesives**

Care should be taken when using adhesives, which are pro-chemical based, and as such are quite flammable and volatile.

- i. Replace the lid on the tin immediately after use.
- ii. Use in a ventilated area away from naked flame.
- iii. If adhesive should get into your eyes, seek first-aid immediately.

## Expansion of PVC Conduit

Expansion couplings should be used for surface installations at a recommended maximum of 4 metre intervals.

Where frequent variations in ambient temperature are likely to occur this distance must be greatly reduced.

Note: PVC conduit is not suitable for installations subject to temperatures below -5oC or above 65oC

## Fitting and Fixing of PVC Conduit

A range of fixings for PVC conduit is available as shown below.

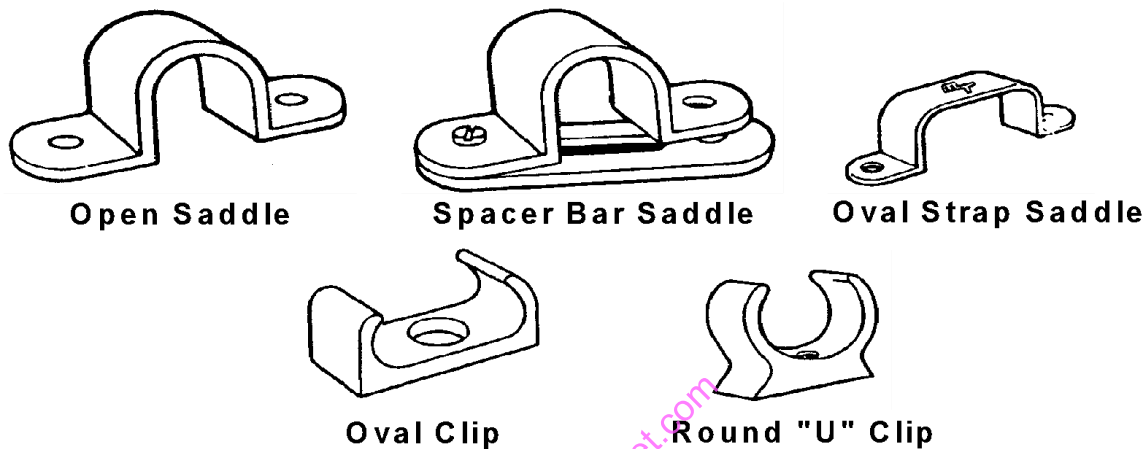

Figure 39: Fitting and Fixing of PVC Conduit

PVC conduit is fixed in the same way as metal conduit. All horizontal runs should be saddled at not more than 900 mm intervals unless high ambient temperatures or rapid changes in temperature are likely to be encountered, when the intervals should be reduced.

Vertical runs should be saddled at not more than 1200 mm intervals except where directional changes are made. Saddles should be installed approximately 150 mm either side of a bend. Conduit should be able to move freely in the saddle.

## Advantages of PVC Conduit

- i. Lightweight and easy to handle
- ii. Easy to cut and deburr
- iii. Simple to form and bend
- iv. Does not require painting
- v. Minimal condensation due to low thermal conductivity in wall of conduit.
- vi. Speed of installation
- vii. Excellent electrical and fire resistant properties

## Disadvantages of PVC Conduit

- i. Care must be taken when glueing joints to avoid forming a barrier across the inside of the conduit.
- ii. If insufficient adhesive is used the joints may not be waterproof.
- iii. PVC expands about 5 times as much as steel and this expansion must be allowed for.
- iv. PVC does not offer the same level of mechanical protection as steel.
- v. A separate Circuit Protective Conductor must be run inside the conduit.

### Working with PVC Conduit

- i. PVC conduit is easily cut using a junior hack saw. Any roughness of cut and burrs should be removed with the aid of knife blade or simply by wiping with a cloth. There are proprietary tools available for cutting PVC conduit.
- ii. Cold bending of PVC conduit may be carried out on conduit sizes up to 25mm diameter using a bending spring, see Figure 30. It is essential to use the correct size bending spring and it should be noted that springs for heavy gauge conduit are colour coded green and those for light gauge conduit are colour coded white. They are not interchangeable.
- iii. It is important that the spring is not damaged or kinked. A faulty spring can cause the conduit to kink and fracture. The spring can also jam inside the bend.
- iv. The radius of the bends should be as near as possible to that of a similar bend formed in steel conduit of a similar size.



Having inserted the spring into the conduit, grip the conduit on either side of the proposed bend and bend the conduit slowly, as illustrated below.

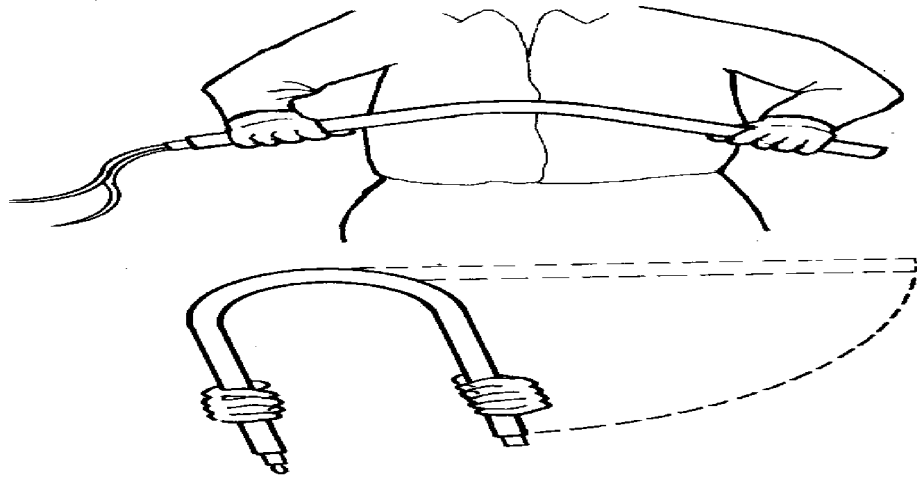

- v. The conduit should be bent to a more acute angle than the angle finally desired because of the tendency of PVC to “recover” after bending. This tendency lessens as the temperature decreases.
- vi. In very cold weather it is recommended that the conduit is warmed slightly by rubbing with a cloth held in the hand. If the conduit is bent too quickly there is a risk of kinking and / or fracturing of the conduit and possible damage to the bending spring.
- vii. If the conduit is intended for surface work it should be saddled and fixed as soon as possible after bending. Once a bend has been formed it should not be forced backwards as this can damage both the conduit and the spring.
- viii. To remove the spring, twist it in an anti-clockwise direction. This will reduce the diameter of the spring and make it possible to pull the conduit and spring apart. If the spring jams during this operation do not pull hard on it, otherwise the spring will be damaged.

### Hot Bending of PVC Conduit

- i. Hot bending of conduit should be carried out on sizes over 25mm diameter. A bending spring of the correct size should be used. Apply a gentle heat preferably with a hot air torch, electric heating element or hot water. Bend the conduit in accordance with above instructions.
- ii. Care should be taken to avoid the direct application of flame to the conduit. When the conduit is in a pliable state it should be slowly bent around a suitable former and held in position for about one minute until set. After setting, the bending spring may be twisted anti-clockwise and removed.

### Steps in Preparing a Pvc Conduit Installation

- i. Choose the right material for installing electrical conduit fittings
- ii. Chalk out a wiring plan
- iii. Measure the amount of conduit that you would need



- iv. Make the necessary bends
- v. Attach fittings to the wall

**Step 1: Choose the right material for installing electrical conduit fittings**

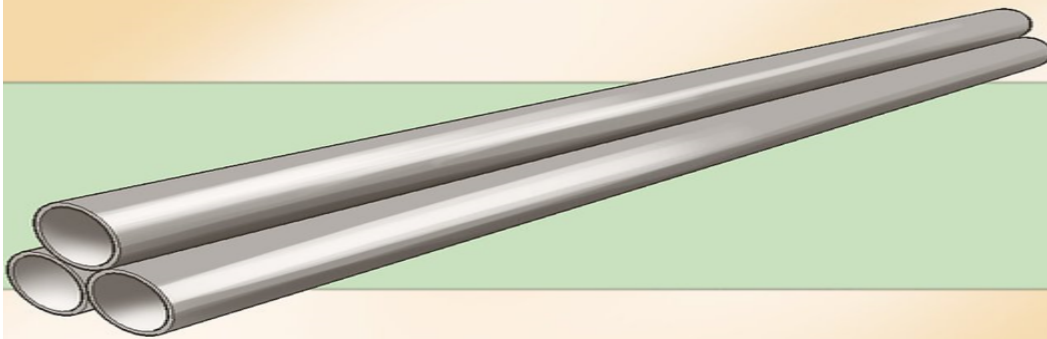

Figure 40: Choosing the Right Material for Installing Electrical Conduit Fittings

The most preferred material is known as EMT (Electrical Metallic Tubing). EMT is very easy to install as you can effortlessly bend it and assemble it as per your needs. Also, you can conveniently take it off in case your wiring goes wrong somewhere. If you do not have it in your house, you can buy EMT from any of the electrical surplus stores for pretty cheap.

**Step 2: Chalk out a wiring plan**

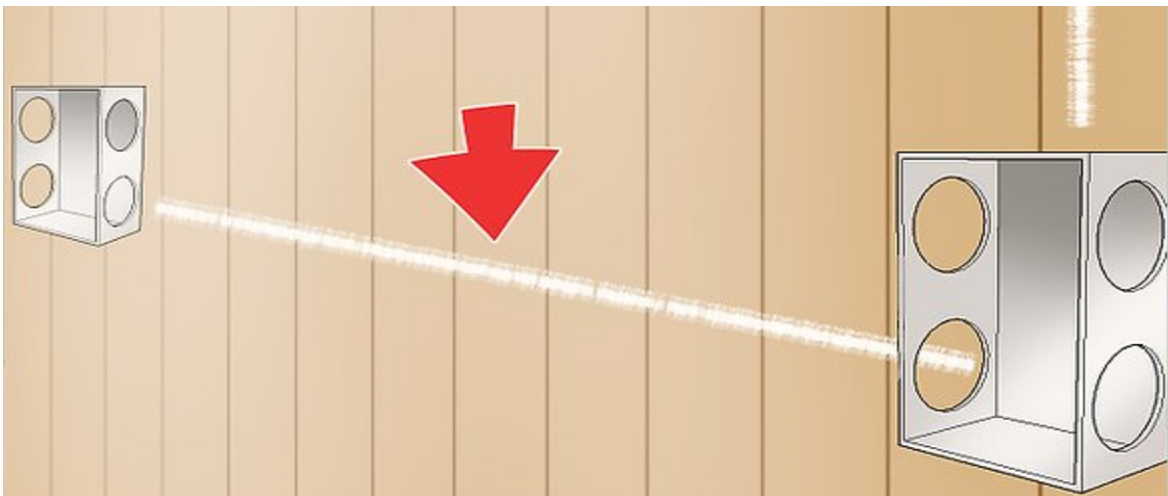

Figure 41: Chalk out a wiring plan

Find out the location of the electrical boxes on your wall to trace the route of the conduit. Draw the path from the main power source to the electrical box.

**Step3: Measure the amount of conduit that you would need**

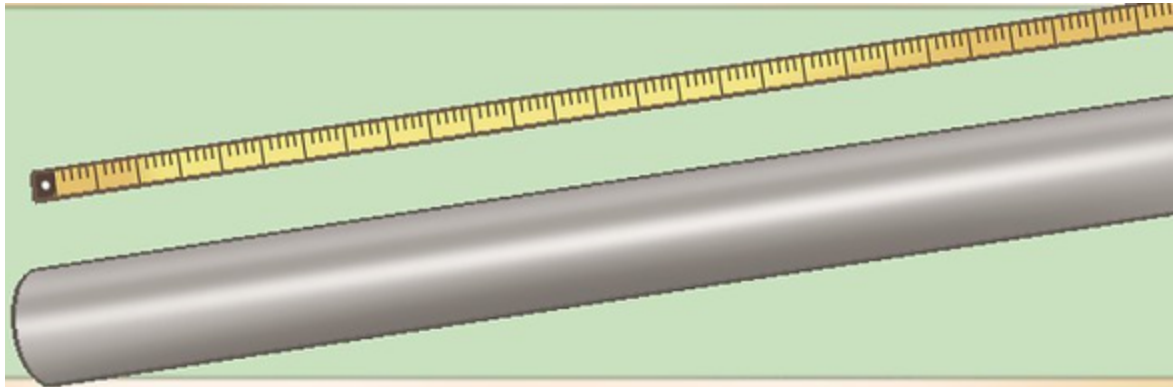

Figure 42: Measure the amount of conduit that you would need

Make appropriate marks in pencil wherever you think the bends should be, and measure the total length of the conduit that would be needed to finish the entire electrical conduit fittings. Now cut the length that you just measured with a tool called hacksaw. The cut ends are likely to have burrs which can be removed using a deburring tool or with pliers

**Step 4: Make the necessary bends**

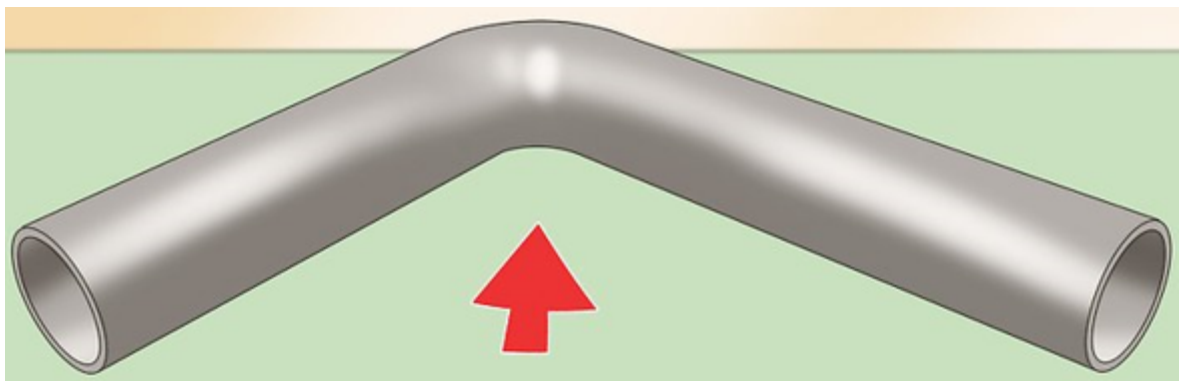

Figure 43: Step 4, Make the necessary bends

It is now time to make bends that you had marked on the pipe in the previous step. Owing to the easy flexibility of EMT, this should not be very difficult. Conduit benders come in handy for doing this bending.

**Step 5: Attach fittings to the wall**

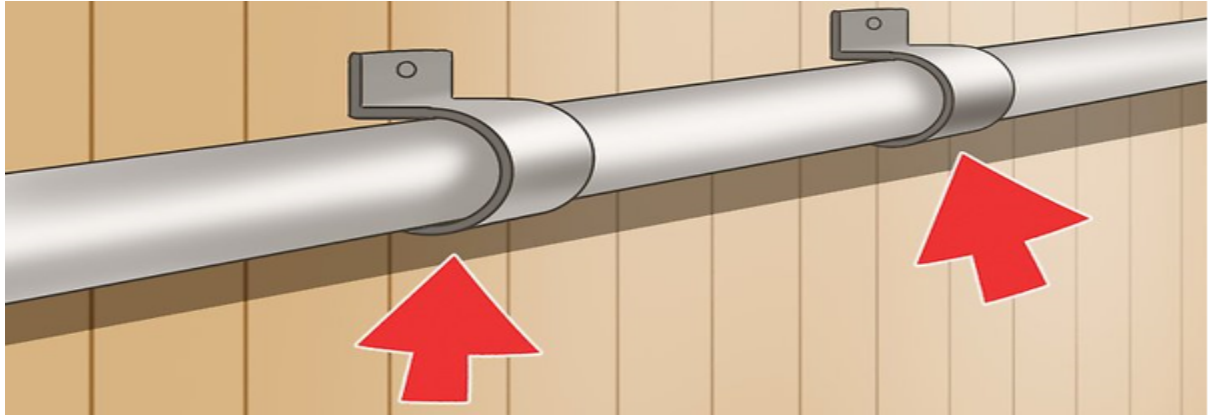

Figure 44: Step 5, Attach fittings to the Wall

You can use screws and straps with either single or double holes, available at electrical surplus shops, to attach electrical conduit fittings to the wall.

**Step 6: Tape the ends and put the wires in place**

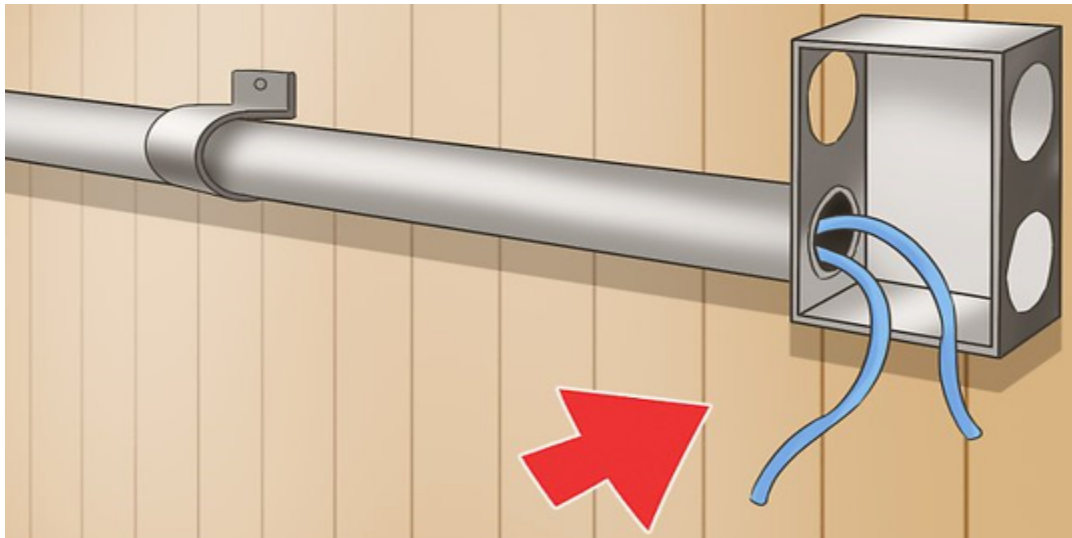

Figure 45: Step 6, Tape the end and put the wires in place

Use a widely available fish tape and run it through the entire route of the conduit fittings you just installed. Fix together the ends along with the electrical wires with the same fish tape. Give a finishing touch by pulling all the wire in the pipe in their right place.

### **Installation of PVC mini trunk**

- i. Install PVC boxes, then measure and mark the conduit for a cut. Cut with a backsaw and miter box, a hacksaw, or a circular saw equipped with a plywood blade.
- ii. Use alignment marks to ensure that the pieces face in the correct direction. Apply PVC primer (if needed) and cement to the outside of the conduit and to the inside of the fitting.
- iii. Immediately push the conduit into the fitting, twisting slightly to align the marks. Hold the pieces together for about 10 seconds; wipe away excess cement.

### **Step 1: Install Raceway Starter Box**



Figure 46: Step, Install Raceway Starter Box

Turn off the power and test to make sure it is off. Take the cover off an outlet and pull out the receptacle. Screw a raceway starter box, which has a large opening in the back, over the box in the wall.

### **Step 2: Align and Measure Channel**





Position a flat elbow onto the end of the raceway channel and hold it over a stud. Have someone help you hold the channel in place, and level it. Mark where to cut the channel — when installed the channel extends into the box by about 3/8 inch. Cut the channel with a hacksaw.

### Step 3: Attach Channel Clips



Position the channel temporarily in place. Level it and trace along it. Find the studs with a stud finder and drill pilot holes into them for screws that hold the channel clips in place. Attach the clips.

#### **Step 4: Install Channel to Elbow**



Reposition the flat elbow. Tap the channel gently with a rubber mallet to snap it into place. Screw the elbow to the wall.

#### **Step 5: Attach Second Channel**



Cut a second length of channel, attach it with clips, and tap it into place with a rubber mallet.

### Step 6: Fixture Box



Attach a fixture box.

### Step 7: Thread Wires



Fish wires through the channel and attach the covers over the elbow.



## Step 8: Hang Fixture



Hang the fixture and connect it to the outlet. Connect the wiring at the original receptacle.

### Storage of tools and equipment

- i. Have a designated place for each kind of tools.
- ii. Label the storage cabinet or place correctly for immediate finding.
- iii. Store them near the point of use.
- iv. Wash and dry properly before storing.
- v. Store knives properly when not in use with sharp edge down.

### Learning Activities

1. Draw the wiring diagram and install the circuit using PVC conduits

### Self-Assessment

1. A scale drawing showing the position of equipment by graphical symbols' is a description of a:
  - A. Block diagram
  - B. Layout diagram
  - C. Wiring diagram
  - D. Circuit diagram.
2. The recommended voltage for portable hand tools on construction sites is:
  - A. 50 V
  - B. 110 V



- C. 230 V
- D. 400 V

### **Tools, Equipment and Materials**

- i. Drill
- ii. Screwdriver
- iii. Spirit Level
- iv. Rubber mallet
- v. Strippers
- vi. Side cutters
- vii. Hacksaw
- viii. Lineman's pliers
- ix. Raceway components
- x. Wire nuts
- xi. Electrician's tape
- xii. Screw

### **References**

[www.doityourself.com](http://www.doityourself.com) > [stry](#) > [taking-care-of-electric-tools](#)

### **Model Answers to Self-Assessment questions**

- 1. **D**
- 2. **C**

## **1.4. Install Wire Ways, Trunking and Cable Trays**

### **Introduction**

In this context the learner should be able to explain and install different types of trunking and cable trays, also explain the procedures for installing of wire ways, trunkings and cable trays.

### **Performance Standard**

- i. Steel Trunking
- ii. Types and Sizes of Steel Trunking
- iii. Types of Support

### **Information Sheet**

### **Steel Trunking**

- i. A trunking is an enclosure that provides for the protection of cables. It is normally square or rectangular in cross section, and has a removable lid.
- ii. A trunking system offers great flexibility when used in conjunction with conduit systems. Trunking forms the backbone or framework of an installation. Conduits run from the trunking to accessory outlet boxes.
- iii. When an alteration or extension is required to an installation it is easy to drill a hole in the side of the trunking and run a conduit to the new accessory point. New wiring can then be drawn through the new conduit and the existing trunking to the supply point.

### Types and Sizes of Steel Trunking

There are a number of types of steel trunking such as: -

- i. Lighting Trunking
- ii. Cable trunking
- iii. Multi-Compartment trunking
- iv. Bus-bar Trunking

### Typical surface finishes.

- i. Hot dipped galvanized coating
- ii. Grey enamel on zinc coating
- iii. Silver enamel on zinc coating
- iv. Stainless steel

### Standard Sizes of Trunking

- |      |               |               |
|------|---------------|---------------|
| i.   | 50mm x 50mm   | 150mm x 75mm  |
| ii.  | 75mm x 50mm   | 150mm x 100mm |
| iii. | 75mm x 75mm   | 150mm x 150mm |
| iv.  | 100mm x 50mm  | 200mm x 100mm |
| v.   | 100mm x 75mm  | 225mm x 150mm |
| vi.  | 100mm x 50mm  | 250mm x 150mm |
| vii. | 100mm x 100mm | 300mm x 250mm |

Trunking is generally supplied in 3 metre lengths. Lighting trunking is often supplied in 5 metre lengths. Other lengths are available on request.

### Lighting Trunking

Steel trunking may be used to install luminaires. This type has quick fit drive-in couplings, which allow for fast, easy installation of long runs. The trunking is installed with the opening downwards as shown in Figure 1.



Trunking



Drive-in coupling

Figure 47: Light Trunking

A range of fittings is available to accommodate changes in direction, tees and intersections. These are bolted in position using at least two bolts depending on trunking size.



Flat Bend



Tee

Cable retainers are used to prevent the cables falling out of the trunking. Special attachments are used to fix the luminaires to the trunking and also to allow the cables enter for connection.



Cable Retainer



Attachment

Suspension brackets are used to suspend the trunking at the required height below the ceiling. End caps and either steel or plastic lids are installed to complete the enclosure. The lid is simply clipped into position.



Suspension Bracket

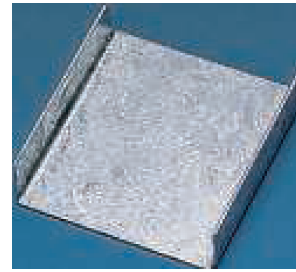

End Cap

### Cable Trunking

Standard cable trunking is similar in design to lighting trunking. The lid in this case is held in place with turnbuckles. A quarter turn of a large flat screwdriver will either fasten or loosen the turnbuckle.



Figure 48: Cable Trunking

A range of fittings is available to accommodate changes in direction, tees, intersections and to couple lengths together. These are bolted in position using at least two bolts depending on trunking size.



Flat Bend



Internal Bend



External Bend

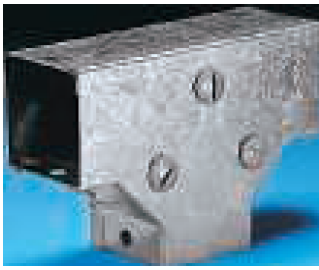

Tee

45° Bend

Coupling

Changes in trunking size are simply made by using reducers. Cables are easily kept in place in the trunking with cable retainers. End caps are used to complete the enclosure.



Reducer

Cable Retainer

End Cap

### **Multi-Compartment trunking**

The increasing use of electronics and differing voltage levels in industrial installations has necessitated the use of multi-compartment trunking, which is designed to segregate (separate) the various voltages and services.

Segregation of this nature is a requirement of the ETCI Rules. For example, it prevents an extra low voltage system, coming into contact with a low voltage system even in the event of a fault. It shows a typical section of multi-compartment trunking.

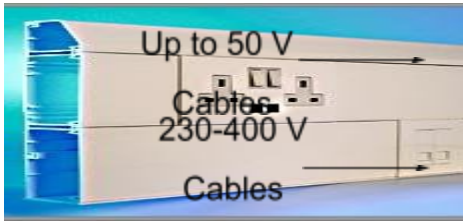

Figure 49: Multi-Compartment trunking

### Areas of Application

- i. Steel trunking systems are used in commercial and industrial premises.
- ii. Lighting trunking is generally used to supply and support fluorescent fittings, which illuminate large floor areas.
- iii. Cable trunking is installed at a suitable height around the walls of the building. Conduit drops are then used to supply outlet points.
- iv. Multi-compartment trunking is used where different electrical services are required in close proximity to each other. It is ideal in large offices and classrooms. Here it may be used to accommodate cables for supplying equipment at 230 Volts, plus data cables for computers, printers etc. These supplies must be segregated from each other.

### Types of Support

- i. Trunking should be secured by round-headed screws or bolts. This prevents damage to cables during installations.
- ii. In industrial installations, trunking may be run overhead, supported at intervals by the lower members of the roof trusses. It may be suspended from or fastened directly to right angle brackets. It may also be fixed directly to a wall surface.

### A number of fixings, which may be used to support trunking.



Beam Clamp

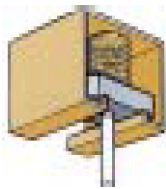

Vertical Flange Hangers

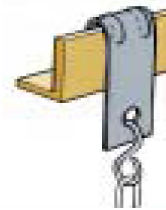

Channel Spring Nut

A run of trunking supported by suspension brackets. The threaded rod also allows for final height adjustment.



## Spacing of Supports

There are so many variables such as: - size of trunking, size and number of cables to be installed, type and strength of support available. However, the following table lists the maximum distances between supports for steel trunking.

Maximum Support Spacing for Steel Trunking		
Trunking Size	Horizontal	Vertical
50 x 50	1.75	2.0
75 x 50	3.0	3.0
Larger Sizes	3.0	3.0

Table 4: The Maximum distance between supports for steel trunking

## Cable Capacity and Space Factor

- i. Trunking is primarily intended for the installation of PVC insulated cables.
- ii. The maximum number of cables that can be installed in a trunking system is based on only 45% of the available space being occupied. This does not mean that the trunking should appear to be less than half full of cable. Remember that all the unoccupied space in between the cables is included in the calculation.
- iii. The main reason for limiting the number of cables to this level is to eliminate problems associated with an excessive buildup of heat inside the trunking. If too many cables are installed the cable insulation will suffer damage due to overheating. There is also the possibility of fire risk.
- iv. The ETCI Rules provides a handy guide to aid the calculation of the cable capacity of trunking. It allows for a mixture of all the common cable sizes up to 10 mm<sup>2</sup>. Other cable

sizes have to be accounted for on an individual basis. Remember that the overall cable CSA must be used in the calculation (not the CSA of the conductor alone).

- v. If multi-core cables are to be installed in trunking the 45% space factor still applies, except in the case of one multi-core cable only.

### Fabrication and Installation of Tees and Bends

Tee and bends may be fabricated where required in lengths of trunking.

This may be necessary or simply more convenient, particularly if the required bend or set is non-standard.

It takes more time to fabricate tees or bends than to bolt on manufactured accessories.

Note-: It is recommended that a 32 TPI hacksaw blade be used for cutting steel trunking.

### Forming a Tee Joint

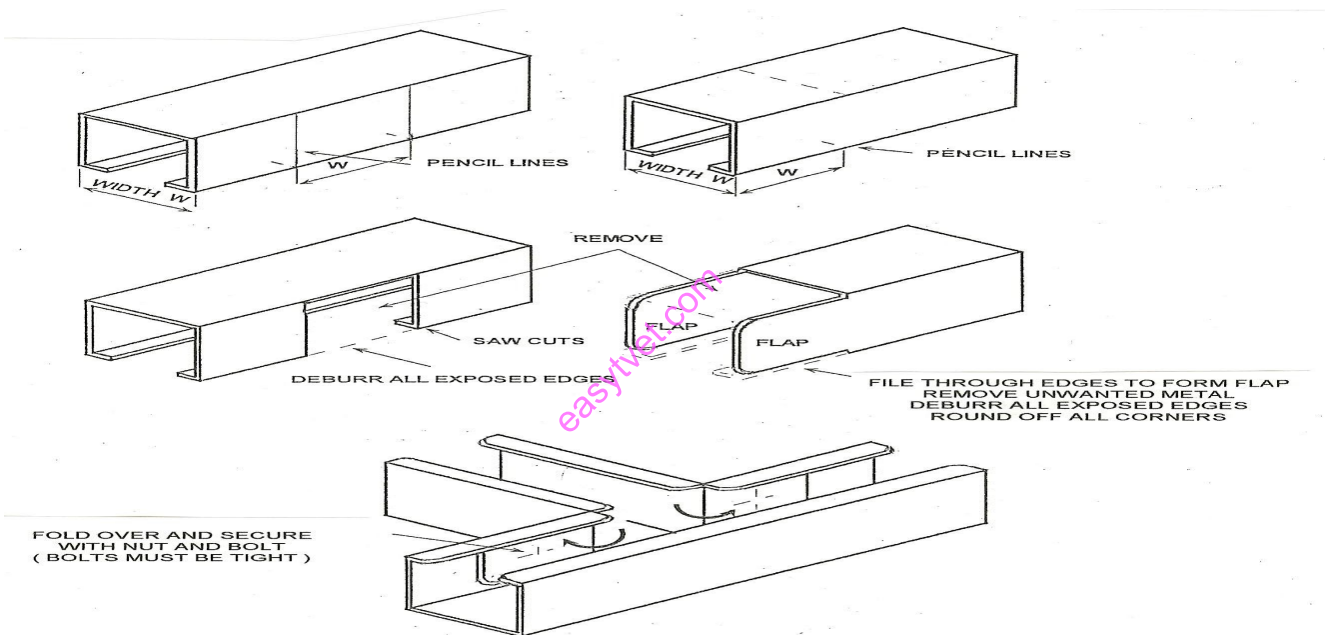

Figure 50: Forming a T-Joint

### Forming an Internal Bend



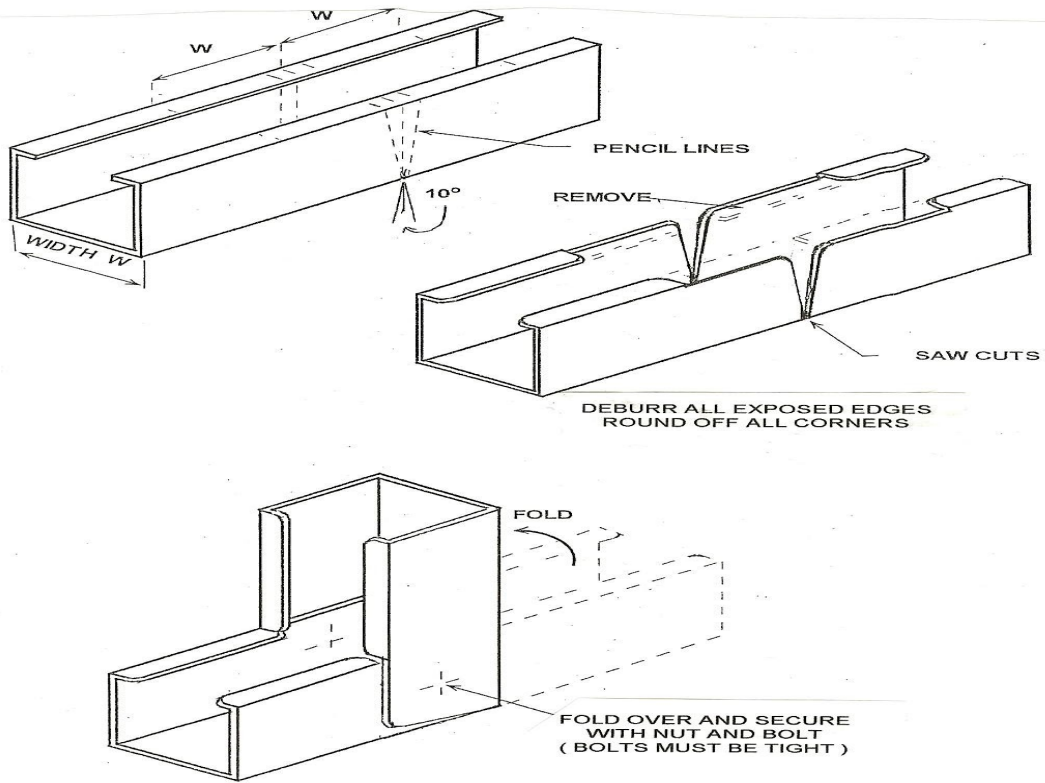
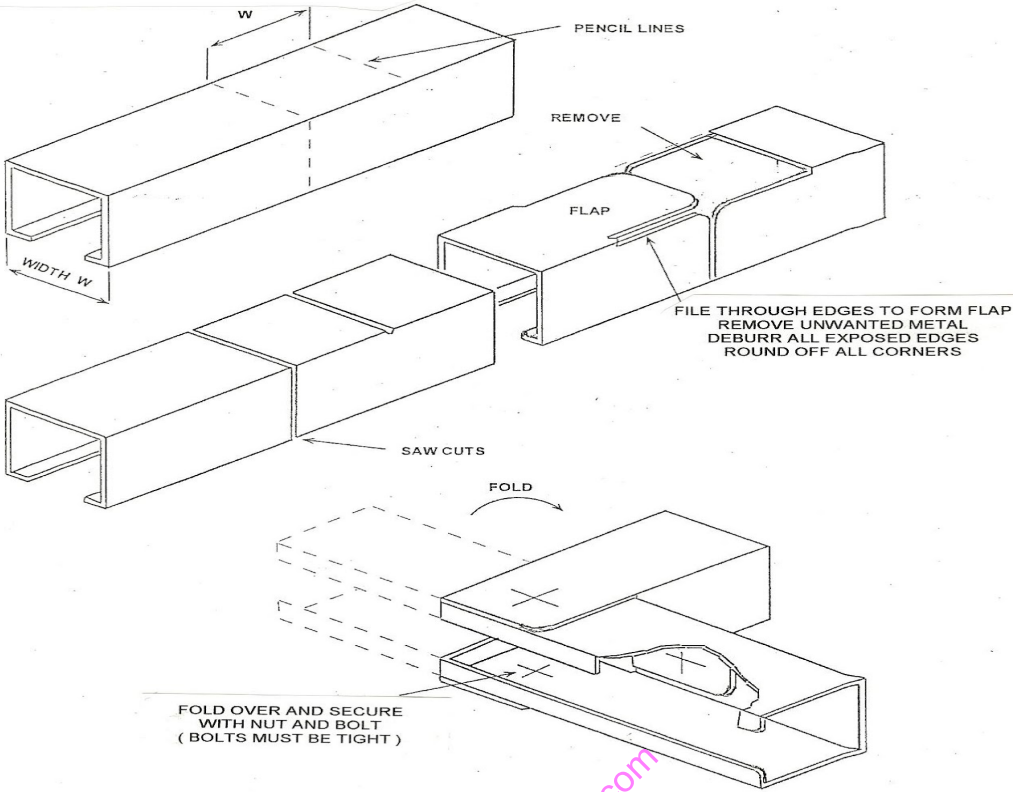

Figure 51: Forming an Internal Bend

# Forming an External Bend



easyvet.com

## Forming a Flat Bend

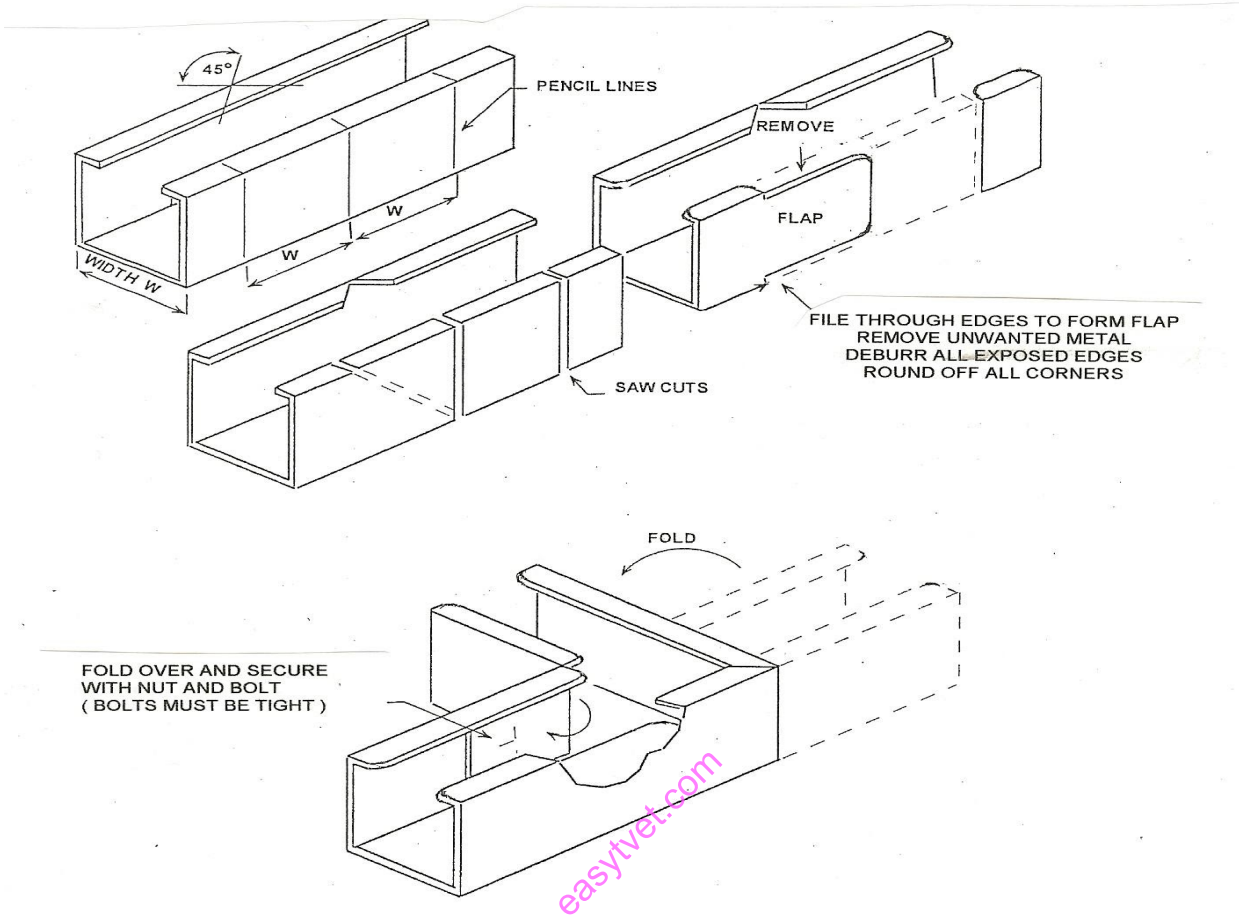

## Earthing of Steel Trunking

A trunking installation must be earthed. Earth continuity is ensured by the proper tightening of all bolts used throughout the system. Some manufactures recommend that earth continuity be completed by fixing a copper or aluminium strap across all joints. It is more important that all the bolts involved in the system are tightened. It is not unusual to find that copper or aluminium straps are used, but are left loose, resulting in poor earth continuity.



## Copper Earth Strap

### Learning Activities

1. Discussion on how to make a hot bending of PVC conduit
2. Using PVC conduit make the following off sets
  - i. 45°
  - ii. 30°
  - iii. 90° bend using steel conduit.

### Self-Assessment

1. What are the Advantages of PVC Conduit? (6marks)
2. What are the types of conduit used in electrical installation work? (4marks)

### Tools, Equipment and Materials

- i. Drill
- ii. Screwdriver
- iii. Level
- iv. Rubber mallet
- v. Strippers
- vi. Side cutters
- vii. Hacksaw
- viii. Lineman's pliers
- ix. Raceway components
- x. Wire nuts
- xi. Electrician's tape
- xii. Screws

### References

<https://www.electricveda.com/building-services/method-statement-for-installation-of-cable-tray-o>

### Model Answers to Self-Assessment

1. Advantages of PVC Conduit? (6marks)
  - i. Lightweight and easy to handle
  - ii. Easy to cut and deburr
  - iii. Simple to form and bend
  - iv. Does not require painting
  - v. Minimal condensation due to low thermal conductivity in wall of conduit.
  - vi. Speed of installation

2. Types of conduit used in electrical installation work? (4marks)

- i. PVC
- ii. Steel
- iii. Flexible
- iv. Stainless Steel

## 1.5. Install distribution board frames and auxiliary components

### Introduction

In this section the learner should learn on how to earth distribution board, conduct final checks for workmanship, conformity with instructions with job requirements.

### Performance Standard

- i. Distribution Boards
- ii. Method of earthing to main distribution board
- iii. Method of earthing to sub-distribution boards
- iv. Method of earthing to lighting and power outlet wiring
- v. Method of earthing to final ring sub-circuits
- vi. Method of earthing to electric loads and end units
- vii. Earthing System

### Information Sheet

#### Distribution Boards

Distribution boards (generally only one in residential premises) usually include the meter(s) and in some cases (notably where the supply utilities impose a TT earthing system and/or tariff conditions which limit the maximum permitted current consumption) an incoming supply differential circuit-breaker which includes an overcurrent trip. This circuit-breaker is freely accessible to the consumer.

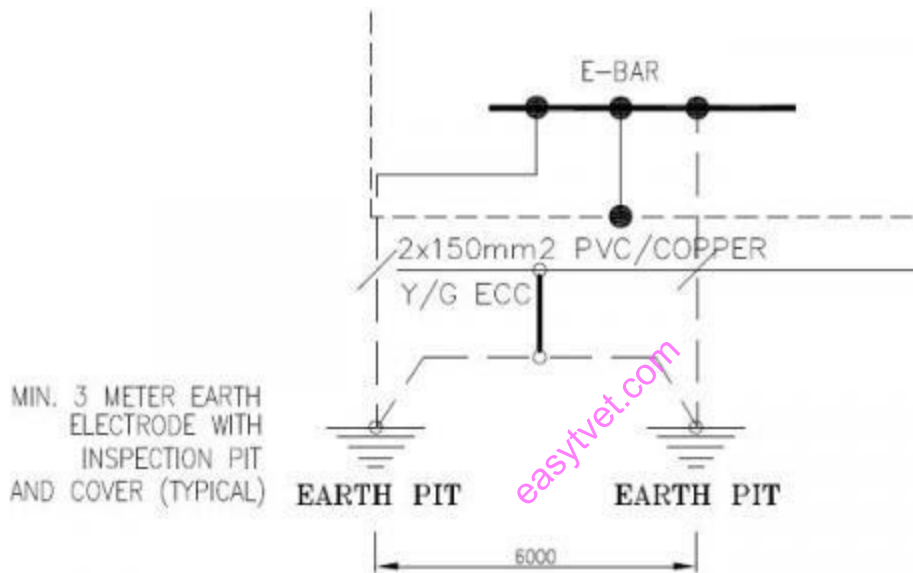

Figure 52: Residential DB

### Method of earthing to main distribution board

Main earthing bar is to be provided in main distribution room and connected to earth electrode by 2 insulated conductors (minimum 150 mm<sup>2</sup>) via testing joints.

Earthing bars of main distribution boards are to be connected, by insulated earthing conductor, directly to main earthing bar at main distribution room.



### Method of earthing to sub-distribution boards

Distribution, lighting and power panels are to be connected by protective conductors run together with incoming feeder cable, connecting, and earth terminals in panel boards with respective main distribution board earthing bar.

### Method of earthing to lighting and power outlet wiring

Socket outlets are to be earthed by protective conductor looped around with the branch circuit and connected to earth terminal within socket outlet box and to which socket outlet is to be connected

### Method of earthing to final ring sub-circuits

Protective conductor of every final ring sub –circuit is to be in form of a ring having both ends connected to earth terminal at origin in panel board

### **Method of earthing to electric loads and end units**

Lighting fixtures and other exposed conductive parts of electrical installations, such as, switches, heaters, air conditioning units etc. are to be connected by protective earth conductors to earthing terminals of respective panel boards

### **Earthing System**

- i. An earthing system or grounding system connects specific parts of an electric power system with the ground, typically the Earth's conductive surface, for safety and functional purposes.
- ii. The choice of earthing system can affect the safety and electromagnetic compatibility of the installation.
- iii. In addition to electric power systems, other systems may require grounding for safety or function. Tall structures may have lightning rods as part of a system to protect them from lightning strikes.
- iv. Telegraph lines may use the Earth as one conductor of a circuit, saving the cost of installation of a return wire over a long circuit. Radio antennas may require particular grounding for operation, as well as to control static electricity and provide lightning protection.

### **IEC terminology**

International standard IEC 60364 distinguishes three families of earthing arrangements, using the two-letter codes TN, TT, and IT.

The first letter indicates the connection between earth and the power-supply equipment (generator or transformer):

"T" — Direct connection of a point with earth.

"I" — No point is connected with earth except perhaps via a high impedance.

The second letter indicates the connection between earth or network and the electrical device being supplied:

"T" — Earth connection is by a local direct connection to earth, usually via a ground rod.

"N" — the earth connection is supplied by the electricity supply network, either separately to the neutral conductor (TN-S), combined with the neutral conductor (TN-C), or both (TN-C-S). These are discussed below.

## Types of TN networks

- i. In a TN earthing system, one of the points in the generator or transformer is connected with earth, usually the star point in a three-phase system. The body of the electrical device is connected with earth via this earth connection at the transformer. This arrangement is a current standard for residential and industrial electric systems.
- ii. The conductor that connects the exposed metallic parts of the consumer's electrical installation is called protective earth. The conductor that connects to the star point in a three-phase system, or that carries the return current in a single-phase system, is called neutral (N).
- iii. Three variants of TN systems are distinguished:

### TN-S

PE and N are separate conductors that are connected together only near the power source.

### TN-C

A combined PEN conductor fulfills the functions of both a PE and an N conductor. (on 230/400 V systems normally only used for distribution networks)

### TN-C-S

Part of the system uses a combined PEN conductor, which is at some point split up into separate PE and N lines. The combined PEN conductor typically occurs between the substation and the entry point into the building, and earth and neutral are separated in the service head.

In the UK, this system is also known as protective multiple earthing (PME), because of the practice of connecting the combined neutral-and-earth conductor via the shortest practicable route to local earth rods at the source and at intervals along the distribution networks to each premises, to provide both system earthing and equipment earthing at each of these locations.



<p>TN-S: separate protective earth (PE) and neutral (N) conductors from transformer to consuming device, which are not connected together at any point after the building distribution point.</p>	<p>TN-C: combined PE and N conductor all the way from the transformer to the consuming device.</p>	<p>TN-C-S earthing system: combined PEN conductor from transformer to building distribution point, but separate PE and N conductors in fixed indoor wiring and flexible power cords.</p>

It is possible to have both TN-S and TN-C-S supplies taken from the same transformer. For example, the sheaths on some underground cables corrode and stop providing good earth connections, and so homes where high resistance "bad earths" are found may be converted to TN-C-S.

This is only possible on a network when the neutral is suitably robust against failure, and conversion is not always possible. The PEN must be suitably reinforced against failure, as an open circuit PEN can impress full phase voltage on any exposed metal connected to the system earth downstream of the break.

The alternative is to provide a local earth and convert to TT. The main attraction of a TN network is the low impedance earth path allows easy automatic disconnection (ADS) on a high current circuit in the case of a line-to-PE short circuit as the same breaker or fuse will operate for either L-N or L-PE faults, and an RCD is not needed to detect earth faults.

### TT network

- i. In a TT (terre-terre) earthing system, the protective earth connection for the consumer is provided by a local earth electrode, (sometimes referred to as the Terra-Firma connection) and there is another independently installed at the generator.

- ii. There is no 'earth wire' between the two. The fault loop impedance is higher, and unless the electrode impedance is very low indeed, a TT installation should always have an RCD (GFCI) as its first isolator.
- iii. The big advantage of the TT earthing system is the reduced conducted interference from other users' connected equipment. TT has always been preferable for special applications like telecommunication sites that benefit from the interference-free earthing. Also, TT networks do not pose any serious risks in the case of a broken neutral. In addition, in locations where power is distributed overhead, earth conductors are not at risk of becoming live should any overhead distribution conductor be fractured by, say, a fallen tree or branch.
- iv. In pre-RCD era, the TT earthing system was unattractive for general use because of the difficulty of arranging reliable automatic disconnection (ADS) in the case of a line-to-PE short circuit (in comparison with TN systems, where the same breaker or fuse will operate for either L-N or L-PE faults). But as residual current devices mitigate this disadvantage, the TT earthing system has become much more attractive providing that all AC power circuits are RCD-protected. In some countries (such as the UK) TT is recommended for situations where a low impedance equipotential zone is impractical to maintain by bonding, where there is significant outdoor wiring, such as supplies to mobile homes and some agricultural settings, or where a high fault current could pose other dangers, such as at fuel depots or marinas.
- v. The TT earthing system is used throughout Japan, with RCD units in most industrial settings. This can impose added requirements on variable frequency drives and switched-mode power supplies which often have substantial filters passing high frequency noise to the ground conductor.

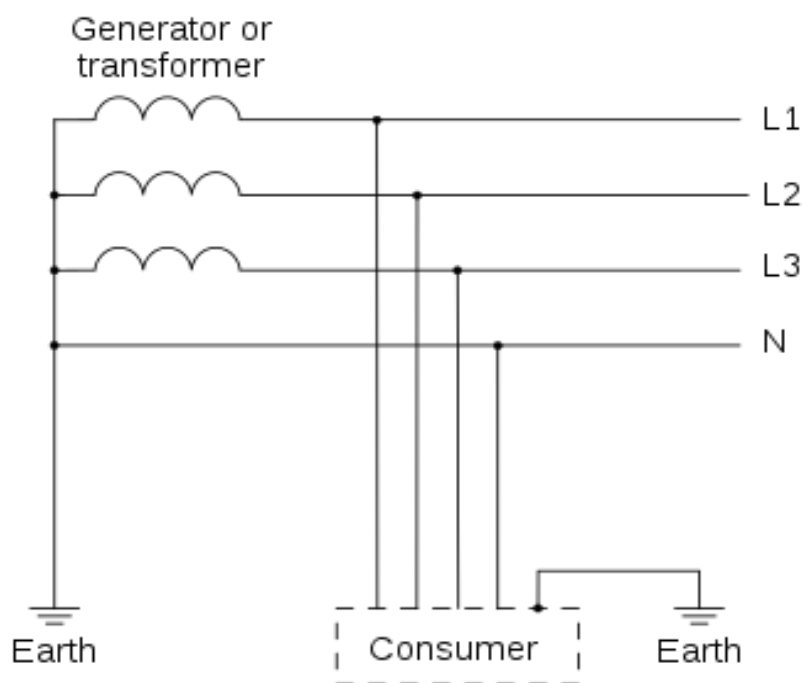

Figure 53: TT Network

### The TT (terre-terre) earthing system

#### IT network

In an IT network (isolé-terre), the electrical distribution system has no connection to earth at all, or it has only a high impedance connection.

	TT	IT	TN-S	TN-C	TN-C-S
Earth fault loop impedance	High	Highest	Low	Low	Low
RCD preferred?	Yes	N/A	Optional	No	Optional
Need earth electrode at site?	Yes	Yes	No	No	Optional
PE conductor cost	Low	Low	Highest	Least	High
Risk of broken neutral	No	No	High	Highest	High

Safety	Safe	Less Safe	Safest	Least Safe	Safe
Electromagnetic interference	Least	Least	Low	High	Low
Safety risks	High loop impedance (step voltages)	Double fault, overvoltage	Broken neutral	Broken neutral	Broken neutral
Advantages	Safe and reliable	Continuity of operation, cost	Safest	Cost	Safety and cost

Table 5: Summary of Networks

**Other terminologies**

While the national wiring regulations for buildings of many countries follow the IEC 60364 terminology, in North America (United States and Canada), the term "equipment grounding conductor" refers to equipment grounds and ground wires on branch circuits, and "grounding electrode conductor" is used for conductors bonding an earth ground rod (or similar) to a service panel. "Grounded conductor" is the system "neutral". Australian and New Zealand standards use a modified PME earthing system called Multiple Earthed Neutral (MEN). The neutral is grounded (earthed) at each consumer service point thereby effectively bringing the neutral potential difference to zero along the whole length of LV lines. In the UK and some Commonwealth countries, the term "PNE", meaning Phase-Neutral-Earth is used to indicate that three (or more for non-single-phase connections) conductors are used, i.e., PN-S.

**Resistance-earthed neutral**

A resistance earth system is used for mining in India as per Central Electricity Authority Regulations. Instead of a solid connection of neutral to earth, a neutral grounding resistor (NGR) is used to limit the current to ground to less than 750 mA. Due to the fault current restriction, it is safer for gassy mines. Since the earth leakage is restricted, leakage protection devices can be set to less than 750 mA. By comparison, in a solidly earthed system, earth fault current can be as much as the available short-circuit current.

The neutral earthing resistor is monitored to detect an interrupted ground connection and to shut off power if a fault is detected.<sup>[11]</sup>

**Earth leakage protection**

To avoid accidental shock, current sensing circuits are used at the source to isolate the power when leakage current exceed a certain limit. Residual-current devices (RCDs, RCCBs or GFCIs) are used for this purpose. Previously, an earth leakage circuit breaker is used. In industrial applications, earth leakage relays are used with separate core balanced current transformers.<sup>[12]</sup> This protection works in the range of milli-Amps and can be set from 30 mA to 3000 mA.

### **Earth connectivity check**

A separate pilot wire is run from distribution/ equipment supply system in addition to earth wire, to supervise the continuity of the wire. This is used in the trailing cables of mining machinery.<sup>[13]</sup> If the earth wire is broken, the pilot wire allows a sensing device at the source end to interrupt power to the machine. This type of circuit is a must for portable heavy electric equipment (like LHD (Load, Haul, Dump machine)) being used in underground mines.

### **Learning Activities**

In a TN earthing system, one of the points in the generator or transformer is connected with earth, usually the star point in a three-phase system. The body of the electrical device is connected with earth via this earth connection at the transformer. This arrangement is a current standard for residential and industrial electric systems

### **Self-Assessment**

1. What are the types of earthing methods to sub-distribution boards (3Marks)
2. What are the types of TN networks(7Marks)

### **Tools, Equipment and Materials**

- i. Multimeter
- ii. Earth rod
- iii. Screwdriver
- iv. Level
- v. Strippers
- vi. Side cutters
- vii. Hacksaw
- viii. Lineman's pliers
- ix. Raceway components
- x. Wire nuts
- xi. Electrician's tape
- xii. Screws
- xiii. Earthing cable

## References

[https://www.electrical-installation.org/enwiki/Residential\\_electrical\\_installation\\_-\\_Distribution\\_boards\\_components](https://www.electrical-installation.org/enwiki/Residential_electrical_installation_-_Distribution_boards_components)

## Model Answers to Self-Assessment Questions

### 1. Earthing methods to sub-distribution boards (3Marks)

Distribution, lighting and power panels are to be connected by protective conductors run together with incoming feeder cable, connecting, and earth terminals in panel boards with respective main distribution board earthing bar.

### Types of TN networks (7Marks)

- i. In a TN earthing system, one of the points in the generator or transformer is connected with earth, usually the star point in a three-phase system. The body of the electrical device is connected with earth via this earth connection at the transformer. This arrangement is a current standard for residential and industrial electric systems.
- ii. The conductor that connects the exposed metallic parts of the consumer's electrical installation is called protective earth. The conductor that connects to the star point in a three-phase system, or that carries the return current in a single-phase system, is called neutral (N).
- iii. Three variants of TN systems are distinguished:

TN-S

PE and N are separate conductors that are connected together only near the power source.

TN-C

A combined PEN conductor fulfills the functions of both a PE and an N conductor. (on 230/400 V systems normally only used for distribution networks)

TN-C-S

Part of the system uses a combined PEN conductor, which is at some point split up into separate PE and N lines. The combined PEN conductor typically occurs between the substation and the entry point into the building, and earth and neutral are separated in the service head.

## CHAPTER TWO: SINGLE PHASE ELECTRICAL INSTALLATION AND MAINTENANCE

**Unit Code:** ENG/LG/EI/CR/02/3/A

### **Relationship to Occupational Standards**

This unit addresses the Unit of Competency: Perform single phase electrical installation and maintenance

### **Introduction**

Current legal frameworks prescribed that all electrical wiring, testing, preventive and corrective maintenance shall be performed by Competent Persons. Therefore, the demand for Competent Persons is always there in tandem with the growth of construction industry. Hence, this course was especially being accredited to equip the trainees with relevant set of theoretical and practical skills for them in becoming Competent Persons that are recognized by Energy Commission once they are working on the fields near the future

### **Summary of Learning Outcomes**

1. Apply workplace safety
2. Interpret electrical drawings
3. Select correct types and sizes of cables
4. Install cables for lighting and power points
5. Install power intake point
6. Install consumer's control unit
7. Inspect and test the complete installation
8. Repair and maintain the installation

## **2.0. Interpret electrical drawings**

### **Introduction**

Electrical drawings are a formal and precise way of communicating information about the layout, the dimensions, features and precision of Electrical installations. Drawing is the universal language of engineering. To understand how to “read and interpret” a drawing it is necessary to be familiar with the standard conventions, rules, and symbols used on the various types of electrical drawings.

The purpose of this course is to prepare electrical personnel with the ability to read and understand the electrical diagrams, various standards and practices used for reading and Interpreting electrical drawings and schematics. Participants will be introduced to electrical symbols, one-line and three-line electrical schematics and their content, including basic layout

and legends. The course will help the attendees understand the symbols and the language used in electrical drawings in line with the international standards and practices, giving a detailed insight into the various types of electrical drawings used in the industry, their purpose and applications

### **Performance Standard**

- i. Identification of intake points and equipment
- ii. Identification of installation equipment and accessories e.g., switches, lamp holders
- iii. Identification of electrical symbols and abbreviations
- iv. Types of drawings
- v. Schematic/layout
- vi. Circuits and wiring

### **Information Sheet**

#### **Power Intake Point**

Identification of electrical wiring should be clear and accurate so that the risk of injury or damage is minimized. This article looks at requirements relating to the identification of conductors contained in Section 514 of BS 7671.

As required by Regulation 514.1.2, wiring should be arranged and/or marked so that it is readily identified for the purposes of inspection, testing, repair or alteration, and each circuit protective device (circuit breaker, fuse or RCD) should be arranged and identified so that the circuit protected may be easily recognized (Regulation 514.8.1).

Where it is impracticable to individually label protective devices, the protective devices may be identified by means of a durable chart or schedule fitted inside the cover of, or adjacent to, the consumer unit or distribution board. Regulation 514.9.1 requires that the form of information provided is legible and durable, and indicates:

- i. The type, and composition of each circuit (number of points served, number and size of conductors, type of wiring) and,
- ii. The method for providing shock protection (which protective measure (such as ADS) has been provided), and
- iii. The information necessary for the identification of each device performing the functions of protection, isolation and switching, and its location, and
- iv. Any circuit or equipment vulnerable to a typical test.

For a typical domestic premises and other simple types of installations, a copy of the combined 'Schedule of Circuit Details and Test Results', which forms part of a NICEIC Domestic Electrical Installation Certificate, fixed within or adjacent to the consumer unit



is likely to achieve compliance with Regulation 514.9.1. For more complex installations, however, more comprehensive information will be required.

### Requirements for conductors

Except where identification is not required, the cores of cables should be identified by colour, letters or numbers. Every core of a cable must be identifiable at its terminations and preferably throughout its length.

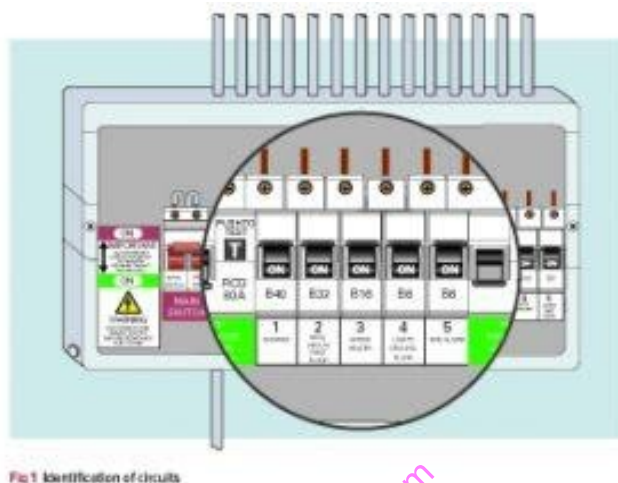

Figure 54; Identification of Circuits

### Omissions

Identification is not required for concentric conductors of cables, metal sheath or armored cables were used as a protective conductor, certain bare conductors where identification is not practicable, extraneous-conductive-parts used as a protective conductor and exposed-conductive-parts used as a protective conductor (Regulation 514.6.1).

### Identification of conductors by colour

For a single-phase installation, the line conductors should be identified by the colour brown and for a three-phase installation the line conductors should be identified by the colours of brown, black and grey. In either case, the neutral conductor must be identified by the colour blue (Regulation 514.4.1). A PEN conductor shall be identified in accordance with Regulation 514.4.3.

Where a conductor identified with the colour blue is used as a switch line, as is common for wiring in domestic premises, the correct identification must be applied at the terminations (both the switch and the ceiling rose). This is achieved, as shown in Fig 2.2, by sleeving the (blue)

switch line conductor with brown sleeving. In addition, the protective conductors should be identified using green-and-yellow sleeving only (Regulation 514.4.2).

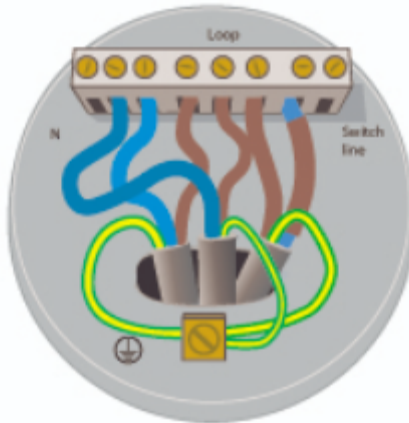

Figure 55: Identification of Switch lines and ceiling rose

### **Identification by lettering and/or numbering**

Where lettering and/or numbering is used it should be clear, legible and durable. In order to avoid confusion, unattached numerals 6 and 9 must be underlined (see Regulation 514.5.1). Where identification is by numbers, the number 0 (zero) is reserved for the neutral conductor (Regulation 514.5.4).

### **Bare conductors**

By the application of tape, sleeve or disc (or by painting) a bare conductor should be identified in accordance with Table 51 of BS 7671 (Regulation 514.4.6). Where a bare conductor or busbar is used as a protective conductor it must be identified, where necessary, by equal green-and yellow stripes, each not less than 15 mm and not more than 100 mm wide, close together, either throughout the length of the conductor or in each compartment and unit and at each accessible position.

### **Colours to previous versions of BS 7671:**

Except where there is no possibility of confusion, unambiguous marking must be provided at the interface between conductors identified in accordance with BS 7671 and wiring to previous versions of the Regulations. Where newly installed cables interface with conductors identified to a previous version (older colours), the guidance given in Appendix 7 of BS 7671 should be followed.

As shown in Fig 2.4, where an addition is made to an existing installation that is wired using the ‘older’ colours a ‘Caution’ notice in accordance with Regulation 514.14.1 must be provided at the appropriate consumer unit or distribution board.

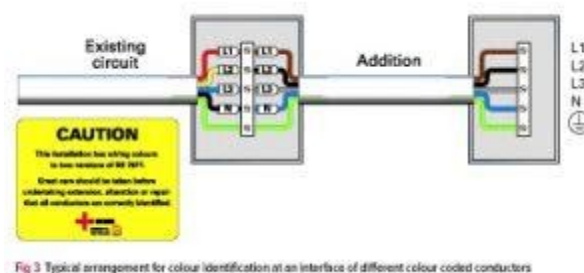

Fig. Typical arrangement for color identification at an interface of different color-coded conductors.

### Switchgear and control gear

Labels or other means of identification should be provided, where necessary, to indicate the purpose of switchgear and control gear.

### Other notices and labeling required

For safety reasons, BS 7671 requires a number of labels and notices to be provided, including the following:

- i. An RCD test notice should be provided at (or near) the origin of an installation which incorporates one or more residual current devices (Regulation 514.12.2).
- ii. An inspection recommendation label should be fitted on completion of installation work (including additions and alterations) and on each completion of periodic inspection, in a prominent position at or near the origin, giving the recommended date within which, the installation should be re-inspected (Regulation 514.12.1).
- iii. A voltage warning should be visible before gaining access to live parts in an enclosure where a nominal voltage exceeding 230 V to earth exists but would not normally be expected (Regulation 514.10.1).
- iv. Where a circuit is likely to have a high protective conductor current, information should be provided at the distribution board or consumer unit indicating the circuit(s) likely to have a high protective conductor current. The information should be positioned so it is visible to a person modifying or extending the circuit (Regulation 543.7.1.205).

## Point equipment

### Identification of installation equipment and accessories e.g., switches, lamp holders

#### Switch:

A switch is used to make or break the electric circuit. Or it is used to switch “ON or OFF” the electric supply. The switches may be one-way switch and two-way switch. The one-way switch is used to control single circuit or lamp, whereas the two-way switch is used to divert the flow of current to either of two directions. The two-way switch can also be used to control one lamp from two different places (As in case of stair case wiring).



Figure 56: Switch

#### Surface Switch:

The switches are mounted on wooden board, fixed over the surface of the wall. These switches are also known as “Tumbler switches”.

#### Flush/Piano type switch:

The switches are used where good appearance is required. The switches are fixed in flush with the wall and do not project out. These switches are also known as “Piano Type Switches”.

#### Bed switch:

As the name indicates, it is used to switch “ON or OFF” the light from the place, other than switch-board or from near the bed, while going to sleep or getting up. This switch is connected through flexible wire.



Figure 57: Bed Switch

[easytvvet.com](http://easytvvet.com)

**Rotary switch:** This switch is used to control different lamps from one place one by one or as selector switch, to select different voltage tapping of transformer in voltage stabilizer



Figure 58: Rotary Switch

**Push Button switch:**

These switches are used to control the electric bell and indicating lamps etc. When the push button is pressed, the circuit is completed and the bell or lamp is switched on. The supply to bell or lamp is switched off as the push button is released.



Figure 59: Push Button Switch

**Pull switch:** These switches are operated with a single pull of the cord, for the on and off position. These are also used in bedroom and bathroom. These switches are fixed near the ceiling and hence these are also known as “Ceiling Switches”.

**Intermediate switch:** This switch has four terminals and four different connection position. The main function of this switch is to control a lamp from three or more different places, along with ordinary two-way switch. Generally, this switch is used in double stair case wiring or corridor wiring. This switch is also known as four-way switch.

**Lamp Holder:** As the name indicates, a lamp holder is used to hold the lamp, and connect it electrically to supply terminals, required for lighting purposes. The lamp holders may be bayonet cap and screw type. Depending upon our requirement, these lamp holders are also manufactured in different designs

Some important types of lamp holders are detailed below: -

**Batten Lamp Holder:** These lamp holders may be of brass or Bakelite, with brass plunger. The holders are fixed on either on round block or wooden board with the help of wooden screws.



Figure 60:Batten Lamp Holder

**Pendant Lamp Holder:** This lamp holder is used to hang the lamp from ceiling rose, with flexible wire. Sometime these holders are provided with lampshades, to divert the upward light to down ward. These may be of brass or Bakelite, with brass plunger.



Figure 61:Pendant Holder

**Angle Lamp Holder:** The angle holder is used to focus the light at an angle and is fixed directly on wall or round block with the help of gutties and wooden screws. These may be of brass or Bakelite with brass plunger.



Figure 62: Angle Lamp Holder

**Swivel Lamp Holder:** These lamp holders are used for lighting of shop windows, show case etc. It consists of ball and socket joint fitted between back plate and lamp holder, for the purpose to move the light to a wide angle.





Figure 63: Swivel Lamp holder

**Bracket Lamp Holder:** These lamp holders are used to focus the light on the floor or at some angle, slightly away from the walls. Light shades can also be used for diverting all light on floor. Such lamps are provided with such fittings which make them water tight so that these can be used outside the houses or for street lighting. The bracket may be of wood, aluminum and brass. The lamp holder is simply a pendant holder made of brass or Bakelite.



Figure 64: Bracket Lamp Holder

## Fluorescent Lamp (Tube) Holder



Figure 65:Fluorescent Lamp (Tube) Holder

These are used to hold the fluorescent tube and pin type holders are generally used.

## Ceiling Rose

These are fixed on walls near the ceiling. Normally these are used to provide tapping to the pendent lamp holder, ceiling fan and fluorescent tube etc through the flexible wire.



Figure 66: Ceiling rose

## Socket

The sockets have insulated base with moulded base having three terminal sleeves. The two terminal sleeves having same cross-section are used to connect phase and neutral wire whereas the third having greater cross-section is used to connect with earth wire. These are made for 5 amps and 15 amps load. Two-pin sockets are also available, in which only phase and neutral wires are connected. These are available in 5-amp capacity.



Figure 67: Socket

### Plug

The plugs are also having moulded three pins of brass or any electrically conducting material. These are also made of 5 amp and 15-amp rating. These are used for taking power from socket.



Figure 68: Pin Switch

### Main Switch

As the name indicates that this switch is used to switch “on or off” the main supply. In other words these switches are used to control the whole supply for a house, office and machine. In single-phase circuit I.C.D.P. main switches are used, whereas in three-phase circuits I.C.T.P. main switches are used to control the supply. The main switches are of the following type: **a) I.C.D.P. Switch:** Iron Clad Double Pole main switch is used in single-phase supply circuits. These are available in 15 Amp, 30 Amp, 60 Amps and 100 amperes current rating.



Figure 69: Main Switch

In these switches, either two numbers of fuse links are provided or a fuse link and a neutral link is provided. The neutral wire is directly connected with the neutral link and phase wire is connected with the fuse link. Normally 15 Amp current rating main switches are made of plastic moulding instead of iron.

**I.C.T.P Switch:** Iron Clad Triple Pole main switches are used to control the three phase supply circuit. These are available in 15 Amp, 30 Amp, 60 Amp, 100 Amp, 150 Amp and 250 Amps current rating.



Figure 70: I.C.T.P Switch

Generally, these switches are also known as 3 phase 4 wires main switches. In these switches, three fuses and a neutral link is available. The neutral wire is directly connected with the neutral link and phase wires are connected with these fuse links.

### **Fuse**

It is the most common and important type of safety device used for domestic and commercial installations. These fuses are of kit-Kat type and are also known as cut-out.



Figure 71: Cut Out Fuse

These cut-outs are made of porcelain in current rating of 15 to 300 amperes. The material used as a fuse wire is tin, lead, silver, antimony, copper and aluminum etc. Copper or lead, tin alloy is mostly used in ordinary fuse wire.

### **Miniature Circuit Breaker (M.C.B.)**

A miniature circuit breaker is an electro-mechanical safety device which operate and disconnect the circuit supply, when the current drawn from the circuit increases to a pre-determined value. These are used in lieu of fuses and can be fitted in consumer's distribution board. An MCB will normally operates at 1.25 times its rated current value. It can be reset, by simply lifting its operational knob, whereas the fuse has to replace its fuse wire. Hence the miniature circuit breakers are replacing the rewirable fuses now a day.



Figure 72: Miniature Circuit Braker

### Identification of electrical symbols and abbreviations

**Symbols** are a shorthand way of showing the locations, types, and sizes or ratings of **electrical** wiring and equipment, and the interrelationships between these items. It should be emphasized that **drawings** need to be supplemented with specifications in order to establish the details of the **electrical** systems.

# TYPICAL ELECTRICAL DRAWING SYMBOLS AND CONVENTIONS

## ELECTRICAL SYMBOLS

CONTACTS, SWITCHES, CONTACTORS AND RELAYS	
SYMBOL	DESCRIPTION
	Relay contact - Shown with relay in de-energized or in reset position. (Show relay coil designation near contact.)
	Timing Relay Contact - TDC indicates contact closes at end of timing period. TDO contact opens at end of timing period.
	Coil - Relay, contactors, circuit breaker, solenoid etc. (Show device designation, XI)
	Coil - Timing Relay - TDDO indicates timing period starts when coil is de-energized. TDDO indicates timing period starts when coil is energized.
	Latching Relay or Mechanically-Held Contactor O=operate; R=reset; TC=trip coil; CC=closing coil. (Coils may be separated on diagram)
	Knife Switch, general. (if shown closed, terminals must be added.)
	Switch - General, single pole, single throw.
	Switch - One pole of multi-pole switch shown. Other poles shown elsewhere.
	Pushbutton - Momentary or spring return. Single Circuit (make)
	Pushbutton - Momentary or spring return. Single Circuit (break)
	Pushbutton - Momentary or spring return. Two Circuit
	Pushbutton - Maintained, two circuit
	Pushbutton - Maintained, single circuit
	Selector Switch - Two position, maintained (designate position shown; i.e. A=Auto; B=Hand)
	Selector Switch - Three position, SR indicates spring return from position so labeled. ("TRIP-(NORMAL)-CLOSE" position shown)
	Limit Switch - Normally open - Not applicable for Motor Operated Valves and Solenoid Valves.
	Limit Switch - Normally closed - Not applicable for Motor Operated Valves and Solenoid Valves.

Figure 73: Electrical Installation Drawing symbols

### Types of drawings

One of the best ways to communicate one's ideas is through some form of picture or drawing. This is especially true for the engineer. The purpose of this guide is to give you the basics of engineering sketching and drawing.

We hope you like the object in Figure 1, because you'll be seeing a lot of it. Before we get started on any technical drawings, let's get a good look at this strange block from several angles.

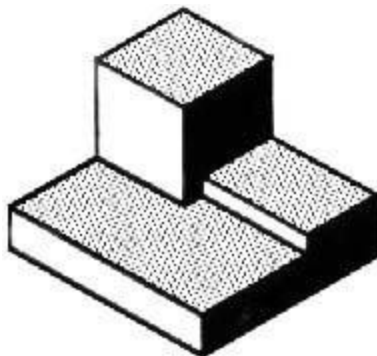

Figure 74: Machined Block

## Isometric Drawing

The representation of the object in figure 1.22 is called an isometric drawing. This is one of a family of three-dimensional views called pictorial drawings. In an isometric drawing, the object's vertical lines are drawn vertically, and the horizontal lines in the width and depth planes are shown at 30 degrees to the horizontal. When drawn under these guidelines, the lines parallel to these three axes are at their true (scale) lengths. Lines that are not parallel to these axes will not be of their true length.

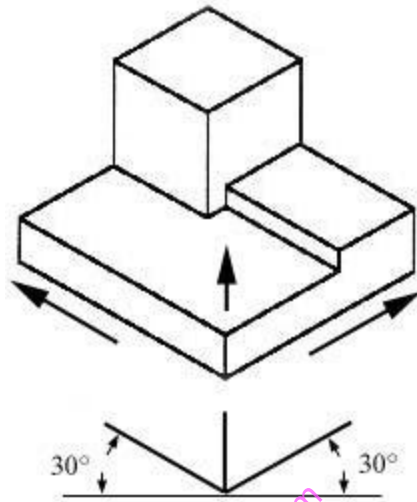

Figure 75: Isometric Drawing

Any engineering drawing should show everything: a complete understanding of the object should be possible from the drawing. If the isometric drawing can show all details and all dimensions on one drawing, it is ideal. One can pack a great deal of information into an isometric drawing. However, if the object in figure 2.22 had a hole on the back side, it would not be visible using a single isometric drawing. In order to get a more complete view of the object, an orthographic projection may be used.

## Orthographic or Multiview Drawing

Imagine that you have an object suspended by transparent threads inside a glass box, as in figure 2.23



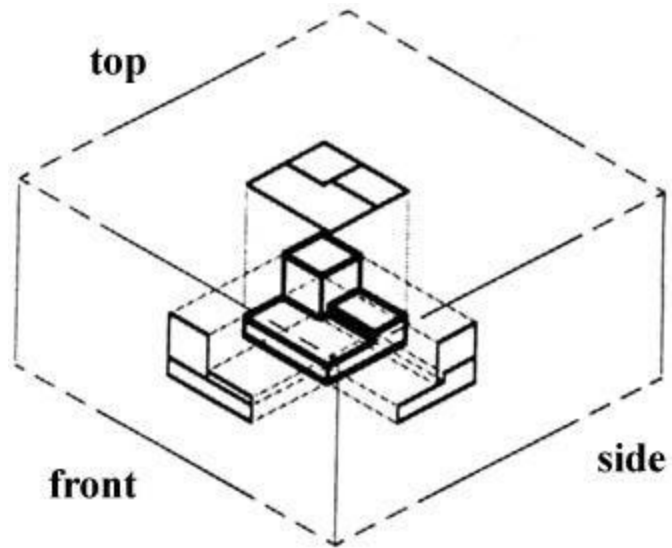

The block suspended in a glass box.

Then draw the object on each of three faces as seen from that direction. Unfold the box (figure 4) and you have the three views. We call this an "orthographic" or "multiview" drawing.

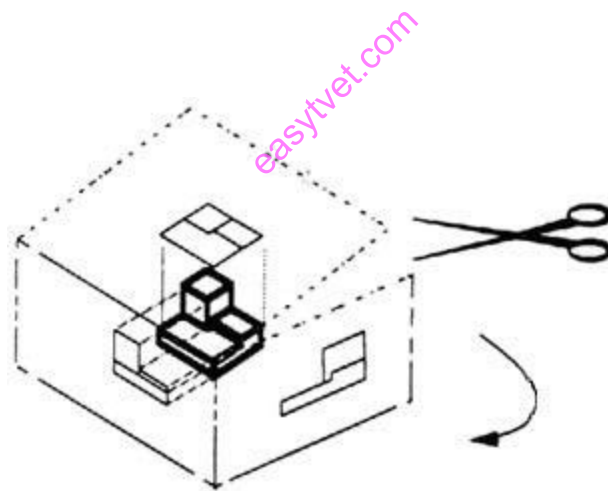

The creation of an orthographic Multiview drawing.

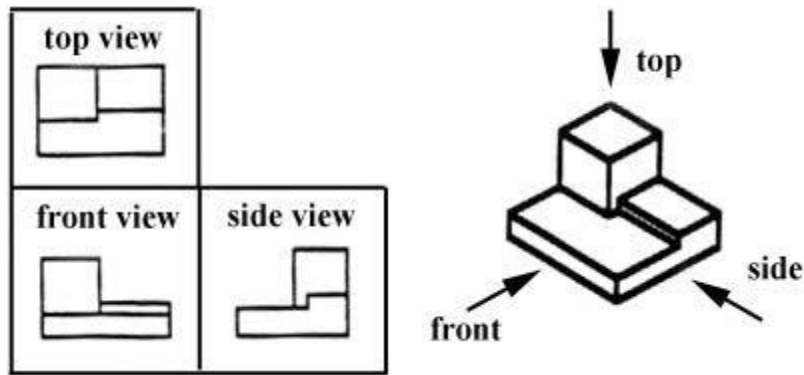

A Multiview drawing

Which views should one choose for a multiview drawing? The views that reveal every detail about the object. Three views are not always necessary; we need only as many views as are required to describe the object fully. For example, some objects need only two views, while others need four. The circular object in figure 6 requires only two views.

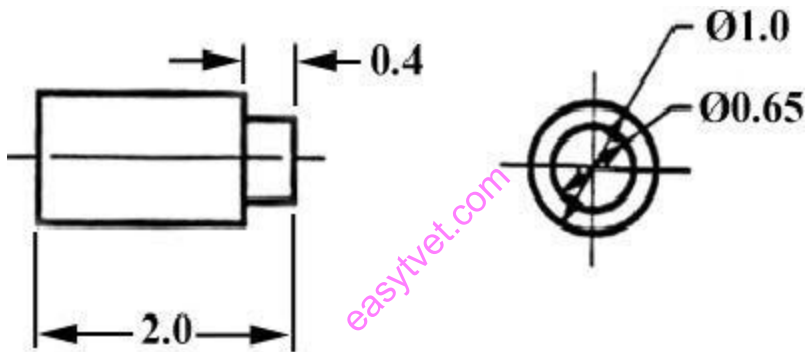

Two orthogonal views.

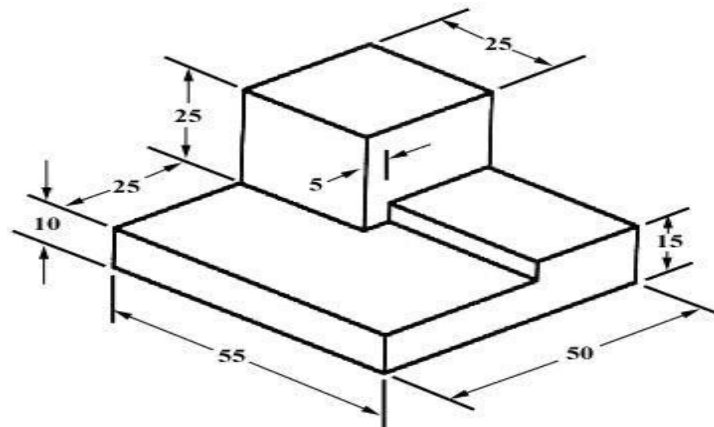

We have "dimensioned" the object in the isometric drawing in figure 2.27. As a general guideline to dimensioning, try to think that you would make an object and dimension it in the most useful way. Put in exactly as many dimensions as are necessary for the craftsperson to make it -no more, no less. Do not put in redundant dimensions. Not only will these clutter the drawing, but if "tolerances" or accuracy levels have been included, the redundant dimensions often lead to conflicts when the tolerance allowances can be added in different ways.

Repeatedly measuring from one point to another will lead to inaccuracies. It is often better to measure from one end to various points. This gives the dimensions a reference standard. It is helpful to choose the placement of the dimension in the order in which a machinist would create the part. This convention may take some experience.

### **Sectioning**

There are many times when the interior details of an object cannot be seen from the outside (figure 8).

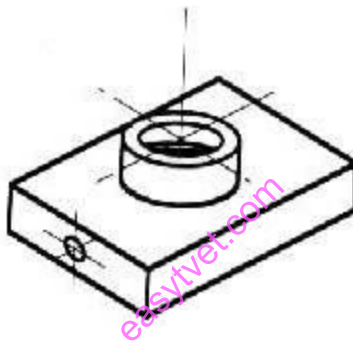

An isometric drawing without all details.

We can get around this by pretending to cut the object on a plane and showing the "sectional view". The sectional view is applicable to objects like engine blocks, where the interior details are intricate and would be very difficult to understand through the use of "hidden" lines (hidden lines are, by convention, dotted) on an orthographic or isometric drawing.

Imagine slicing the object in the middle (figure 9):

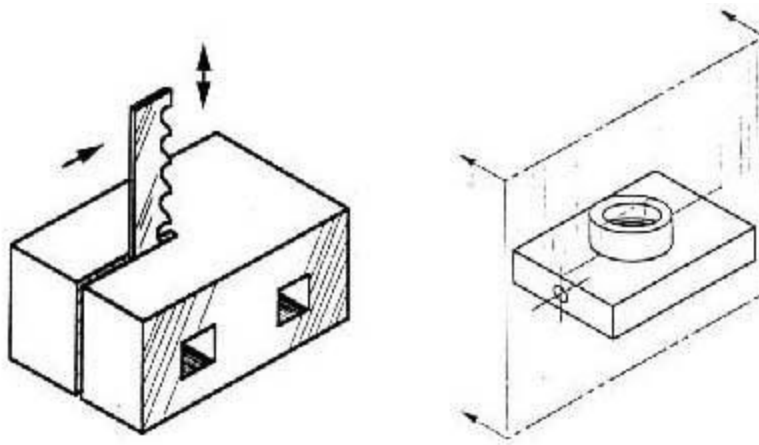

"Sectioning" an object.

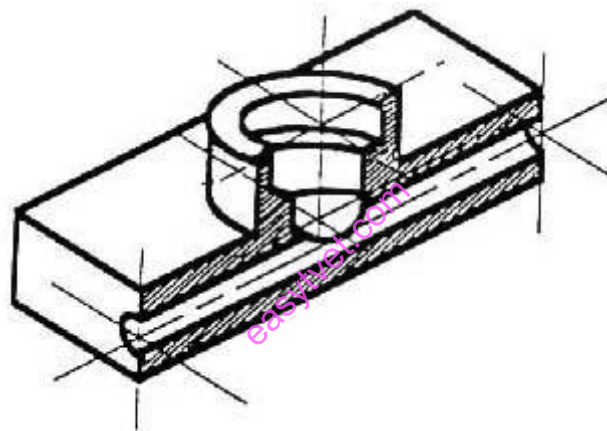

Sectioning the object in figure 2.28.

Take away the front half (figure 2.30) and what you have is a full section view (figure 2.31).

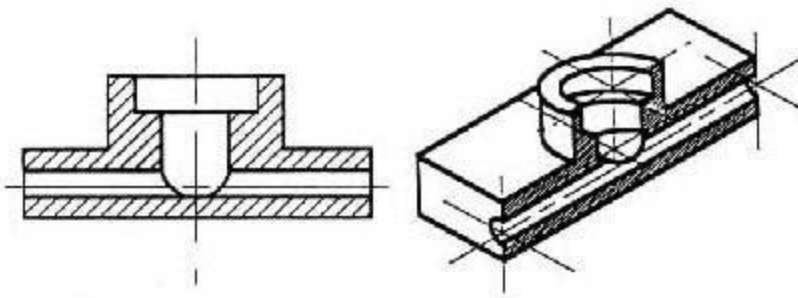

Sectioned isometric and orthogonal views.

The cross-section looks like figure 2.31 when it is viewed from straight ahead.

### "Assembly" Drawings

An isometric view of an "assembled" pillow-block bearing system is shown in figure 13. It corresponds closely to what you actually see when viewing the object from a particular angle. We cannot tell what the inside of the part looks like from this view.

We can also show isometric views of the pillow-block being taken apart or "disassembled" (figure 14). This allows you to see the inner components of the bearing system. Isometric drawings can show overall arrangement clearly, but not the details and the dimensions.

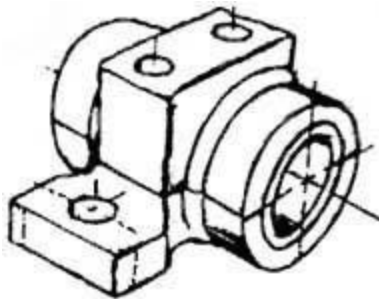

Pillow-block (Freehand sketch).

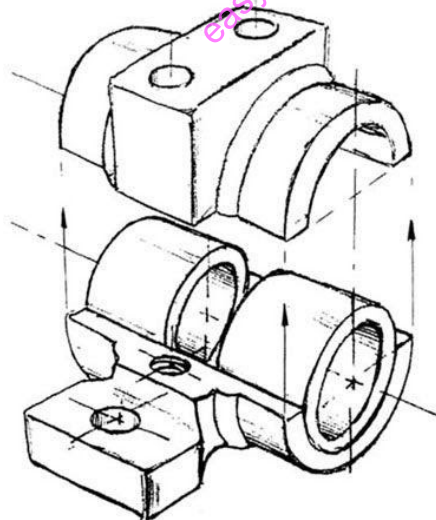

Disassembled Pillow-block.

### Cross-Sectional Views

A cross-sectional view portrays a cut-away portion of the object and is another way to show hidden components in a device.

Imagine a plane that cuts vertically through the center of the pillow block as shown in figure 15. Then imagine removing the material from the front of this plane, as shown in figure 2.35

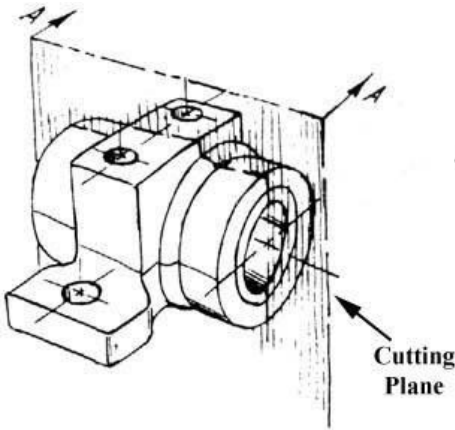

Pillow Block.

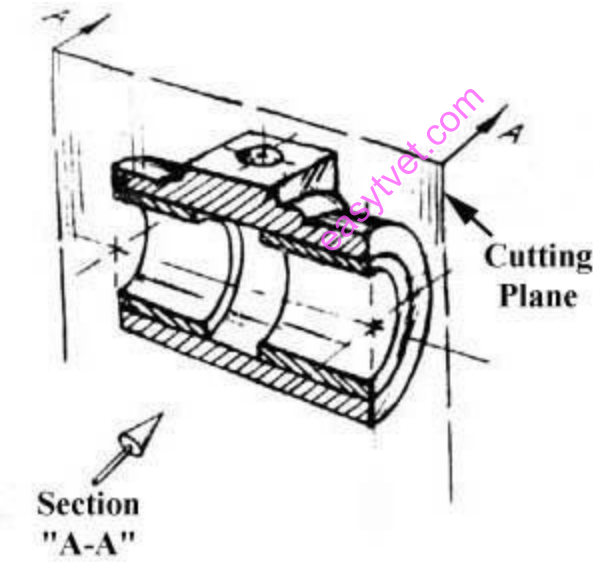

Pillow Block.

This is how the remaining rear section would look. Diagonal lines (cross-hatches) show regions where materials have been cut by the cutting plane.

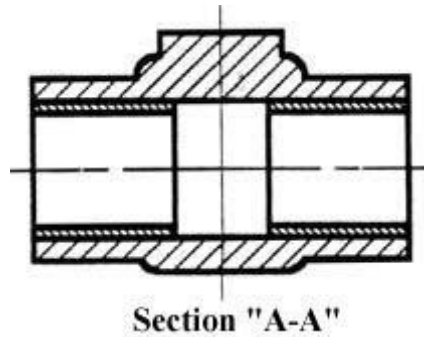

Section "A-A".

This cross-sectional view (section A-A, figure 2.36), one that is orthogonal to the viewing direction, shows the relationships of lengths and diameters better. These drawings are easier to make than isometric drawings. Seasoned engineers can interpret orthogonal drawings without needing an isometric drawing, but this takes a bit of practice.

The top "outside" view of the bearing is shown in figure 2.37. It is an orthogonal (perpendicular) projection. Notice the direction of the arrows for the "A-A" cutting plane.

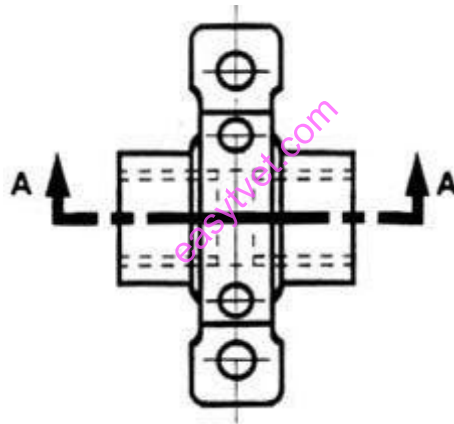

The top "outside" view of the bearing.

### Half-Sections

A half-section is a view of an object showing one-half of the view in section, as in figure 2.35 and 2.36

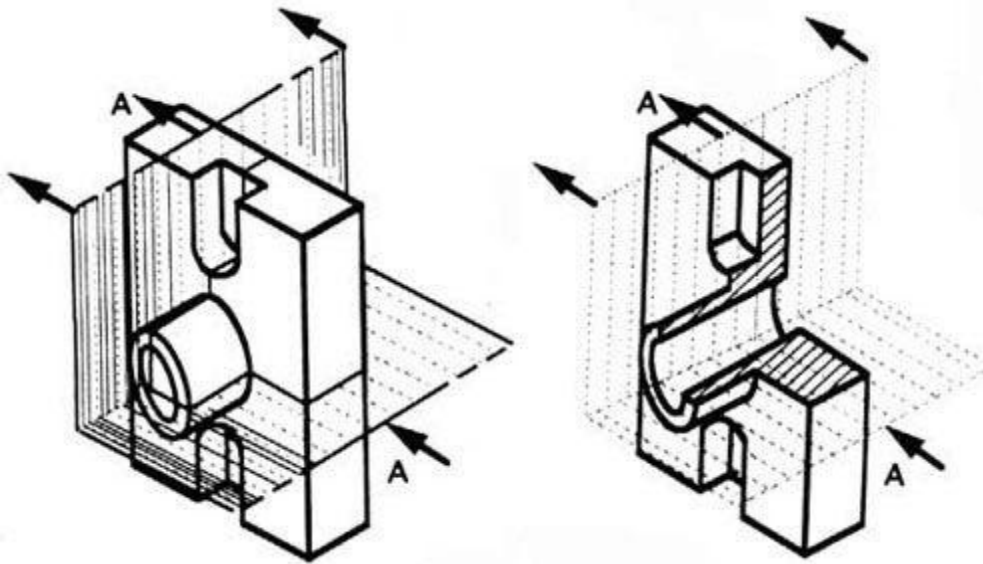

Full and sectioned isometric views.

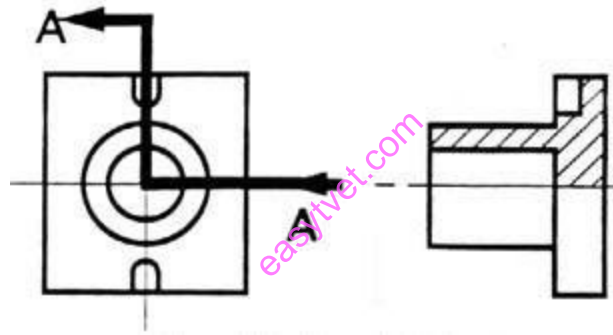

Front view and half section.

The diagonal lines on the section drawing are used to indicate the area that has been theoretically cut. These lines are called section lining or cross-hatching. The lines are thin and are usually drawn at a 45-degree angle to the major outline of the object. The spacing between lines should be uniform.

A second, rarer, use of cross-hatching is to indicate the material of the object. One form of cross-hatching may be used for cast iron, another for bronze, and so forth. More usually, the type of material is indicated elsewhere on the drawing, making the use of different types of cross-hatching unnecessary.



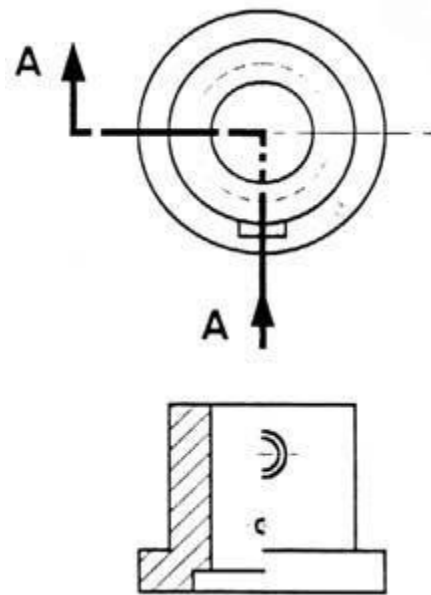

Half section without hidden lines.

Usually hidden (dotted) lines are not used on the cross-section unless they are needed for dimensioning purposes. Also, some hidden lines on the non-sectioned part of the drawings are not needed (figure 2.22) since they become redundant information and may clutter the drawing.

### Sectioning Objects with Holes, Ribs, Etc.

The cross-section on the right of figure 2.41 is technically correct. However, the convention in a drawing is to show the view on the left as the preferred method for sectioning this type of object.

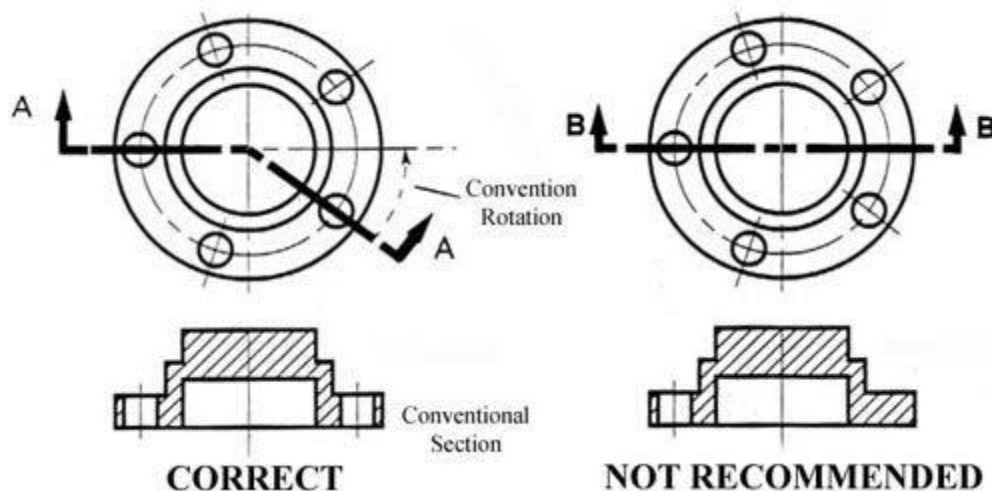

Cross section

## Dimensioning

The purpose of dimensioning is to provide a clear and complete description of an object. A complete set of dimensions will permit only one interpretation needed to construct the part. Dimensioning should follow these guidelines.

- i. Accuracy: correct values must be given.
- ii. Clearness: dimensions must be placed in appropriate positions.
- iii. Completeness: nothing must be left out, and nothing duplicated.
- iv. Readability: the appropriate line quality must be used for legibility.

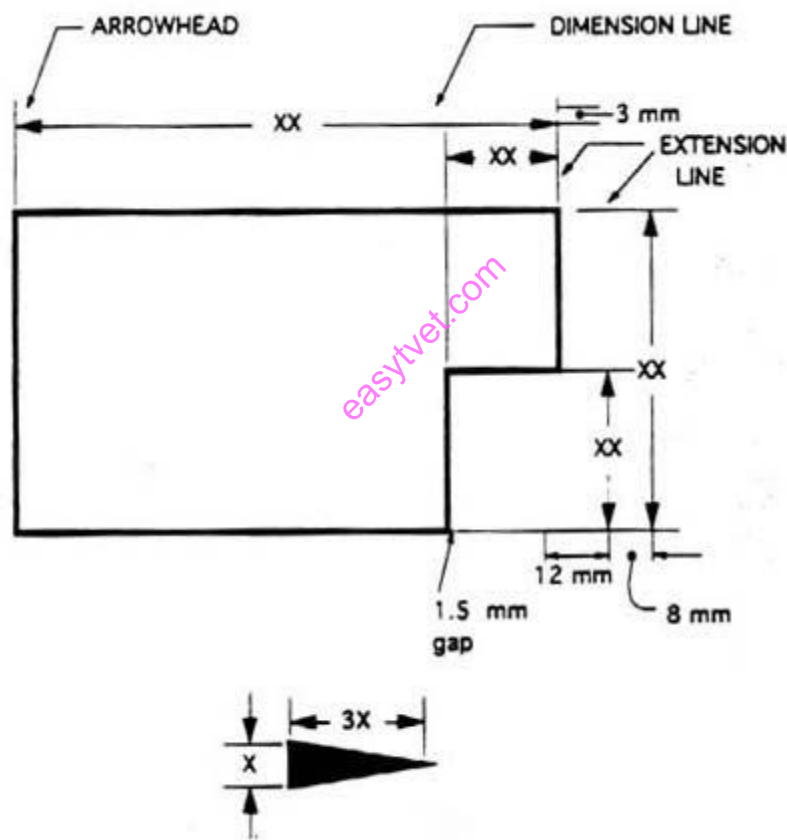

Dimensioned Drawing.

An **arrowhead** is approximately 3 mm long and 1 mm wide. That is, the length is roughly three times the width. An **extension line** extends a line on the object to the dimension line. The first-dimension line should be approximately 12 mm (0.6 in) from the object. Extension lines begin 1.5 mm from the object and extend 3 mm from the last dimension line.

A leader is a thin line used to connect a dimension with a particular area.

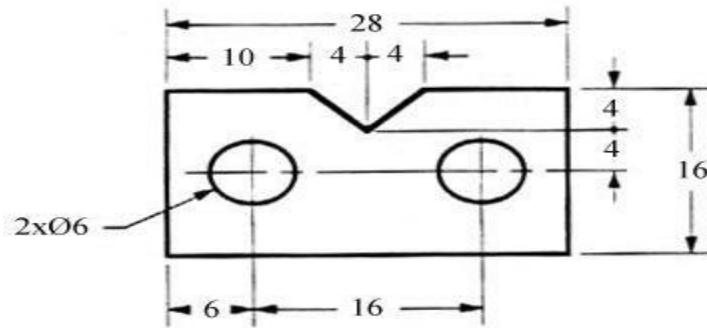

Drawing with a leader.

A leader may also be used to indicate a note or comment about a specific area. When there is limited space, a heavy black dot may be substituted for the arrows. Also in this drawing, two holes are identical, allowing the "2x" notation to be used and the dimension to point to only one of the circles.

### Where to Put Dimensions

The dimensions should be placed on the face that describes the feature most clearly.

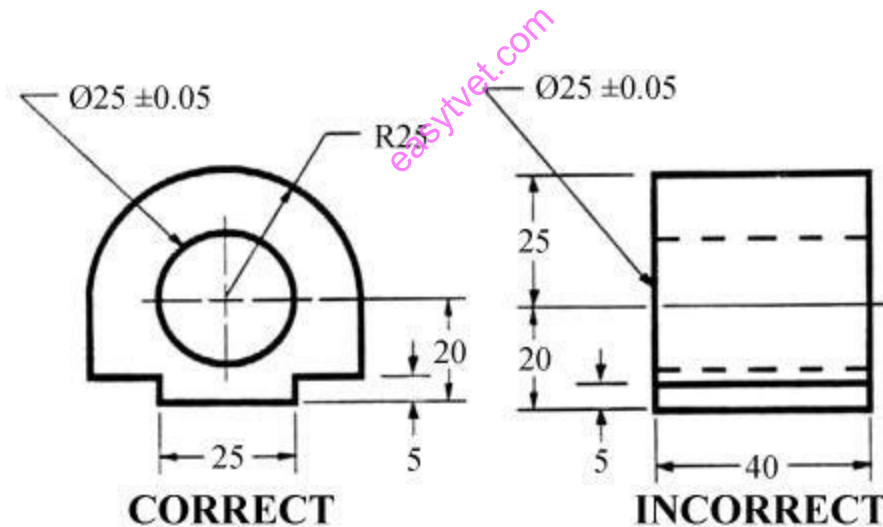

Appropriate and inappropriate dimensioning.

In order to get the feel of what dimensioning is all about, we can start with a simple rectangular block. With this simple object, only three dimensions are needed to describe it completely (figure 2.45). There is little choice on where to put its dimensions.

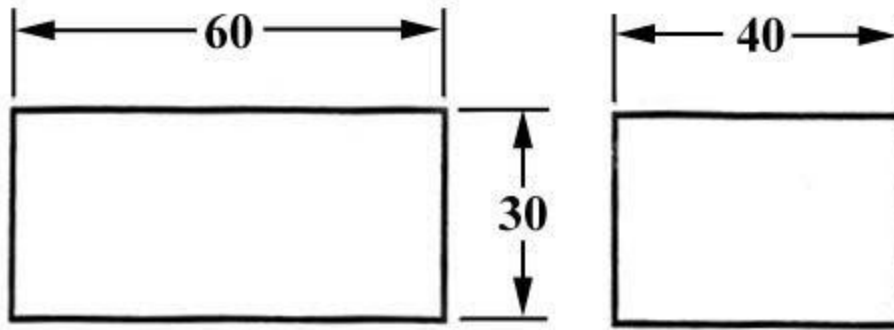

Simple Object.

We have to make some choices when we dimension a block with a notch or cutout (figure 2.46). It is usually best to dimension from a common line or surface. This can be called the datum line of surface. This eliminates the addition of measurement or machining inaccuracies that would come from "chain" or "series" dimensioning. Notice how the dimensions originate on the datum surfaces. We chose one datum surface in figure 2.46, and another in figure 2.47. As long as we are consistent, it makes no difference. (We are just showing the top view).

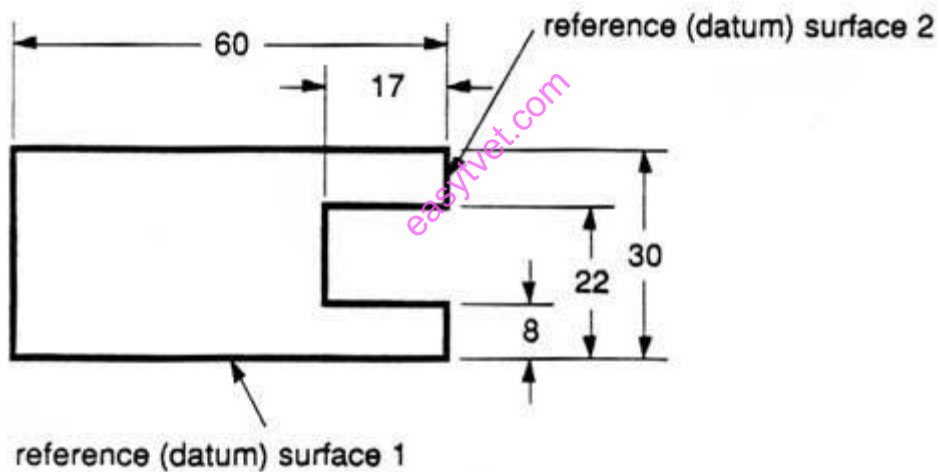

Surface datum

NEW reference (datum) surface

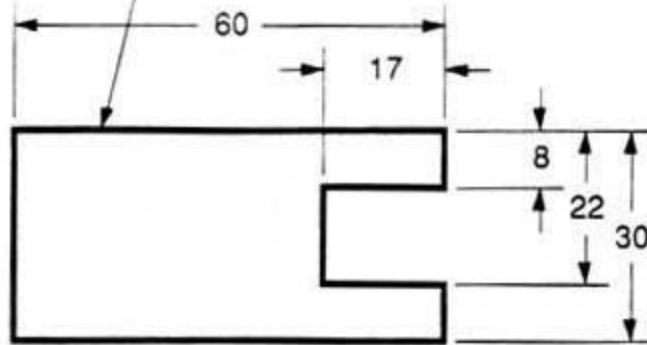

Surface datum example.

In figure 2.48 we have shown a hole that we have chosen to dimension on the left side of the object. The  $\varnothing$  stands for "diameter".

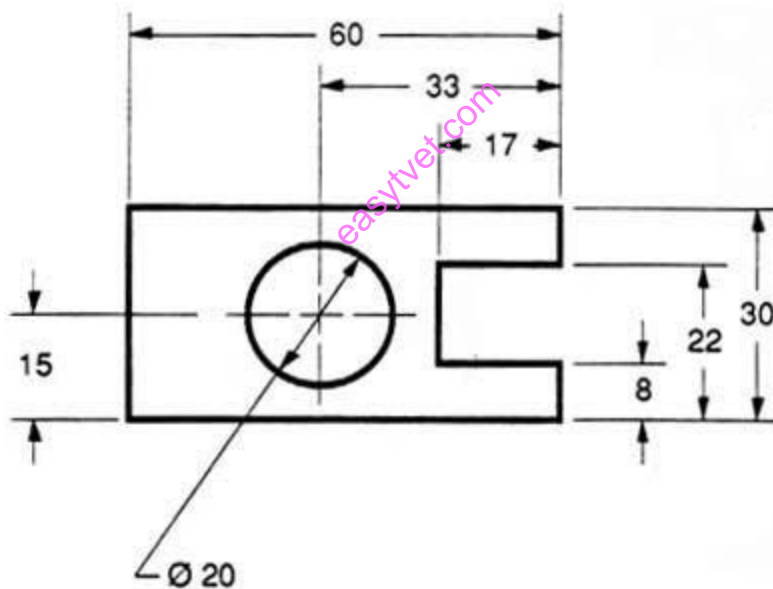

Dimensioned hole.

When the left side of the block is "radiuses" as in figure 2.49, we break our rule that we should not duplicate dimensions. The total length is known because the radius of the curve on the left side is given. Then, for clarity, we add the overall length of 60 and we note that it is a reference (REF) dimension. This means that it is not really required.

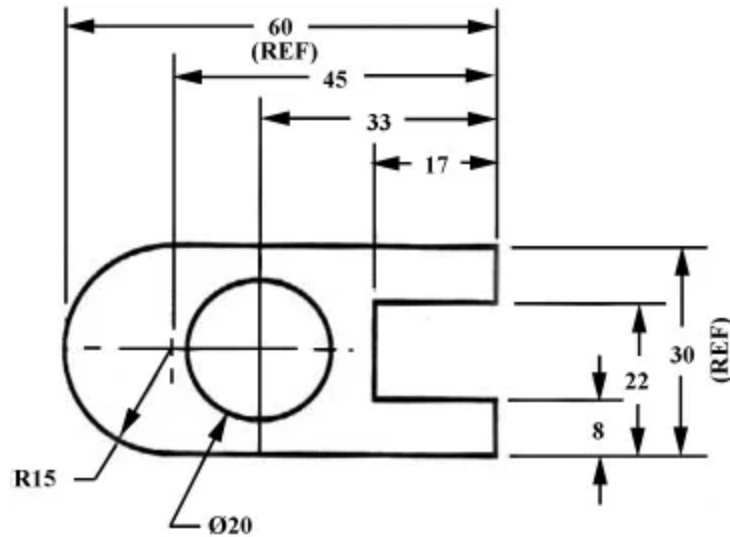

Directly dimensioned hole.

Somewhere on the paper, usually the bottom, there should be placed information on what measuring system is being used (e.g. inches and millimeters) and also the scale of the drawing.

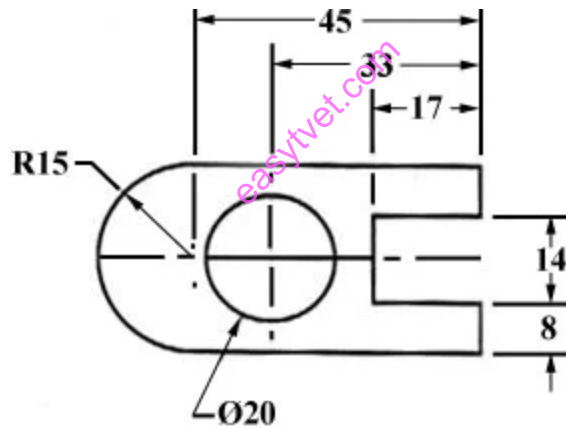

Example of a directly dimensioned hole.

This drawing is symmetric about the horizontal centreline. Centrelines (chain-dotted) are used for symmetric objects, and also for the centre of circles and holes. We can dimension directly to the centreline. In some cases this method can be clearer than just dimensioning between surfaces.

### Schematic/layout

A schematic, or schematic diagram, is a representation of the elements of a system using abstract, graphic symbols rather than realistic pictures.

### Circuit

Electric **circuit** is a path for transmitting electric current. An electric **circuit** includes a device that gives energy to the charged particles constituting the current, such as a battery or a generator; devices that use current, such as lamps, electric motors, or computers; and the connecting wires or transmission lines.

### Types of Circuits

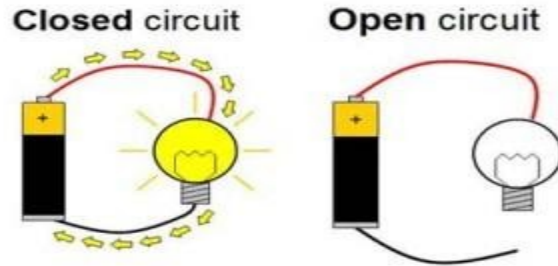

Figure 76: Closed and Open Circuit

### Closed Circuits & Open Circuits

A **closed circuit** has a complete path. An **open circuit** does not. In order for a circuit to work, it must be closed; thus, open circuits aren't functional. That may be a hard idea to grasp at first, but circuits are very different from open restaurants or open doors. When a circuit is open, the current can't flow through.

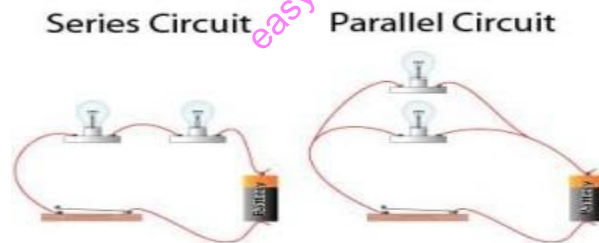

Figure 77: Series and Parallel Circuits

### Series Circuits and Parallel Circuits

A **series circuit** is a circuit in which the same current flows through all components of the circuit. The current only has one path to take. If you've ever had trouble with Christmas lights, you might know a little about series circuits. If the lights are constructed in a series circuit (as many holiday lights are), when one bulb is missing or burnt out, the current cannot flow and the lights won't turn on. Series circuits can be very frustrating because if they don't work, you have to figure out which piece is responsible for the whole.

A **parallel circuit** is a circuit in which the components are arranged so that the current must break up (with bits flowing across each parallel branch) before meeting and combining again.

Because the current divides, each component is assured a charge. And if one path breaks, the other paths will still work because they aren't reliant on each other. (So if you're looking for new Christmas lights, check that they're in a parallel circuit arrangement to avoid a lot of hassle.) Houses are always built with parallel circuits so that if one light burns out, your entire house won't lose power.

**Short circuit** is a circuit that allows the current to travel along an unintended path. In this way, it encounters little (or no) resistance. The piece of the circuit bypassed by the short circuit may cease to function and a large amount of current may begin flowing. This causes the wires to heat up and can potentially cause a fire. As we've already discussed, circuit breakers and fuse boxes are put in place to cut off circuits as a safety measure when a short circuit occurs. A short circuit is not, as some believe, just any electrical malfunction.

### Circuit diagram

A circuit diagram is a visual display of an electrical circuit using either basic images of parts or industry standard symbols. Symbol usage depends on the audience viewing the diagram. These two different types of circuit diagrams are called pictorial (using basic images) or schematic style (using industry standard symbols). A schematic style circuit diagram is used to give a visual representation of an electrical circuit to an electrician. The pictorial style circuit diagram would be used for a broader, less technical audience.

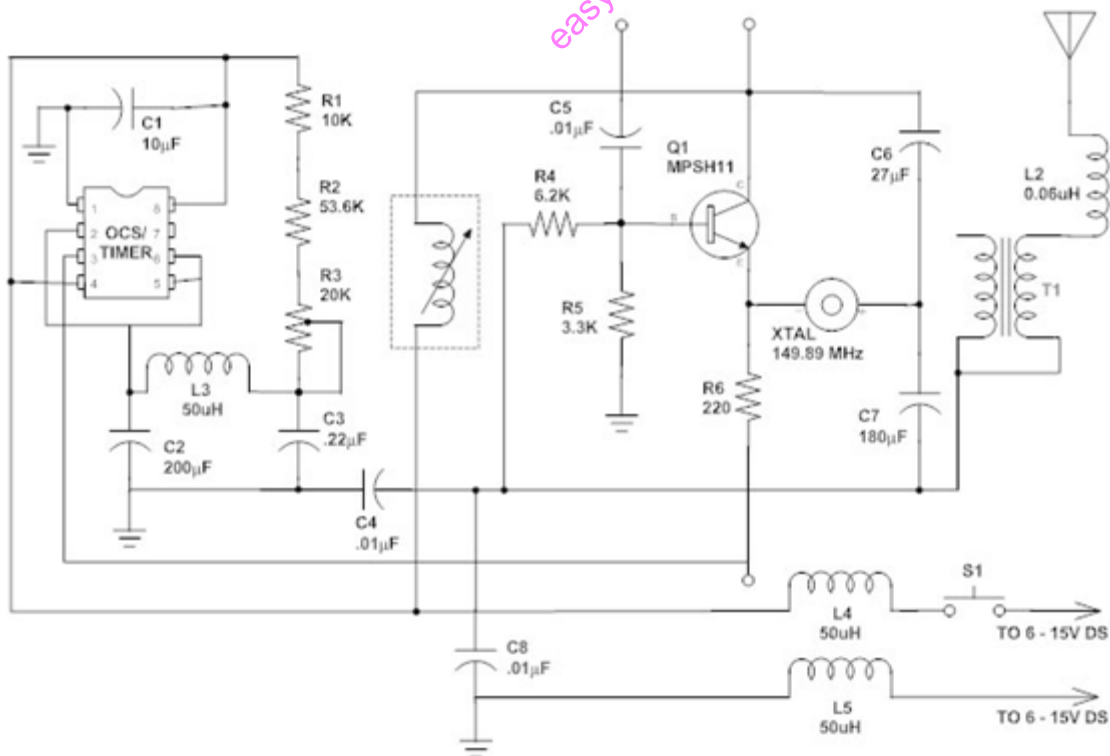



## Figure 78: Circuit Diagram

### Circuit Diagram Symbols

There are hundreds of different symbols that can be used in a circuit diagram. These include simple images of objects such as a battery or a resistor for a pictorial style circuit diagram, or industry-standard symbols for objects such as capacitors or inductors.

### How to Create a Circuit Diagram

There are many different ways to create a circuit diagram. They can be created manually, but the more efficient way is to use diagramming software such as Smart Draw, which is designed for this purpose. Diagramming software that is specifically designed for creating a circuit diagram offers several advantages.

- i. It is fast and allows for simple construction.
- ii. It provides access to thousands of symbols.
- iii. It is easy to share electronically.
- iv. It provides precise placement of objects.
- v. It is easy to edit.

Smart Draw allows you to quickly, accurately, and easily create a circuit diagram. It also allows you to create personal custom libraries of symbols you commonly use.

### Electrical Wiring

Electrical Wiring is a process of connecting cables and wires to the related devices such as fuse, switches, sockets, lights, fans etc. to the main distribution board is a specific structure to the utility pole for continues power supply.

### Wiring Diagram

A wiring diagram is a simple visual representation of the physical connections and physical layout of an electrical system or circuit. It shows how the electrical wires are interconnected and can also show where fixtures and components may be connected to the system.

### When and How to Use a Wiring Diagram

Use wiring diagrams to assist in building or manufacturing the circuit or electronic device. They are also useful for making repairs.

DIY enthusiasts use wiring diagrams but they are also common in-home building and auto repair.

For example, a home builder will want to confirm the physical location of electrical outlets and light fixtures using a wiring diagram to avoid costly mistakes and building code violations.

### **How a Wiring Diagram Different from a Schematic**

A schematic shows the plan and function for an electrical circuit, but is not concerned with the physical layout of the wires. Wiring diagrams show how the wires are connected and where they should/are located in the actual device, as well as the physical connections between all the components.

### **How a Wiring Diagram Different from a Pictorial Diagram**

Unlike a pictorial diagram, a wiring diagram uses abstract or simplified shapes and lines to show components. Pictorial diagrams are often photos with labels or highly-detailed drawings of the physical components.

### **Standard Wiring Diagram Symbols**

Most symbols used on a wiring diagram look like abstract versions of the real objects they represent. For example, a switch will be a break in the line with a line at an angle to the wire, much like a light switch you can flip on and off. A resistor will be represented with a series of squiggles symbolizing the restriction of current flow. An antenna is a straight line with three small lines branching off at its end, much like a real antenna.

easyvet.com

### **Learning Activities**

Figure below shows a part of a machine. Draw full size, in 3<sup>rd</sup> angle projection, the following views:

- i. Front elevation viewed from arrow X,
- ii. End elevation viewed from arrow Y
- iii. Plan

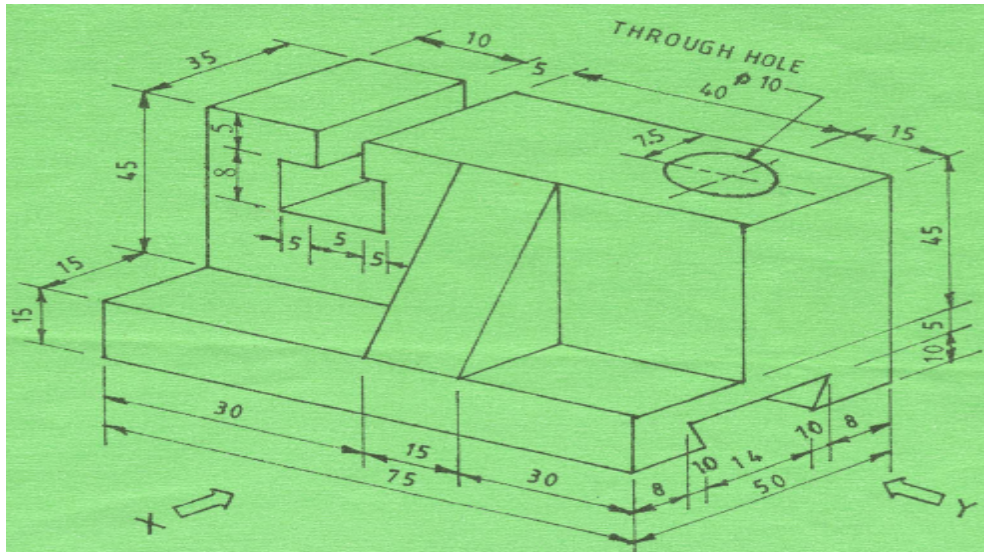

Figure 79: Parts of a Machine

### Self-Assessment

1. What is drawing in technology? (4 Marks)
2. What are the types of drawing? (5 Marks)
3. How sketching and technical drawing are related? (4 Marks)
4. What is outline in drawing? (2 Marks)
5. How can I improve my technical drawing skills? (5 Marks)

### 2.1.2.5: Tools, Equipment and Materials

- i. Mechanical pencil and clutch pencil.
- ii. Technical pens.
- iii. Rulers. .
- iv. Compass.
- v. Drawing boards.
- vi. Erasers.
- vii. Sharpeners
- viii. T-Square.
- ix. Technical Drawing Set

### References

- i. <https://professional-electrician.com/technical/identification-electrical-wiring/>
- ii. <https://girishsab.wordpress.com/identification-of-various-types-of-electrical-accessories-and-components/>

- iii. [https://ocw.mit.edu/courses/mechanical-engineering/2-007-design-and-manufacturing-i-spring-2009/related-resources/drawing\\_and\\_sketching/](https://ocw.mit.edu/courses/mechanical-engineering/2-007-design-and-manufacturing-i-spring-2009/related-resources/drawing_and_sketching/)

### Model answers to Self-assessment Questions

1. **Technical drawing, drafting or drawing** (4 Marks)

This is the act and discipline of composing drawings that visually communicate how something functions or is constructed.

2. Types of Drawing (5 Marks)

- i. Illustration Drawing.
- ii. Life Drawing.
- iii. Emotive Drawing.
- iv. Analytic Drawing.
- v. Perspective Drawing.
- vi. Diagrammatic Drawing.
- vii. Geometric Drawing.

3. **Technical sketching Visas technical drawing:** (4 Marks)

Technical sketches are made with a pencil, paper, and an idea, while technical drawing advances a sketch to follow specific technical drawing guidelines that employ the use of tools, such as isometric graph paper and the aid of a computer.

4. **Outline in drawing:** (2 Marks)

The line by which a figure or object is defined or bounded; contour.  
A drawing or sketch restricted to line without shading or modeling of form.

5. **Tips For Improving Your Drawing Skills**  
(5Marks)

- i. Go draw something. Repeat.
- ii. Look at **drawings**. Whether simple line **drawings** or meticulously detailed renderings, you can learn a lot from looking at the work of others.
- iii. Draw from **drawings**.
- iv. Draw from photographs.

- v. Draw from life.
- vi. Take a class.

## 2.1. Select Correct Types and Sizes of Cables

### Introduction

A **cable** is a thick wire, or a group of wires inside a rubber or plastic covering, which is used to carry electricity or electronic signals. **Cable** is used to refer to television systems in which the signals are sent along underground wires rather than by radio waves.

**For selection of proper cable, the following conditions should be satisfied:**

- i. **Cable** derating amp should be higher than full load current of load.
- ii. **Cable** voltage drop should be less than defined voltage drop.
- iii. **Cable** short circuit capacity should be higher than system short circuit capacity at that point.

### Performance Standard

- i. Reading and interpretation of drawings
- ii. Determination of correct type, size and quantity of cables and related consumables.
- iii. Selection of tools and equipment.
- iv. Identification and selection of correct PPE

### Information Sheet

#### Insulators, Conductors and Cables Conductors

Conductors are the materials or substances which allow electricity to flow through them. They conduct electricity because they allow electrons to flow easily inside them from atom to atom. Also, conductors allow the transmission of heat or light from one source to another.

#### Insulator

An insulator is a material which is a poor conductor of electricity or heat. Some common insulators include wood, plastic, glass, porcelain and Styrofoam; Styrofoam and plastic see wide use in household applications.

#### Cable

A cable is a thick wire, or a group of wires inside a rubber or plastic covering, which is used to carry electricity or electronic signals. ... Cable is used to refer to television systems in which the signals are sent along underground wires rather than by radio waves.

## **Types of conductors (e.g., copper, aluminium) and their applications**

Many materials are used to transmit electrical energy, but those most frequently specified for types of conductors are copper, copper-covered steel, high strength copper alloys, and aluminum.

### **Copper conductor**

**Copper** is the electrical **conductor** in many categories of electrical wiring. **Copper wire** is used in power generation, power transmission, power distribution, telecommunications, electronics circuitry, and countless types of electrical equipment. **Copper** and its alloys are also used to make electrical contacts.

### **Aluminum conductor**

Aluminium conductor steel-reinforced cable (ACSR) is a type of high-capacity, high-strength stranded conductor typically used in overhead power lines. The outer strands are high-purity aluminium, chosen for its good conductivity, low weight, low cost, resistance to corrosion and decent mechanical stress resistance.

### **Application of conductors in daily life**

- i. Mercury is used in thermometers to absorb heat
- ii. Aluminium is used for making frying pans to absorb heat quickly.
- iii. Motor vehicle engines are made of iron to conduct away heat- car radiators are made of iron to conduct away heat- refrigerators have copper pipes at the back for conducting away heat from coolant.
- iv. Wire gauze conducts heat quickly to the container placed on it for heating.
- v. The iron plate of an electric iron is made of steel to absorb heat quickly- the head of a soldering iron is made of copper to be heated quickly.

### **Properties of conductors e.g. conductivity, temperature, weight, strength**

The basic properties of conductors allow us to describe many physical phenomena. Consider the following man standing inside a thin metal wire frame.

### **Conductivity of conductors**

Conductivity is the measure of the ease at which an electric charge or heat can pass through a material. A conductor is a material which gives very little resistance to the flow of an electric current or thermal energy. ... Electrical conductivity tells us how well a material will allow electricity to travel through it.

### **Temperature effects to conductors**

The electrical conductivity of a **conductor** will decrease with an increase in **temperature!** where  $\rho_{\text{room temp}}$  is the room **temperature** resistivity and  $\alpha$  is the **temperature** coefficient of resistivity.

Consider the effect of increasing the temperature on the conductivity of conductors. Let's look at the factors that go into conductivity and consider how each of these are affected:

$$\text{Sigma } (\Sigma) = n q m$$

- i. First consider what will happen to  $n$  as temperature increases. The electrons that are
- ii. Charge carriers in a conductor will gain energy and go into higher energy levels. However, these energy levels are all still in the valance band. So, the number of charge carriers will not change for a conductor with an increase in temperature.
- iii. Now consider  $q$ . As temperature increases, the charge on each carrier will not change.
- iv. Finally, what happens to the mobility? Recall that mobility is the drift velocity divided by the electric field strength. Temperature won't affect the electric field strength. But it will decrease the drift velocity because as the temperature increases, the atomic vibrations will increase, which will cause more collisions of the electrons with the crystal lattice. Hence the drift velocity will decrease.

**Conclusion:**

The electrical conductivity of a conductor will decrease with an increase in temperature! The relationship is not linear; however, if we consider the resistivity, which is the reciprocal of conductivity, we do get a linear relationship:

$$\rho(T) = \rho_{\text{roomTemp}} [1 + \alpha (T - T_{\text{room}})]$$

where  $\rho_{\text{roomTemp}}$  is the room temperature resistivity and  $\alpha$  is the temperature coefficient of resistivity.

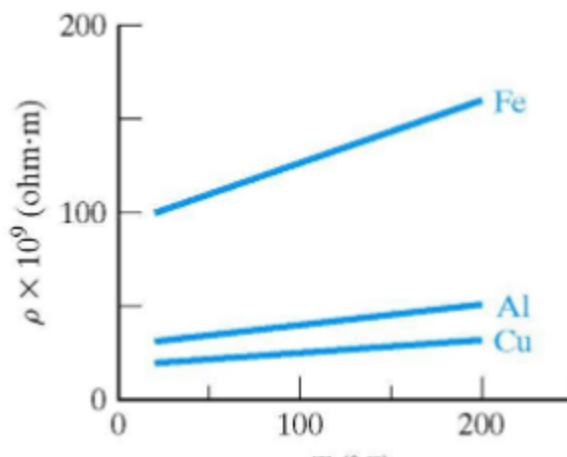

Figure 80: Effects of Temperature to Conductors

### **Weight of Conductors**

#### **To determine the weight of a conductor,**

Multiply the mass per centimeter value from Step 13 by the planned length of the wire (in centimeters). This will give you the total mass of the wire, expressed in grams. Multiply the wire's total mass by 0.0022 to convert it to pounds.

### **Strength of Conductor**

**Copper:** Copper has a high conductivity and greater tensile strength.

**Aluminium:** Aluminium has about 60% of the conductivity of copper; that means, for the same resistance, the diameter of an aluminium conductor is about 1.26 times than that of a copper conductor.

### **Types of insulators (e.g. PVC, rubber, porcelain, fibre)**

#### **PVC insulators**

PVC is a polymer with good insulation properties, but because of its higher polar nature the electrical insulating property is inferior to non-polar polymers such as polyethylene and polypropylene.

#### **Rubber insulator**

In either its natural or synthetic form, rubber has been used as an insulator since 1870. The tightly bound electrons are not free to be shared by neighbouring atoms. The properties of rubber also cause the electrons to slow down and eventually prevent them from moving at all. Electrical cords are a good example of rubber being used as an insulator. If a cord is frayed and has damaged the outer rubber lining, the rubber will not be an effective insulator. If the conductors (wires) are exposed, it is necessary to replace the cord.

#### **Porcelain insulators**

Porcelain is made from a refined, white clay called kaolin and is fired at temperatures as high as 2,600° Fahrenheit. It is sometimes referred to as “China,” because the manufacturing process was developed centuries ago in that country.

Porcelain also has a solid color throughout, usually white. Porcelain is denser and less absorbent than ceramic, so it can easily withstand moisture and harsher weather conditions. Because of the cost of materials and an intensive manufacturing process, porcelain is more expensive to produce.



## **Fibre insulator**

Natural **Fiber**: Some natural **fibers** including cotton, wool, straw, and hemp are used as **insulation** materials. ... Wool has a similar R-value as other more common types of **insulation**. Hemp **insulation** is relatively unknown and not used widely, but has a similar R-value to other types of fibrous **insulation**.

## **Properties of insulators e.g. resistivity**

**Property 1:** In an insulator, the valence electrons are tightly held together. They do not have free electrons to conduct electricity.

**Property 2:** The ability of the material to not allow the electric current to pass through it is called electrical resistance. The resistance of an insulator per unit cross-sectional area per unit length is called resistivity. Insulators have very high resistivity. For example, insulators like glass have a resistivity value as high as  $10^{12} \Omega\text{m}$ . The resistance of the insulator is considerably reduced in the presence of moisture and when there is an increase in temperature.

**Property 3:** Insulators have large dielectric strength. The dielectric strength is the maximum electric field that the insulator can withstand without undergoing electrical breakdown and becoming electrically conductive.

**Property 4:** Good insulators have a high air permeability (the ability of the material to allow air to flow through its pores) since air itself is an insulator.

## **Factors to consider when selecting cables e.g. load, length**

The key to the successful operation of a cable system is to select the most suitable cable for the application, make a correct installation, and perform the required maintenance. In this technical article, discussion is based on the correct cable selection and application for power distribution and utilization.

## **Cable selection can be based upon the following five key factors:**

The key to the successful operation of a cable system is to select the most suitable cable for the application, make a correct installation, and perform the required maintenance.

In this technical article, discussion is based on the correct cable selection and application for power distribution and utilization.

- i. Cable installation
- ii. Cable construction
- iii. Cable operation (voltage and current)
- iv. Cable size

## v. Shielding requirements

### **Cable installation**

Cables can be used for outdoor or indoor installations depending upon the distribution system and the load served.

A good understanding of local conditions, installation crews, and maintenance personnel is essential to assure that the selected cable system will operate satisfactorily! Many times cable insulation is damaged or weakened during installation by applying the incorrect pulling tensions.

Designs of conduit systems not only should minimize the number of conduit bends and distances between manholes but also should specify the pulling tensions.

### **Cable construction**

Selection and application of cable involves the type of cable construction needed for a particular installation. Cable construction involves conductors, cable arrangement, and insulation and finish covering.

### **Conductors**

Conductor materials such as copper and aluminum should be given consideration with regard to workmanship, environmental conditions, and maintenance. The requirements for aluminum conductors with regard to these factors are more critical than for copper conductors.

### **Cable arrangement**

Conductors can be arranged to form single-conductor or three-conductor cable. There are certain advantages and disadvantages to both types of arrangements. Single conductors are easier to install, easier to splice, and allow the formation of multiple-cable circuits.

On the other hand, they have higher reactance than three-conductor cable. Shielded single conductors carry high shield currents, and consideration must be given to preventing overheating of the cable.

Single-conductor cables are subject to considerable movement owing to the mechanical stresses produced by the short circuit currents or high inrush currents. Three-conductor cable with an overall jacket has the lowest reactance, and voltage stress distribution is balanced owing to equivalent spacing between conductors.

The availability of ground wire in three-conductor cable or a separate ground wire with single-conductor cable is an important consideration. Since the ground conductor in three-conductor cable construction provides the lowest impedance path, it offers a good system ground.

Similarly, a separate ground in the same conduit as the power conductors provides a better ground return path than a ground path via the equipment or building steel.

The selection and application of a cable system should be based on correct selection of the type of cable arrangement required for the purpose.

### **Insulation and finish covering**

The selection of cable insulation and finish covering is normally based on the type of installation, ambient operating temperature, service conditions, type of load served, and other criteria as applicable. In many installations unusual conditions may be prevalent, such as corrosive atmosphere, high ambient temperature, insect and rodent hazard, presence of oil and solvents, presence of ozone, and extreme cold.

In certain applications, two or more of these unusual conditions may be present, in which case the selection of suitable cables becomes much more difficult.

### **Cable operation**

The insulation of the cable must be able to withstand the voltage stresses experienced during normal and abnormal operating conditions. Therefore, the selection of the cable insulation should be made on the basis of the applicable phase-to-phase voltage and the general system category which are classified as either 100%, 133%, or 173% insulation levels.

These insulation levels are discussed as follows:

#### **100% level:**

Cables in this category may be applied where the system is provided with relay protection which normally clears ground faults within 1 minute. This category is usually referred to as the grounded systems.

#### **133% level:**

Cables in this category may be applied where the system is provided with relay protection which normally clears ground faults within 1 hour. This category is usually referred to as the low resistance grounded, or ungrounded systems.

#### **173% level:**

Cables in this category may be applied where the time needed to de-energize the ground fault is indefinite. This level is recommended for ungrounded and for resonant grounded systems.

The current capacity that the cable needs to carry is determined by the load it serves.

In cases where cables may be load cycled, the current carrying capacity may be calculated by the following formula:

$$I_{eq} I_{eq} = = \frac{EI^2 t}{T} \frac{EI^2 t}{T}$$

Where:

$I_{eq} I_{eq}$  is the equivalent current carrying capacity

***I I*** is the constant current for a particular time period

***t t*** is the time period of constant current

***T T*** is the total time of duty cycle

***E E*** is the voltage of the cable

The equivalent current carrying capacity should be used for selecting the conductor sizes for thermal withstand.

### **Cable size**

The selection of cable size is based upon the following factors:

- i.** Current carrying capacity
- ii.** Voltage regulation
- iii.** Short circuit rating

These factors should be evaluated before selecting a cable size! In many instances voltage regulation and short circuit rating factors are overlooked. This oversight can result in danger to property and personnel, as well as destruction of the cable itself.

### **Current carrying capacity**

The current carrying capacity of a cable is based upon its thermal heating. The NEC publishes tables listing the current capacity for various-sized cables. The ICEA publishes current ratings for various types of insulation and installation conditions.

The current rating of cable is based upon certain spacing to permit thermal dissipation. If this spacing is smaller where the cable is to be installed, then derating of cable is required.

Home / Technical Articles / Five key factors to the correct cable selection and application

### **Voltage regulation**

In correctly designed electrical power systems, voltage regulation is usually not a problem.

Voltage drops for excessively long runs at low voltage should be checked to ensure correct load voltage. In rotating loads, checks should be made both on steady-state voltage regulation and during starting.

### **Short circuit rating**

The cable size selected should be checked for short circuit withstand capability, which should be based upon the circuit opening time for short circuit condition. In other words, the cable should hold without any thermal damage to it until such time as the fault can be removed by the switching device, such as a circuit breaker or fuse.

## Shielding

In selecting and applying cables at medium voltage, a major consideration involves whether the cable should be shielded or non-shielded. The condition under which shielded cable is to be selected and applied is explained in the following discussion.

The application of shielded cable involves the following considerations:

- i. Type of insulation system
- ii. Whether the system neutral is grounded or ungrounded
- iii. Safety and reliability requirements of the system

In power systems where there is no shield or metallic covering, the electric field is partly in the air and partly in the insulation system! If the electric field is intense, such as in the case of high and medium voltage, surface discharges will take place and cause ionization of the air particles. The ionization of air causes ozone generation, which can deteriorate certain insulations and finish coverings.

Shielding should be considered for nonmetallic cable operating in excess of 2kV where any of the following conditions exist:

### Damp conduits

- i. Connection to aerial wires
- ii. Transition from a conducting to a nonconducting environment (such as from moist to dry earth)
- iii. Dry soil
- iv. Dirty environment containing soot, salt, and other contaminants
- v. Where safety to personnel is required
- vi. Where radio interference is expected

### Identification of sub- circuits

Sub-circuits are self-contained circuits that appear as "black boxes" in other circuits. A given sub-circuit may be used any number of times at multiple levels just as long as it does not become a sub-circuit of itself. Cards and chips both begin as circuits designed on the circuit board.

Sub-circuits are self-contained circuits that appear as "black boxes" in other circuits. A given sub-circuit may be used any number of times at multiple levels just as long as it does not become a sub-circuit of itself.

There are three types of sub-circuits: cards, chips and plug-ins. Plug-ins will be discussed in a separate section.

Cards and chips both begin as circuits designed on the circuit board. The difference between a card and a chip is that the internal structure of a card remains visible and editable while a chip is closed and opaque.

### **Types and sizes of cables**

Cables may be classified into the following types depending upon their purpose:

#### **Ribbon Electric Cables**

It consists of multiple insulated wires running parallel with one another and is used for transmission of multiple data simultaneously. For example, this is used to connect the CPU with the motherboard and is generally used for interconnection of networking devices.

#### **Shielded Cables**

It consists of 1 or 2 insulated wires which are covered by a woven braided shield or aluminium Mylar foil for better signal transmission and removing irregularities in the frequency of power and external interference in radio. These cables transmit high voltage electric current and are protected by a shield.

#### **Twisted Pair Cables**

It has two or more insulated copper wires which are twisted with each other and are colour-coded. These types of wires are usually used in telephone cables and the resistance to external interference can be measured by the number of wires.

#### **Coaxial Cables**

This consists of solid copper or steel conductor plated with copper which is enclosed in the metallic braid and metallic tape. This is entirely covered with an insulated protective outer jacket. These types of cables are used for computer networking and audio-video networking.

#### **Fibre Optics Cable**

There are these types of cables which transport optical data signals from an attached light source to the receiving device. We are pretty much aware of what is an optical fibre and its uses in a wide variety of applications.

#### **Measurements and estimations of cable lengths and sizes**

Thicker cables offer less resistance to electric flow. They offer more electrons to carry a charge and a greater number of paths through which the electrons can travel. As a result, given the same voltage, a thicker cable carries more current. Choose a cable's exact thickness to meet a

target level of resistance. The other relevant factors are the length of the cable, which external needs usually dictate and the resistivity of the cable's material.

Divide the voltage running through the cable by your target current. If, for instance, 120 volts will act on the cable, and you want 30 amps to run through it:  $120 / 30 = 4$ . This is your target resistance, measured in ohms.

Multiply the cable's length by its material's resistivity. Copper, for instance, has a resistivity of  $1.724 \times 10^{-8}$  ohm meters at room temperature. If your cable must measure 30,000 meters in length:

$$30,000 \times 1.724 \times 10^{-8} = 0.0005172\text{-ohm sq. m.}$$

Divide the answer by your target resistance:

$$0.0005172 / 4 = 0.0001293.$$

This is the cable's necessary cross-sectional area.

Divide the cable's area by pi:  $(0.0001293) / 3.142 = 4.1152 \times 10^{-5}$ .

Find the square root of this answer:  $(4.1152 \times 10^{-5})^{0.5} = 0.006415$ . This is the cable's radius, measured in meters.

Multiply your answer by 39.37 to convert it to inches:  $0.006415 \times 39.37 = 0.2526$ .

Multiply the answer by 2:  $0.2526 \times 2 = 0.5052$  inches. This is the cable's necessary thickness. It approximately corresponds with the standard 16-gauge cable.

### Relevant IEE regulations

- i. The cable must be of complete chemical and physical stability.
- ii. The cable must be provided with suitable mechanical protection.
- iii. The cable must have a proper thickness of insulation.
- iv. The conductors used in cables must be tinned and stranded copper or aluminum of high conductivity.

### Learning Activities

Three most commonly used cable sizes of 1, 1.5 and 2.5mm twin and earth there are in fact several other larger sizes of cable that include 4mm, 6mm, 10mm and 16mm. Identify these cables according to their size and state where they are used.

### Self-Assessment

1. What is the meaning of IEE in electrical? (2 Marks)
2. What are the factors to be considered when selecting cable size? (2 Marks)  
What are the factors on which the insulation layer thickness of the conductor is decided in the cables? (1Mark)

3. How do you protect a cable from mechanical injury? (3 Marks)  
What is a cable? (2 Marks)

### Tools, Equipment and Materials

- i. Tape Measure.
- ii. Hammer.
- iii. Spirit Level.
- iv. Flashlight.
- v. Utility Knife.
- vi. Screwdrivers.
- vii. Straight-Blade Screwdrivers

### References

- i. <https://sciencing.com/how-8093550-calculate-size-cable.html>
- ii. <https://www.zarebasystems.com/articles/ceramic-vs-porcelain-insulators>
- iii. <https://electrical-engineering-portal.com/cable-selection-application>
- iv. <https://byjus.com/physics/types-of-cables/>

### Model Answers to the self-assessment

1. IEE (Institution of Electrical Engineers) (2 Marks)

The Institution of Electrical Engineers (IEE) was a British professional organization of electronics, electrical, manufacturing, and Information Technology professionals, especially electrical engineers. It began in 1871 as the Society of Telegraph Engineers.

2. **Factor to consider when selecting size of a Cable** (4 Marks)

- i. Current carrying capacity
- ii. Voltage regulation
- iii. Short circuit rating
- iv. Length of the cable run.

3. **The factors on which the insulation layer thickness of the conductor is decided in the cables**

It depends on the voltage. (1 Mark)

4. **Cable Protection from mechanical injury** (3 Marks)

By using the process of armoring, the cable can be protected from mechanical injury.

5. **Cable** (2 Marks)



A cable is a thick wire, or a group of wires inside a rubber or plastic covering, which is used to carry electricity or electronic signals. Cable is used to refer to television systems in which the signals are sent along underground wires rather than by radio waves.

[easytvvet.com](http://easytvvet.com)

## 2.2. Install Cables for Lighting and Power Points

### Introduction

Homes typically have several kinds of home **wiring**, including electrical **wiring for lighting and power** distribution, permanently **installed** and **Power points** (wall outlets); **Light** fixtures and switches; Telephone; Internet; Television, *etc etc* .

### Performance Standard

1. Safety procedures and regulations installation of lighting and power points
2. Wiring of lighting and power points
3. Grounding of Lighting and power points
4. Installation quality checking

### Information Sheet

#### Cable joint and termination

The cable joints and terminations provide a means of making reliable electrical connections between different cables or between the electrical cable and the terminals of equipment.

#### Types of cable joints and termination

##### Cable joints

A joint is a connection of two lengths of conductors by a method which ensures a continuous path for the unimpeded flow of an electrical current. This connection is applied to the end of a conductor prepared in such a way that it is suitable for connection to the terminal to which it is to be connected by mechanical means.

In making a joint, care must be taken to ensure that there must be sufficient contact area between the two current carrying surfaces. This is to ensure that heat is not generated on such surfaces on account of increased resistance. They are used to join cables in order to complete the circuit.

There are three main types of electrical joints, also known as splices: The Western Union splice, the tap splice and the fixture splice.

- i. Bell hangers joint/ The Western Union splice/ Married joint
- ii. Telegraph joint
- iii. A tap splice (Tee Joint)
- iv. A fixture splice

#### Bell hangers joint

This joint at times is also called straight twist joint it is not a strong type and so it is used where more tensile stress is placed on the conductors which are usually solid core and insulated.



Figure 81: Bell hangers joint

### The Western Union splices

Connects two conductors together and is particularly useful in repairing a broken wire. The two wires are trimmed of insulation, and then each is wrapped around the other around six times.

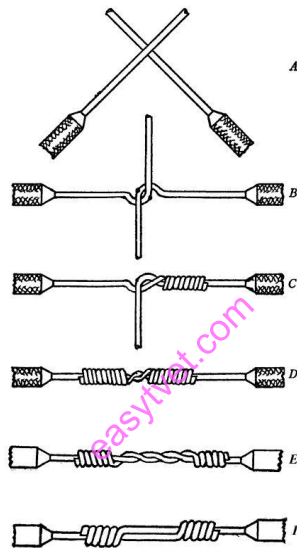
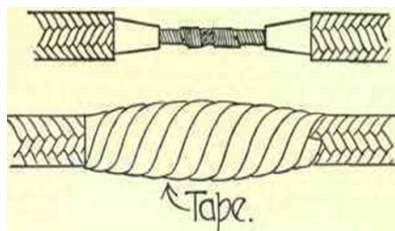

Figure 82: Western Union Splice cable joint

### Married joint

When made correctly it forms a very strong and satisfactory joint



### Tap splice (Tee Joint)

This connects a loose wire to the conductor at an angle, typically resembling a "T" shape. They are named tap splices because the loose wire can then "tap" the flow of the conductor. The wires of the loose wire are wrapped around the conductor, first with one-on-one side and then with five or more on the other.

It is a branch or TEE joint made with single core conductors

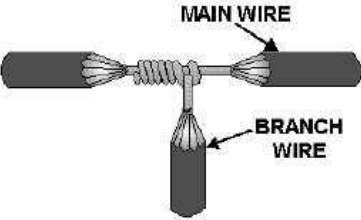

Tap splice cable joint

A **fixture splice** connects two different conductors and can be called a rat tail splice. The two exposed wires must be twisted together with a plier, then bent into place.

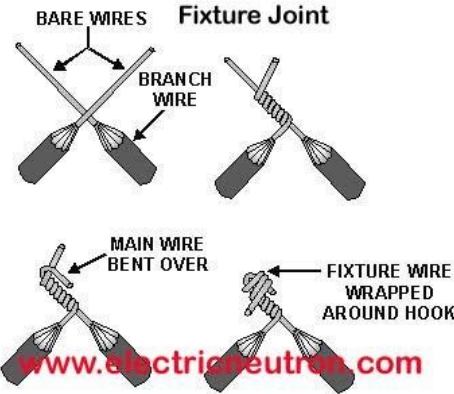

Fixture splice cable joint

**Purpose and application of cable joints and termination**

The cable joints and terminations provide a means of making reliable electrical connections between different cables or between the electrical cable and the terminals of equipment.

**Relevant IEE regulations**

The normal installation has many joints, and it follows that these must all remain safe and effective throughout the life of the system. With this in mind, regulations on joints include the following:

- i. All joints must be durable, adequate for their purpose, and mechanically strong.
- ii. They must be constructed to take account of the conductor material and insulation, as well as temperature: e.g., a soldered joint must not be used where the temperature may cause the solder to melt or to weaken. Very large expansion forces are not uncommon in terminal boxes situated at the end of straight runs of large cables when subjected to overload or to fault currents.
- iii. All joints and connections must be made in an enclosure complying with the appropriate British Standard.
- iv. Where sheathed cables are used, the sheath must be continuous into the joint enclosure.
- v. All joints must be accessible for inspection and testing unless they are buried in compound or encapsulated, are between the cold tail and element of a heater such as a pipe tracer or underfloor heating system, or are made by soldering, welding, brazing or compression.

### **Cable terminations**

The electrical cable termination is the physical and electrical connection of a cable end that connects to another cable, or to the terminal of the equipment. The cable terminations are often designed to enable the physical and electrical interconnecting of two cable ends, or a cable end and a terminal on the equipment. Remember the cable connection is not complete until all terminations are properly identified and labelled.

The methods used to terminate the cables vary according to the type of cable, type of connectors and application. The common types of terminations are crimp connection, soldered connection, compression termination and wire-wrapping connection, direct connection, loops or eye connection.

Some of the factors that determine the type are:

- i. Outdoor or indoor use
- ii. Voltage
- iii. Current
- iv. Overhead or underground
- v. Type of connector on the equipment where the cable will be connected

### **Learning Activities**

Figure below shows a 12 V solar home system layout.

- i. Draw a wiring diagram of the layout
- ii. Carry out the wiring of the control gear of the solar unit in correct sequence

- iii. Using PVC mini trunking system, install the circuits such that:
- iv. The lamps are controlled from two positions
- v. Socket outlets are wired in ring.

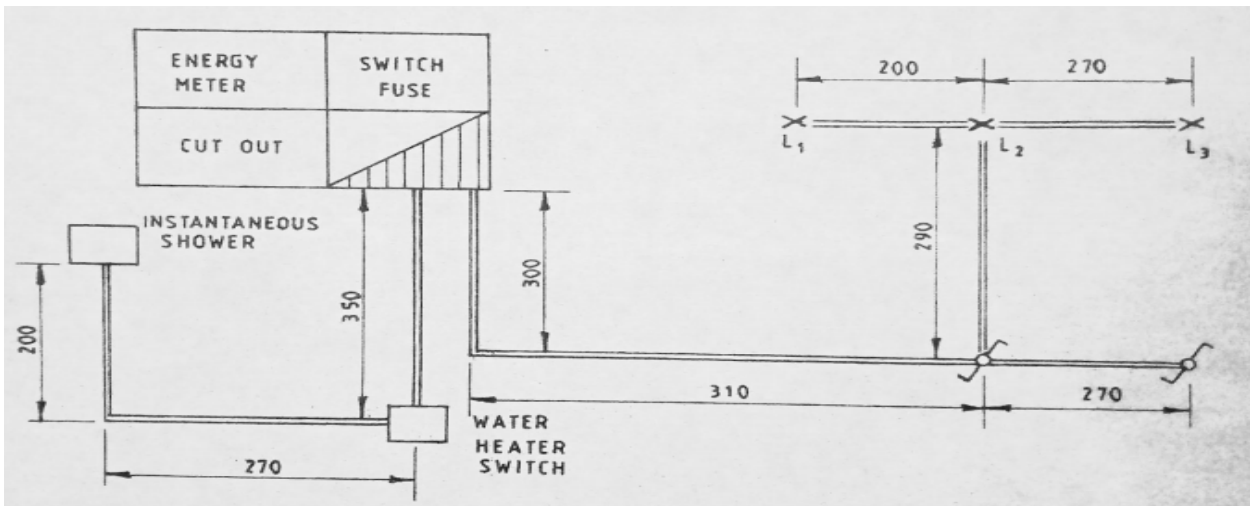

Figure 83: Solar home system layout

### Self-Assessment

1. Why are cable termination kits used? (2 Marks)
2. What are the types of cable joints? (2 Marks)
3. What are the main types of electrical terminations? (2 Marks)
4. How do you terminate electrical cables? (2 Marks)
5. Can you leave unused wire in wall? (2 Marks)

### Tools, Equipment, Supplies and Materials

- i. Needle nose crimping pliers.
- ii. Connector crimper.
- iii. Wire stripper hole for 22- to 24-gauge wire.
- iv. Built-in side cutter.
- v. Rubber coated handles for non-slip grip.
- vi. Pliers
- vii. Screw drivers
- viii. Tester
- ix. Hammer
- x. Draw wire

### References

- i. <https://kvcable.com/cable-accessories/cable-termination/>
- ii. <https://www.tlc-direct.co.uk/Book/4.4.3.htm>

### **Model Answers to the self-assessment Questions**

**1. Reason for using cable termination kits**

**(2 Marks)**

For connection of Cable to Switchgear Terminal, Transformer Terminal, Poles etc. termination kits are required. It can also be single core or 3 core / 3.5 core based on cable configuration. Termination can be for XLPE & strong PILC Cable and can be used in extreme hazardous atmosphere conditions.

**2. Types Of Cable Joints**

**(2 Marks)**

- i. The Western Union splice, The Western Union splice connects two conductors together and is particularly useful in repairing a broken wire.
- ii. The tap splice and the
- iii. Fixture splice.

**3. Types of electrical terminations:**

**(2 Marks)**

Chip, coaxial, SCSI, and waveguide. Chip terminations have a form factor of an integrated circuit (IC) chip. They are manufactured using thin-film technology. Coaxial terminations terminate coaxial ports.

4. Electrical tape is the simplest method of making electric wires safe. You also use tape on capped live electric wires as an extra precaution. Tapes can be used on loose live wires that do not fit the cap. You can simply use tape over the live wire to fit into the cap.
5. It's acceptable to leave wire in the walls. The only thing you need to do is leave the ends exposed in boxes and wire nut and tape the two legs together. That will indicate to an electrician what's going on, and if someone does try to tie into them in the future it will just pop the breaker.

**(2 Marks)**

## Install Power Intake Point

### Introduction

The main control or intake point.

main equipment at power intake for domestic consumer. main equipment at the power intake points of domestic consumers. mains electricity intake point.

### Performance Standard

1. Safety procedures and regulations
2. Selection of, tools, equipment and materials
3. Identification and selection of correct PPE
4. Meter box and components wiring
5. Installation of lead-in pipe
6. Installation of consumer main earthing terminal bonding

### Information Sheet

#### Identification of tools and equipment

Tools and equipment mean all hand tools, implements, camp equipment, drawing office and survey instruments, medical and surgical instruments and all articles of similar nature, whether or not they are of an expendable nature, which are not normally issued to officers personally for use in carrying out their official.

Basic electrical tools, equipment, and their uses include:

#### Pliers

Pliers are available in different types, shape, and sizes. They are also available in both insulated and uninsulated handles. An insulated handle should be used when working on or near hot wires. It is also used for cutting big and small wires.



Figure 84: Pliers

#### Screw Drivers:



A screwdriver comes in various sizes and with several tip shapes. Screwdrivers used by electricians should have insulated handles. Using a screwdriver for a particular job, the width of the screwdriver tip should match the width of the screw slot.



screw drivers

**Drilling Equipment**

Drilling equipment is needed to make holes in building structure passages of conduits and wires.



Driller

**Sawing and Cutting**

Saws commonly used by electricians include the crosscut, keyhole, and hacksaw.



Hark saw

## Soldering Equipment

In doing electric wiring splices and taps (connections made to wire) should be soldered, unless you use solderless connectors. Typical equipment available for soldering are shown below.



Soldering equipment

## Hammers

Hammers are used with chisels and for nailing and fitting. Below are examples of carpenter's claw hammer, lineman's hammer, and machinist's ball-peen hammer



Hammers

## Measuring Tools

To measure wire length and other items, the electrician finds considerable use for measuring tools such as the extension or zigzag rule, push-pull rule and a steel tape as shown below.



Measuring tools

## Assembling of Working Tools and Equipment

The identified tools are assembled accordingly.

## **Preparation of cables**

### **Cable stripping**

You have to be careful when removing the insulation from a cable with a cable knife. If strands are cut off, this can lead to contact resistances or even to a cable fire. On top of that, there's the very real risk of injury with fixed-blade cable knives. A safe alternative would be a cable stripper or cable knife with adjusting screws.

**A cable stripper is great for hard-to-reach places when circular cutting.** The stripper is easy to close and maneuver and allows material to be removed cleanly. We recommend using a cable stripper for longer sections like the distributor. The adjusting screw helps to set the correct blade depth.

**Stripping pliers make stripping wires and strands even easier.** Universal pliers with an integrated knife are brilliant for round or flat cables because you can adjust the cutting length and depth.

### **Cable pairing**

Twisted pair cabling is a type of wiring in which two conductors of a single circuit are twisted together for the purposes of improving electromagnetic compatibility. Compared to a single conductor or an untwisted balanced pair, a twisted pair reduces electromagnetic radiation from the pair and crosstalk between neighboring pairs and improves rejection of external electromagnetic interference.

## **Drawing in of cables**

### **Pulling NM Cable Through Conduit**

Most wire that is installed in conduit is insulated wire (usually THHN or THWN) rather than sheathed cable, such as non-metallic (NM), or Romex, cable. Running NM cable inside conduit is not a standard practice and may not be allowed in all jurisdictions.

The National Electrical Code (NEC) does not prohibit running NM cable inside conduit, but this installation is subject to conduit fill limits, just like insulated wire in conduit. Because NM cable takes up more space than individual wires, it's easier to exceed the fill limit with cable. Also, cable is difficult to pull through conduit, due to the cable's size and the sheathing, so running cable in conduit typically is limited to very short runs that do not require standard wire pulling techniques.

### **Pulling Wire with a Mouse**

A conduit mouse, also called a conduit piston, is a small cylinder of foam that is slightly smaller than the interior diameter of the conduit. You use it with a shop vacuum.

### **Tie Pull String to Wire**

Tie a strong string, called a pull string, to the loop on the wire running through the mouse.

### **Insert Mouse into Conduit**

Insert the mouse into the conduit on the end that is opposite to the end you will pull from. The mouse goes in first, followed by the string.

### **Fit Shop <sup>V<sub>ac</sub></sup> <sup>V<sub>ac</sub></sup> Hose Over Conduit**

Fit the hose of a shop vac over the other end of the conduit, and turn on the vacuum until the mouse is sucked all the way to that end, then turn off the vacuum.

### **Pull Mouse Out of Conduit**

Pull the mouse out of the conduit and untie the string from the wire loop.

### **Secure String**

Secure the string to the wires, and lubricate the wires, as needed.

### **Feed Wires into Conduit**

Feed the wires into the conduit while your partner pulls them from the other end, using the string.

### **Pulling Wire with a Fish Tape**

The most commonly used tool for pulling wire through conduit is fish tape, an electrician's tool with a long, flat metal wire wound inside a wheel-shaped spool. Fish tapes are widely available in a range of lengths starting at 25 feet. There are also nylon tapes that don't include a spool; these may be the most economical option for when you need a fish tape only for small jobs.

### **Feed End of Tape into Conduit**

Feed the end of the tape, which has a hook on it, into the same end of the conduit that you will pull from.

### **Push Tape Through Conduit**

Push the tape through the conduit, unwinding from the spool as you go. Stop feeding when the hook end emerges from the opposite end of the conduit.

### **Strip Insulation**

Strip insulation from the end of each wire, using wire strippers. Strip each wire a different amount. For example, if there are three wires, strip one about six inches, one about four inches, and one about two inches.

### **Hold Wires Together**

Hold the three wires together so their insulation is aligned. Grab all three with linesman's pliers and twist their bare ends together.

### **Bend Wire and Loop Through Fish Tape**

Bend the longest wire into a hook and loop it through the hook of the fish tape, then wrap the loop closed.

### **Wrap Fish Tape Hook**

Wrap the fish tape hook and the bare wire ends with electrical tape.

### **Apply Lubricant**

Apply lubricant to the tape, if desired. Feed the wires into the conduit while your partner pulls them through from the other end by pulling on the fish tape.

### **Cable joints**

The **cable joints** are used to connect low, medium or high voltage **cables**. The type of **cable joint** sizes, shapes and configurations vary according to the voltage, structure, insulation and the number of cores of the **cable** to be jointed.

### **Labeling of circuits**

#### **The Basic Procedure for Circuit Labeling**

**Step 1** – Number Every **Circuit**. Assign a number to each **circuit** breaker inside the breaker panel.

**Step 2** – Locate all the Devices on the **Circuit**.

**Step 3** – List down the Results.

**Step 4** – Test all the Appliance **Circuits**.

## **Step 5 – Make an Index.**

### **Conducting final checks for workmanship, conformity with instructions and job requirements**

Inspection and testing are investigative process that verifies the essential safety of electrical installations. In Great Britain, this is normally achieved by ensuring the installation complies with a British Standard known as BS7671, otherwise known as “The Wiring Regulations” or “the regs” as it is often referred to within the electrical industry.

#### **Why should it be considered?**

Generally, the older electrical installation’s get and the more they are used, the more likely they will become defective due to neglect, wear and tear or poorly executed additions and alterations.

#### **Who is responsible for instigating electrical testing?**

Duty holders (landlords, premises managers and company directors etc.) have the legal responsibility for the safety of their electrical installations. They should ensure suitable proactive action is completed as a matter of course rather than by intervention. Unfortunately, all too often electrical inspections are instigated by Local Authorities, Insurance Companies and the HSE, whereby duty holders have some demanding time frames placed on them to complete an inspection, only to find that defects are then identified which require immediate rectification, often at significant inconvenience and cost within short time frames.

#### **How often should testing be carried out?**

It varies from installation to installation. Recommended intervals advise that academic, commercial and industrial ones are tested every five years\* and domestic ones up to every ten years\*. Although, on very large installations, it can be advantageous to carry out an annual rolling test whereby twenty per cent per year is tested over five years.

#### **What does electrical testing involve?**

Initially, varied site-specific factors need to be identified, accounted for and agreed prior to the examination commencing. This is due to the variations that exist between electrical installations within different buildings, their many uses and the physical and operational restrictions that may exist.

#### **Good housekeeping**

Effective housekeeping can help control or eliminate workplace hazards. Poor housekeeping practices frequently contribute to incidents. If the sight of waste-paper, debris, clutter and spills is accepted as normal, then other more serious hazards may be taken for granted.

Housekeeping is not just cleanliness. It includes keeping work areas neat and orderly, maintaining halls and floors free of slip and trip hazards, and removing of waste materials (e.g.,

paper, cardboard) and other fire hazards from work areas. It also requires paying attention to important details such as the layout of the whole workplace, aisle marking, the adequacy of storage facilities, and maintenance. Good housekeeping is also a basic part of incident and fire prevention.

Effective housekeeping is an on-going operation: it is not a one-time or hit-and-miss clean-up done occasionally. Periodic "panic" clean-ups are costly and ineffective in reducing incidents.

### **Purpose of workplace housekeeping**

Poor housekeeping can be a cause of incidents, such as:

- i. Tripping over loose objects on floors, stairs and platforms
- ii. Being hit by falling objects
- iii. Slipping on greasy, wet or dirty surfaces
- iv. Striking against projecting, poorly stacked items or misplaced material
- v. Cutting, puncturing, or tearing the skin of hands or other parts of the body on projecting nails, wire or steel strapping

To avoid these hazards, a workplace must "maintain" order throughout a workday. Although this effort requires a great deal of management and planning, the benefits are many.

### **Benefits of good housekeeping practices**

Effective housekeeping results in:

- i. Reduced handling to ease the flow of materials
- ii. Fewer tripping and slipping incidents in clutter-free and spill-free work areas
- iii. Decreased fire hazards
- iv. Lower worker exposures to hazardous products (e.g. Dusts, vapours)
- v. Better control of tools and materials, including inventory and supplies
- vi. More efficient equipment clean-up and maintenance
- vii. Better hygienic conditions leading to improved health
- viii. More effective use of space
- ix. Reduced property damage by improving preventive maintenance
- x. Less janitorial work
- xi. Improved morale
- xii. Improved productivity (tools and materials will be easy to find)

### **Good housekeeping program**

A good housekeeping program plans and manages the orderly storage and movement of materials from point of entry to exit. It includes a material flow plan to ensure minimal handling. The plan also makes sure that work areas are not used as storage areas by having

workers move materials to and from work areas as needed. Part of the plan could include investing in extra bins and more frequent disposal.

The costs of this investment could be offset by the elimination of repeated handling of the same material and more effective use of the workers' time. Often, ineffective or insufficient storage planning results in materials being handled many times and being stored in hazardous ways. Knowing the workplace layout and the movement of materials throughout it will help when planning work procedures.

Worker training is an essential part of any good housekeeping program. Workers need to know how to work safely with the products they use. They also need to know how to protect other workers such as by posting signs (e.g., "Wet - Slippery Floor") and reporting any unusual conditions.

Housekeeping order is "maintained" not "achieved." Cleaning and organization must be done regularly, not just at the end of the shift. Integrating housekeeping into jobs can help ensure this is done. A good housekeeping program identifies and assigns responsibilities for the following:

- i. Clean up during the shift
- ii. Day-to-day cleanup
- iii. Waste disposal
- iv. Removal of unused materials
- v. Inspection to ensure cleanup is complete

Do not forget out-of-the-way places such as shelves, basements, sheds, and boiler rooms that would otherwise be overlooked.

The final step to any housekeeping program is inspection. It is the only way to check for deficiencies in the program so that changes can be made. Examples of checklists include inspecting offices and manufacturing facilities.

#### Documentation and reporting

Documentation is about documents, which communicate information. Those documents provide information for and about a certain object, process or topic. Documentation can be published in digital (CD, DVD, disc, memory stick, download, as a web site,) or in analogue (book, paper, poster, photo.) form. Furthermore, digital documentation can be presented in an interactive manner, which increases ease of use. Examples for interactive features are, among others, cross references, search, tip-of-the-day features, contextual information, wizards or knowledge-based help systems.

Another important characteristic of documentation is the level of detail. There may exist several documents describing the same aspect, but are intended for a different audience (with varying domain knowledge) and thus serve a different purpose. Software system underlies continuous



changes throughout their whole life cycle. As a consequence, also the amount of information grows continually. For international software systems, the documentation has to be available in multiple languages. All these aspects contribute to the problems of documentation: Keeping up with changes during the development, propagating changes in requirements documents, design documents to the development and keeping documents on the desired level of quality

### **Maintenance of tools**

When it comes to home improvement tools, regular maintenance tools are mandatory. Only a high-quality tool ensures excellent results and longevity.

As a passionate craftsman, you should know the essential tips about the maintenance of tools and equipment. Machine *maintenance tools* suffer a lot of wear and tear due to regular use.

If you don't do proper maintenance, it may result in machine breakdown and damage. With the proper handling and maintenance, you may reduce any risks. That is why you should do a regular check-up of your machine tools.

### **Basic Tips about Maintenance Tools and Equipment**

#### **Clean the Tools Regularly.**

Whenever you use any tools for your projects, make sure to clean them immediately. The next day, you'll notice there is a layer of dirt that may lead to rust.

That's why you should clean the tools after use. You don't need to use chemicals every time, sometimes wiping is good enough.

#### **Lubricate the Tools.**

Machine tools include moving parts that require lubrication to work smoothly. Check the details daily, whether they are properly lubricated.

Please read the instruction in case of power tools as it requires an adequate level of oil

#### **Sharpen the Essential Parts.**

Some equipment is used for cutting and slicing, such as blade, drill bits, and lathe tools. You'll need to check whether it is sharp or not.

If these tools are not sharp enough, it may result in serious injuries.

#### **Check the Function of the Tools.**

You should check the functions of the tools for any damage or fault. Scrutinize each part.

If any faulty functioning is found, then immediately repair them.

#### **Check Machines Tools, Alignments.**

Most of the time, the machine works with fault due to improper alignment. Improper alignment also affects the tools in a negative way.

So, you should check the arrangement every time you intend to use the tool.

To ensure proper alignment, you may want to perform a few test tasks. If it is working well, that means the machine is all set.

### **Store with Care.**

Proper storing also enhances the lifetime of any machine tools. Moisture and air is the reason for rust over the metal surface of the devices.

You will need to keep the tools in a place that is dry and clean.

If the tools are extensive, keep it in a tight closing garage or dry basement or insulated rooms. Conversely, store the small tools in an air-tight box. Make sure to cover the device and inspect them regularly.

### **Care for Electrical Cords and Batteries.**

The cable wires in some tools are prone to damage. Power tools like circular saw or drill may cut the wires accidentally.

That's why you should keep them protected. You may want to use purpose-built ramps or industrial-strength casing.

If the tool is battery operated, inspect the battery from time to time. Don't let sit it for long. Also, recharge it if needed.

### **Require Decent care of Parts and Accessories.**

It truly is crucial to carry out regular maintenance checks. On each one of your accessories and components. A vitally significant part of perfect maintenance.

It is always to need to take specific most care of your tool's accessories.

And parts have been managed and kept sensibly. You really don't desire to be more careless using almost any component of one's system application.

Good awareness plays a significant role. Use each one you sense to find prospective issues.

A strange noise, an odd scent or unordinary vibration may indicate a problem.

All items which may be easily cared for if discovered early.

Keeping a checklist and logging all of the upkeep completed will maximize the procedure.

### **Storage of tools**

The proper care and storage of tools and equipment are not only the concern of the management but of the workers who use the equipment.

Importance of proper storage of tools and equipment

- i. It is an important factor for safety and health as well as good business.
- ii. Improves appearance of general-shop and construction areas.
- iii. Reduces overall tool cost through maintenance.
- iv. This also ensures that tools are in good repair at hand.
- v. Teaches workers principles of (tool) accountability.

### **Points to consider in storing tools and equipment:**

- i. Have a designated place for each kind of tools.
- ii. Label the storage cabinet or place correctly for immediate finding.
- iii. Store them near the point of use.
- iv. Wash and dry properly before storing.
- v. Store knives properly when not in use with sharp edge down.
- vi. Put frequently used items in conveniently accessible locations.
- vii. Gather and secure electrical cords to prevent entanglement or snagging.
- viii. Cutting boards should be stored vertically to avoid moisture collection.
- ix. Metal equipment can be stacked on one another after drying such as storage dishes and bowls.
- x. Make sure the areas where you are storing the equipment are clean, dry and not overcrowded.

### **Documentation and reporting**

Documentation is about documents, which communicate information. Those documents provide information for and about a certain object, process or topic. Documentation can be published in digital (CD, DVD, disc, memory stick, download, as a web site,) or in analogue (book, paper, poster, photo.) form. Furthermore, digital documentation can be presented in an interactive manner, which increases ease of use. Examples for interactive features are, among others, cross references, search, tip-of-the-day features, contextual information, wizards or knowledge-based help systems.

Another important characteristic of documentation is the level of detail. There may exist several documents describing the same aspect, but are intended for a different audience (with varying domain knowledge) and thus serve a different purpose. Software system underlies continuous changes throughout their whole life cycle. As a consequence, also the amount of information grows continually. For international software systems, the documentation has to be available in multiple languages. All these aspects contribute to the problems of documentation: Keeping up with changes during the development, propagating changes in requirements documents, design documents to the development and keeping documents on the desired level of quality

### **Relevant IEE regulations**

#### **i. Connection of conductors:**

Are terminations electrically and mechanically sound? Is insulation and sheathing removed only to a minimum to allow satisfactory termination?

#### **ii. Identification of conductors:**

Are conductors correctly identified in accordance with the Regulations?

#### **iii. Routing of cables:**

Are cables installed such that account is taken of external influences such as mechanical damage, corrosion, heat, etc.?

iv. **Conductor selection:**

Are conductors selected for current carrying capacity and voltage drop in accordance with the design?

v. **Connection of single pole devices:**

Are single pole protective and switching devices connected in the line conductor only?

vi. **Accessories and equipment:**

Are all accessories and items of equipment correctly connected?

vii. **Thermal effects:**

Are fire barriers present where required and protection against thermal effects provided?

viii. **Protection against shock:**

What methods have been used to attain both basic protection and fault protection?

ix. **Mutual detrimental influence:**

Are wiring systems installed such that they can have no harmful effect on non-electrical systems, or those systems of different currents or voltages are segregated where necessary?

x. **Isolation and switching:**

Are there appropriate devices for isolation and switching correctly located and installed?

xi. **Under voltage:**

Where under voltage may give rise for concern, are there protective devices present?

xii. **Labeling:**

Are all protective devices, switches (where necessary) and terminals correctly labeled?

xiii. **External influences:**

Have all items of equipment and protective measures been selected in accordance with the appropriate external influences?

xiv. **Access:**

Are all means of access to switchgear and equipment adequate?

xv. **Notices and signs:**

Are danger notices and warning signs present?

xvi. **Diagrams:**

xvii. Are diagrams, instructions and similar information relating to the installation available?

xviii. **Erection methods:**

Have all wiring systems, accessories and equipment been selected and installed in accordance with the requirements of the Regulations, and are fixings for equipment adequate for the environment?

So, now that we have inspected all relevant items, and provided that there are no defects that may lead to a dangerous situation when testing, we can start the actual testing procedure.

## Learning Activities

Figure below shows the layout of a consumer intake point and two final circuits.

- i. Draw the wiring diagram and carry out the wiring
- ii. Using PVC mini trunking wiring system install the
  - a) Lighting circuit such that the lamps L1, L2 and L3 are controlled from two different positions.
  - b) Water heater switch to operate the instantaneous shower unit
  - c) Carry out the polarity test

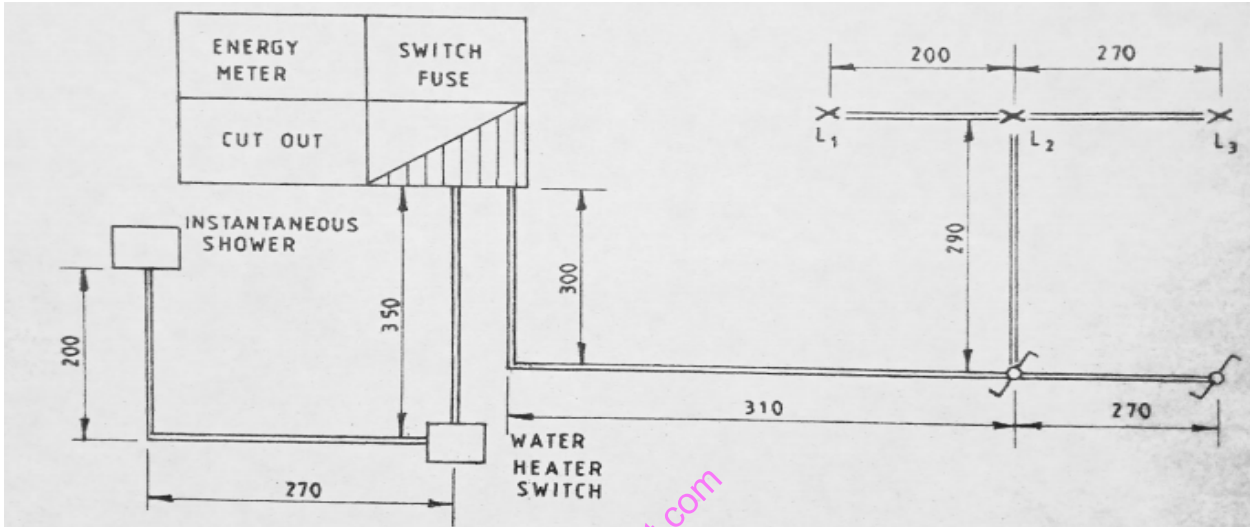

Figure 85: Layout of a Consumer intake point and two final circuits

## Self-Assessment Questions

1. What are the difference between materials and equipment? (1 Mark)
2. What are the examples of equipment? (5 Marks)
3. How do you define equipment? (2 Marks)

## Tools, Equipment, Supplies and Materials

- i. Pliers
- ii. Screwdrivers
- ii. Hammers
- iii. Wire splicers
- iv. Electrician knives
- v. Phase Testers
- vi. Wire gauge
- vii. Wire cutters and strippers
- viii. Steel tapes (draw wire)
- ix. Tape measures

- x. Crimping and clamping tools

## References

- a) <https://drexel.edu/goodwin/professional-studies-blog/overview/2018/July/Five-types-of-communication/>
- b) <https://www.thespruce.com/pull-wire-through-conduit-3969936>
- c) <http://www.btme.co.uk/electricalservices/inspection-testing-of-electrical-installations/>
- d) Brian Scaddan, IEE Wiring Regulations: Inspection, Testing and Certification, Sixth edition, 2008 Elsevier Ltd.

## Model Answers to the self-assessment Questions

### 1. The difference between equipment and materials (1 Mark)

The key difference between equipment and materials is that materials form the actual product and are the parts, components, ingredients and raw materials that become a part of the product whereas equipment refers to the tools, machinery, devices that help create the product.

### 2. Examples of professional equipment (5 Marks)

- i. Personal computers.
- ii. Telefax equipment.
- iii. Typewriters.
- iv. Cameras of all kinds (film and electronic cameras)
- v. Sound or image transmitting, recording or reproducing apparatus (tape and video recorders and video reproducers, microphones, mixing consoles, loudspeakers)
- vi. Sound or image recording media, blank or recorded.

### 3. Equipment (2 Marks)

The set of articles or physical resources serving to equip a person or thing: such as the implements used in an operation or activity: apparatus sports equipment.

All the fixed assets other than land and buildings of a business enterprise can be referred to as equipment.

## 2.3. Install consumer's control unit

### Introduction

The modern consumer unit is the centre, or heart, of the wiring system in the home. The unit distributes the electricity, via fuses of one kind or another, to the different circuits in the house. The older fuse wires are being replaced gradually by their modern equivalent, the MCB or miniature circuit breaker.

### Performance Standard

1. Safety procedures and regulations in installation of Customer's Control Unit
2. Selection of installation tools, equipment and materials
3. Identification and selection of correct PPE for safety in the installation work
4. Identification and selection of consumer's control unit
5. Wiring of consumer's control unit
6. Cleaning up of workplace and OSH regulations

### Information Sheet

#### Meaning of power intake point

The electricity supply to a domestic installation begins at the meter cabinet which houses the DSO service fuse, DSO meter and an isolator. This is the Main Supply Point.

The DSO supply cable is referred to as the service cable. The DSO service fuse and meter are sealed to prevent any interference with this part of the installation. The Nominal Voltage of the supply to domestic premises is 230 Volts. This is known as Low Voltage.

#### Identification of sequence of control equipment

The control and distribution of the electricity supply to the installation is contained within one enclosure. It is referred to as a Distribution Board. This unit has its own main switch fuse, or a separate main switch and main fuse, or main MCB. This is followed by individual circuit fuses or more commonly nowadays, Miniature Circuit Breakers (MCB's), to protect and isolate each circuit. There will also be neutral and earth terminals provided.

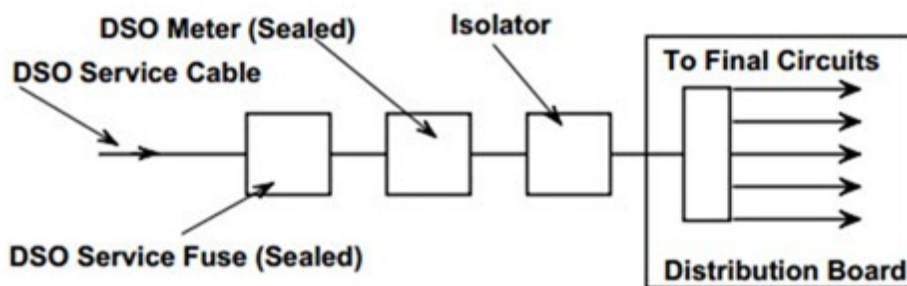

Figure 86: Neutral and Earth terminals

## Distribution Board

The distribution board may also house other protective or control devices such as Residual Current Devices (RCD's), bell transformers, time-switches and contactors.

Figure below represents the sequence of control for a very basic distribution board. Depending on the installation requirements, a second or third RCD may be required and of course, more MCB's, one for each circuit.

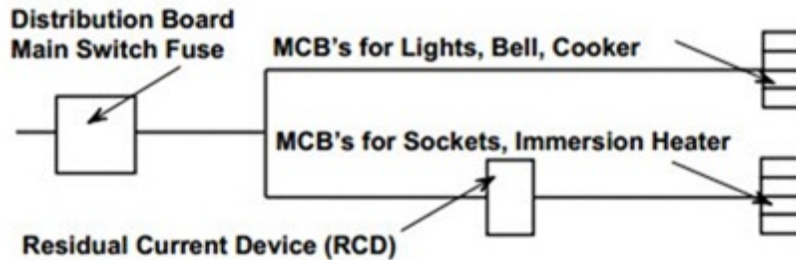

Figure 87: Sequence of Control for a very basic distribution board

As can be seen, an RCD is not provided for the lighting and cooker circuits, although there are exceptions to this situation.

### Mounting of components

- i. An assemblage comprising an electrical component mounting panel of sheet metal having a plurality of teeth struck therefrom to extend in a generally normal direction to one side of the plate and leaving a plurality of slots in said plate from which said teeth are struck, an electrical component, and means for securing said electrical component to said plate including a screw engaging said component and threadedly received in one of the slots in said plate, a backing panel, said plate being disposed against said backing panel with the tips of said teeth bearing against said backing panel, and means for securing said plate to said backing panel including screws threadedly engageable in said slots.
- ii. An assemblage comprising a mounting panel according to claim 1 wherein the latter screws engage through said plate from a side thereof opposite the side from which the first mentioned screw engages through the plate.
- iii. An assemblage including a mounting panel according to claim 1 including an enclosure for said electrical components, said backing panel comprising one wall of said enclosure.



- iv. An assemblage including a mounting panel according to claim 1 including a plurality of electrical components, means for securing each component to said plate including screws engaging said components and threadedly received in the slots of said plate, the screws securing said plate to said backing panel engaging through said plate from a side thereof remote from said electrical components.

### **Wiring of intake point**

Main Distribution Board or Fuse Boards (Consumer Unit) usually contains on the following three main units to control and distribute electric supply to the different connected appliances and devices through electrical wiring cables and wires.

### **Earth lead and earth electrode installation**

The quality of an earth electrode (resistance as low as possible) depends essentially on two factors:

- i. Installation method
- ii. Type of soil

Three common types of installation will be discussed:

#### **Buried ring**

This solution is strongly recommended, particularly in the case of a new building.

The electrode should be buried around the perimeter of the excavation made for the foundations. It is important that the bare conductor be in intimate contact with the soil (and not placed in the gravel or aggregate hard-core, often forming a base for concrete). At least four (widely-spaced) vertically arranged conductors from the electrode should be provided for the installation connections and, where possible, any reinforcing rods in concrete work should be connected to the electrode.

The conductor forming the earth electrode, particularly when it is laid in an excavation for foundations, must be in the earth, at least 50 cm below the hard-core or aggregate base for the concrete foundation. Neither the electrode nor the vertical rising conductors to the ground floor, should ever be in contact with the foundation concrete.

For existing buildings, the electrode conductor should be buried around the outside wall of the premises to a depth of at least 1 metre. As a general rule, all vertical connections from an electrode to above-ground level should be insulated for the nominal LV voltage (600-1,000 V).

The conductors may be:

- i. Copper: Bare cable ( $\geq 25 \text{ mm}^2$ ) or multiple-strip ( $\geq 25 \text{ mm}^2$ ) and ( $\geq 2 \text{ mm}$  thick)

- ii. Aluminium with lead jacket: Cable ( $\geq 35 \text{ mm}^2$ )
- iii. Galvanised-steel cable: Bare cable ( $\geq 95 \text{ mm}^2$ ) or multiple-strip ( $\geq 100 \text{ mm}^2$  and  $\geq 3 \text{ mm}$  thick)

The approximate resistance R of the electrode in ohms:

$$R = \frac{2\rho}{L}$$

Where,

**L**

= length of conductor in meters

**$\rho$**

= resistivity of the soil in ohm-metres (see [Influence of the type of soil](#))

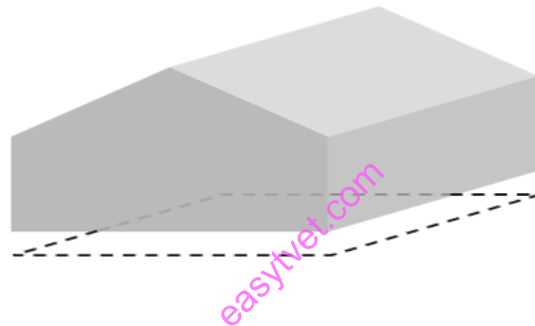

Figure 88: Conductor buried below the level of the foundation

### Earthing rods

$$\text{For } n \text{ rods: } R = \frac{1}{n} \frac{\rho}{L}$$

ally driven earthing rods are often used for existing buildings, and for improving (i.e., reducing the resistance of) existing earth electrodes.

The rods may be:

- i. Copper or (more commonly) copper-clad steel. The latter are generally 1 or 2 meters long and provided with screwed ends and sockets in order to reach considerable depths, if necessary (for instance, the water-table level in areas of high soil resistivity)
- ii. Galvanized steel pipe  $\geq 25 \text{ mm}$  diameter or rod  $\geq 15 \text{ mm}$  diameter,  $\geq 2$  meters long in each case.

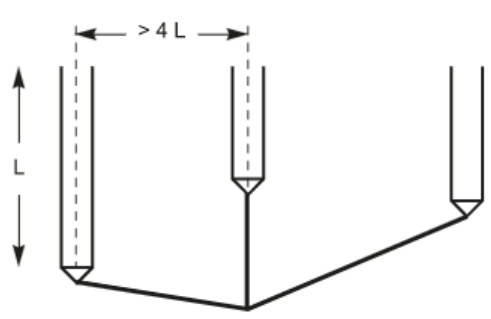

Figure 89: Earthing rods connected in parallel

It is often necessary to use more than one rod, in which case the spacing between them should exceed the depth to which they are driven, by a factor of 2 to 3.

The total resistance (in homogeneous soil) is then equal to the resistance of one rod, divided by the number of rods in question.

The approximate resistance  $R$  obtained is:

$$R = \frac{1}{n} \frac{\rho}{L}$$

If the distance separating the rods  $> 4L$

Where,

$L$  = the length of the rod in meters

$\rho$  = resistivity of the soil in ohm-metres (see Influence of the type of soil)

### Vertical plates

$$\text{For a vertical plate electrode: } R = \frac{0.8 \rho}{L}$$

Rectangular plates, each side of which must be  $\geq 0.5$  metres, are commonly used as earth electrodes, being buried in a vertical plane such that the centre of the plate is at least 1 metre below the surface of the soil.

The plates may be:

- i. Copper of 2 mm thickness

- ii. Galvanized steel of 3 mm thickness

The resistance  $R$  in ohms is given (approximately), by:  $R = \frac{0.8 \rho}{L}$

Where

$L$  = the perimeter of the plate in metres

$\rho$  = resistivity of the soil in ohm-metres (see Influence of the type of soil)

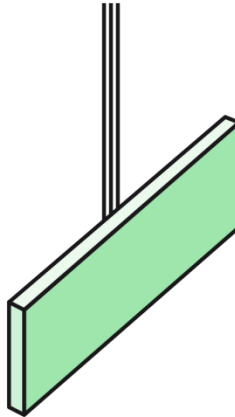

Figure 90: Vertical plate

### Bonding of all metal parts

- a) Extraneous-conductive-part: A conductive part liable to introduce a potential, generally earth potential, and not forming part of the electrical installation.

For example:

- i. Non-insulated floors or walls, metal framework of buildings
- ii. Metal conduits and pipework (not part of the electrical installation) for water, gas, heating, compressed-air, etc. and metal materials associated with them

**Bonding conductor:** A protective conductor providing equipotential bonding

**Main earthing terminal:** The terminal or bar provided for the connection of protective conductors, including equipotential bonding conductors, and conductors for functional earthing, if any, to the means of earthing.

### The main equipotential bonding system

The bonding is carried out by protective conductors and the aim is to ensure that, in the event of an incoming extraneous conductor (such as a gas pipe, etc.) being raised to some potential due to a fault external to the building, no difference of potential can occur between extraneous-conductive-parts within the installation.

The bonding must be affected as close as possible to the point(s) of entry into the building, and be connected to the main earthing terminal (6).

However, connections to earth of metallic sheaths of communications cables require the authorization of the owners of the cables.

### **Supplementary equipotential connections**

These connections are intended to connect all exposed-conductive-parts and all extraneous-conductive-parts simultaneously accessible, when correct conditions for protection have not been met, i.e., the original bonding conductors present an unacceptably high resistance.

### **Connection of exposed-conductive-parts to the earth electrode(s)**

The connection is made by protective conductors with the object of providing a low-resistance path for fault currents flowing to earth.

### **Provision of draw wire for power authority**

A **fish tape** (also known as a *draw wire* or *draw tape* or an "electricians snake") is a tool used by electricians to route new wiring through walls and electrical conduit.

### **Conducting final checks for workmanship, conformity with instructions and job requirements**

In general terms we are inspecting the installation with regard to personal safety, equipment age, deterioration, equipment corrosion and overload.

Suitability and external influence to the power system should also be included. At this point it is a good idea to get from the client any documentation that is relevant to the installation (like plans, drawings, previous test results and certification/if any, fuse charts and so on.

You should also make it clear that you will require access to all parts of the building and that the electricity supply will need to be turned off at some point. It is also a good idea to ask the client if they are aware of any alterations that have been carried out, as this information may be useful to you during inspection.

### **Good housekeeping**

#### **The elements of an effective housekeeping program**

- i. Maintenance. The maintenance of buildings and equipment may be the most important element of good housekeeping.
- ii. Dust and Dirt Removal.
- iii. Maintain Light Fixtures.
- iv. Aisles and Stairways.

- v. Spill Control.
- vi. Tools and Equipment.

### **Maintenance of tools**

The following are some helpful tips on how to clean and properly store your tools.

- i. Keep Power Tools Clean. **Dust** and grime can bring your power tools to a grinding halt if left unchecked over time
- ii. Store Power Tools Correctly.
- iii. Inspect for Wear or Damage.
- iv. Lubricate Moving Parts.
- v. Keep Batteries in Shape.

### **Storage of tools**

Zip those home projects out in no time with well-organized and properly stored tools and other home maintenance equipment. Garden supplies, vehicle implements and liquids and home tools such as hammers, saws, nails and power equipment all benefit from proper care and storage. These items organized efficiently make home projects easy, and make clean up even easier.

### **Documentation and reporting**

Documentation is anything written or printed on which you rely as record or proof of patient actions and activities. A record or chart or client record, is a formal, legal document that provides evidence of a client's care and can be written or computer based.

### **Learning Activities**

Figure below shows the layout of the equipment at consumer's intake point and two final circuits.

- a) Draw the wiring diagram of the installation
- b) Carry out the wiring at the consumer intake point
- c) Using PVC sheathed wiring system install the
  - i. Lighting circuit such that switch S1 controls lamp L1 and L2 and switch S2 controls L2
  - ii. Cooker control unit and the cooker terminal box.
- d) Carry out the insulation test

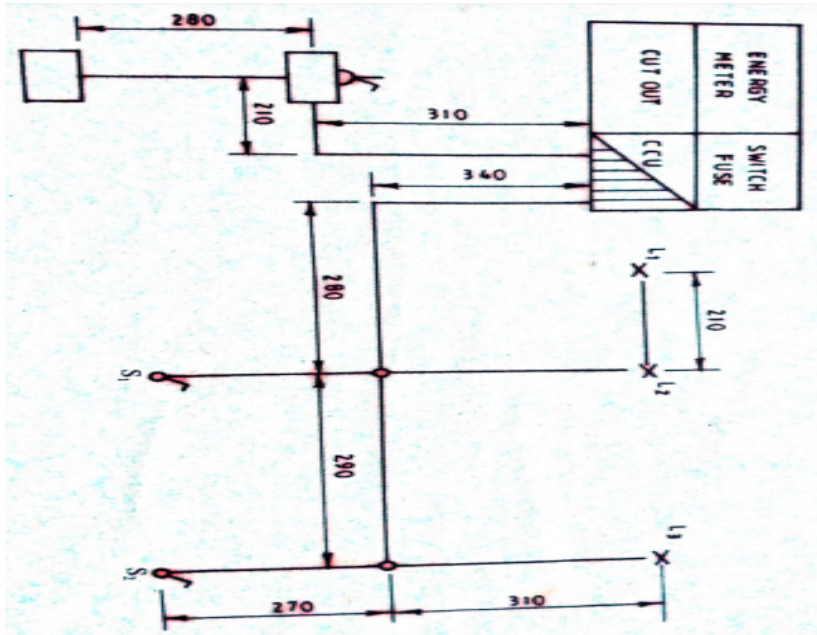

Figure 91: Consumer's Intake Point

### Self-Assessment

1. Is an earth wire dangerous?
2. How is earthing connected?
3. What happens if there is no earthing?
4. What is the purpose of earthing?
5. How would you fix surface mount components?

### Tools, Equipment, and Materials

- i. Tape Measure.
- ii. Hammer.
- iii. Torpedo Level.
- iv. Flashlight.
- v. Utility Knife.
- vi. Screwdrivers.

### References

- i. <http://machineryequipmentonline.com/electric-equipment/lighting-circuitssequence-of-control/>
- ii. [https://www.electrical-installation.org/enwiki/Installation\\_and\\_measurements\\_of\\_earth\\_electrodes](https://www.electrical-installation.org/enwiki/Installation_and_measurements_of_earth_electrodes)
- iii. [https://www.youtube.com/watch?v=o6M7769TymU&feature=emb\\_title](https://www.youtube.com/watch?v=o6M7769TymU&feature=emb_title)

### Model Answers to self-assessment Questions

(2 Marks)

1. Earthing. Without the earth wire, if a fault occurs and the live wire becomes loose, there is a danger that it will touch the case. The next person who uses the appliance could get electrocuted. As the wire is made of copper, the earth wire provides a low resistance path to the ground.
2. Connectors for earthing installation are a means of communication between the various components of the earthing and lightning protection installations (earthing rods, earthing conductors, current leads, busbars, etc.). For high voltage installations, exothermic welding is used for underground connections. (2 Marks)  
(1 Mark)
3. If the house is not earthed, people could get electrocuted. Without an earth connection, the safety switches will not work and an electrical fault could cause a house or appliances to become 'live' as the current flows to earth.
4. Earthing is used to protect you from an electric shock. It does this by providing a path (a protective conductor) for a fault current to flow to earth. It also causes the protective device (either a circuit-breaker or fuse) to switch off the electric current to the circuit that has the fault.
5. Steps: (5 Marks)  
**Step 1:** Preparing the PCB. Check to be sure the pad size of the PCB lines up with the pins on the SMD.  
**Step 2:** Use Tweezers to Position the Component.  
**Step 3:** Tack Down One Corner.  
**Step 4:** Flux.  
**Step 5:** Solder.  
**Step 6:** Heat Up Desoldering Wick to Fix Tack.  
**Step 7:** Solder.  
**Step 8:** Fix Any Remaining Solder Bridges.

## 2.4. Inspect and test the complete installation

### Introduction

It is a vital part of every electrical job and is completely separate to Part. An inspection and test is carried out to verify, so far as is reasonably practicable, that the requirements of BS 7671 (Wiring Regulations) and other relevant regulations have been met, during the job itself and after completion before handing over to the client. Inspection and testing should also be carried out for all electrical installations at regular intervals. For example, an EICR (Electrical Installation Condition Report) for existing installations.

### Performance Standard



1. The process of electrical inspection and testing
2. Visual and physical checks
3. Verification of polarity test on an electrical installation
4. Types of electrical installation tests
5. Testing equipment and tools
6. Good housekeeping
7. Maintenance of tools and equipment
8. Documentation and reporting

## Information Sheet

### Meaning of inspection and testing

Inspection and Testing is the testing procedures that electricians use to ensure that a circuit is working correctly and safe for use before being energised. Inspection and testing should also be carried out for all electrical installations at regular intervals.

### Sections of the installation to be inspected

The following items must be checked concerning protection against direct contact:

- i. Insulation of live parts
- ii. Enclosures have a suitable degree of protection appropriate to external influences
- iii. Enclosures have cable entries correctly sealed
- iv. Enclosures have unused entries blanked off where necessary

### Types of visual and physical checks

A visual electrical inspection is a survey of your electrical wiring system. It is used to identify defects, damage or deterioration of the electrical installation and to determine whether it complies with the current BS7671 electrical safety standard. This type of inspection does not involve any circuit testing, therefore, on its own.

### Completion installation tests

It is through this certification system that Safe Electric, can monitor and validate that the electrical works completed meet the required safety standards (National Rules for Electrical Installations).

To facilitate the wide range of electrical works undertaken by RECs, the different types of Completion Certificates are outlined below:

**Certificate No. 1 (paper based) (<50 kVA):** Completion Certificate for the connection of new electrical installations (less than 50kVA) to the Distribution System Operator (DSO) Network. A sample for an Electronic Certificate No. 1 is available [here](#).

**Certificate No. 2 (paper based) ( $\geq 50$  kVA):** Completion Certificate for the connection of new electrical installations (greater than or equal to 50kVA) to the DSO Network. A sample for an Electronic Certificate No. 2 is available [here](#).

**Certificate No. 3:** Covers alterations (including additions and extensions) to existing installations. Certificate No. 3 cannot be used to obtain a connection or a re-connection of the electrical supply from the DSO.

**Agricultural Certificate:** All electrical works in agricultural locations must comply with the National Rules for Electrical Installations. A copy of the Agricultural Completion Certificate may be required by the Department of Agriculture for agricultural buildings grant-aid.

**Interim electrical installations ( $\geq 50$ kVA):** Interim Certificates are validated by Safe Electric to enable the main distribution board in an industrial or commercial installation to be energised so that a completed subsystem e.g. a lift system, or a standalone module, can be tested or commissioned.

### **Verification of polarity test**

This test will verify that all the switches installed in the system are connected in current carrying conductor and not in neutral. For example, if you isolate or switch the neutral of a circuit via a single-pole circuit breaker or switch, it would appear that the circuit is dead where in fact it is still live.

### **Insulation**

A Quality Insulation Inspection (QII) is performed by a certified HERS (Home Energy Rating System) technician. This inspection ensures that the insulation in a home is installed to a particular standard set by the California Energy Commission.

### **Resistance test**

The Insulation Resistance Test is the second test required by the electrical safety testing standards. The Insulation Resistance Test consists in measuring the Insulation resistance of a device under test, while phase and neutral are short circuited together. This is the simplest of the tests.

After the required connections are made, you apply the test voltage for a period of one min. (The one-min interval is an industry practice that allows everyone to take the reading at the same time. In this way, comparison of readings will be of value because, although taken by different people, the test methods are consistent.) During this interval, the resistance should drop or remain relatively steady.

Larger insulation systems will show a steady decrease, while smaller systems will remain steady because the capacitive and absorption currents drop to zero faster on smaller insulation systems. After one min, read and record the resistance value.

Note that IR is temperature sensitive. When the temperature goes up, IR goes down, and vice versa. Therefore, to compare new readings with previous readings, you need to correct the readings to some base temperature. Usually, 20°C or 40°C are used as comparison temperatures; tables are available for any correction. However, a common rule of thumb is that IR changes by a factor of two for each 10°C change.

### **Earth continuity tests**

The earth continuity test is a designed to test the resistance of the protective earth of an appliance and/or the supply lead. It is measured between any accessible earthed parts and the earth pin of the plug. The test is based on the principles of Ohm's Law.

### **Ring circuit continuous test**

It is very important that each of the three rings associated with each circuit (phase, neutral and protective conductors) should be continuous and not broken. In simple terms, current is then shared between the conductors, so that each could have a minimum current carrying capacity of 15 A.

### **Learning Activities**

In a construction site, a team of electrician carries out electrical installation for both lighting and power circuits. During inspection it noticed that the lighting circuit is not working. As an electrician, inspect and test the whole lighting circuit.

### **Self-Assessment Questions**

1. Which instrument is used to test the new wiring installation? **(2 Marks)**
2. How many types of electrical measuring instruments are there? **(4 Marks)**
3. What is inspection in electrical installation? **(2 Marks)**
4. How do you test electrical equipment? **(5 Marks)**
5. How often should electrical testing be done? **(2 Marks)**

### **Tools, Equipment, and Materials**

- i. Continuity **tester**.
- ii. Insulation resistance **tester**.
- iii. Earth fault loop impedance **tester**.
- iv. RCD **tester**.

### **References**

- i. <https://safeelectric.ie/help-advice/completion-certificates/>
- ii. <https://www.ecmweb.com/maintenance-repair-operations/test-measurement/article/20898954/understanding-insulation-resistance-testing>

### Model Answers to self-assessment Question

1. Instruments used to test the new wiring installation

a) Meg ohmmeters

**(2 Marks)**

Megohmmeters assess high electrical resistance and are used to test motor winding, cable assemblies, and insulation, wiring installations, motors, transformers generators, and more.

2. List of electrical and electronic measuring equipment:

**(4 Marks)**

- (i) Ammeter (Amperemeter):- Measures current
- (ii) Capacitance meter:- Measures the capacitance of a component
- (iii) Current clamp:- Measures current without physical connection
- (iv) Curve tracer:- Applies swept signals to a device and allows display of the response

3. Inspection

**(2 Marks)**

This is an examination of an electrical installation using all available means to ascertain correct selection and proper erection of electrical equipment.

Note: the word 'inspection' has replaced 'visual inspection', indicating that all of the senses (touch, hearing, and smell, as well as sight) must be used.

4. The correct tests need to be carried out on your Class I or Class II appliance in the following order:

**(5 Marks)**

- (i) Visual Inspection.
- (ii) Earth Continuity Test.
- (iii) Insulation Resistance Test.
- (iv) Leakage Test.

Further tests have to be performed on leads, RCDs etc.

5. For many commercial businesses, an EICR, which used to be called a periodic testing report, will be required at the lowest frequency interval – every 5 Years. However, higher risk environments will require 3 Yearly or even more frequent testing. It should be noted that all stated periods are maximum intervals.

**(2 Marks)**

## 2.5.Repair and maintain the installation

### Introduction

The technical meaning of **maintenance** involves functional checks, servicing, repairing or replacing of necessary devices, equipment, machinery, building infrastructure, and supporting

utilities in industrial, business, governmental, and residential installations. Over time, this has come to include multiple wordings that describe various cost-effective practices to keep equipment operational; these activities occur either before or after a failure.

### **Performance Standard**

1. Safety procedures and regulation in the repair and maintenance of electrical systems
2. Tools, equipment and materials used in repair and maintenance
3. Identification and replacement of faulty components
4. Routine checks on an electrical installation
5. Repair and replacements of faulty components

### **Information Sheet**

#### **Meaning of repair and maintenance**

Repairs are restoration work for when something gets broken, damaged or stops working. Maintenance are routine activities meant to prevent damage and prolong the life of appliances, fixtures, and the property itself. Examples include regular cleaning of air-conditioning units, grease traps, repainting, and the likes.

#### **Types of maintenance**

- i. Routine
- ii. Breakdown
- iii. Periodic
- iv. Overhaul

easyvet.com

#### **Maintenance procedures**

- i. Conducting final checks for workmanship, conformity with instructions and job requirements
- ii. Good housekeeping
- iii. Maintenance of tools
- iv. Storage of tools
- v. Documentation and reporting
- vi. Relevant IEE regulations

#### **Routine maintenance**

Routine maintenance refers to any maintenance task that is done on a planned and ongoing basis to identify and prevent problems before they result in equipment failure. Some common routine maintenance includes regular inspections or service work.

#### **Breakdown maintenance**

Breakdown maintenance is maintenance performed on a piece of equipment that has broken down, faulted, or otherwise cannot be operated.

## **Periodic maintenance**

Periodic maintenance refers to activities performed on equipment based on a set time interval. The purpose of periodic maintenance, or time-based maintenance, is to maintain smooth operation of a machine or other asset.

## **Overhauling maintenance**

Overhauling of a machine is defined as a process of general maintenance performed on a machine or other industrial equipment. The goal of overhauling is to keep the system in serviceable condition.

## **Repair and replacements of faulty components**

When equipment breaks down, everything from your productivity to your bottom line is disrupted. Your team needs a quick and effective solution. The difficult question arises- should you try for a repair, or replace the asset outright?

Replacing equipment is the larger investment; so many technicians choose to repair the equipment instead of replacing it. But the costs that go along with frequent breakdowns — lower productivity, defective output, rising labour costs, and unmet production schedules — can sometimes be greater than the cost of replacing the equipment outright.

In addition to the obvious replacement cost for a new piece of equipment, there are several other factors to take into consideration when deciding whether to repair or replace a piece of equipment:

- i. Ongoing maintenance costs over the remaining life of the equipment
- ii. The impact any repair would have on productivity and quality
- iii. Costs incurred from the equipment downtime
- iv. Health, safety, and environmental costs that come with equipment breakdown
- v. Training costs for a new piece of equipment
- vi. Disposal costs
- vii. Installation costs

## **Maintenance procedures**

Maintenance procedures are written instructions that, when followed by the maintenance personnel, will ensure that equipment operates as designed within safe operating limits.

- a) Maintenance procedures that should be considered when preparing the planned maintenance program include:

- b) Carrying out repairs needed when plant or equipment breaks down;
- c) Predicting, from a history of breakdowns, the life expectancy of parts, bearings, etc., the tasks to be carried out and the frequency to be established;
- d) Checking the condition throughout the plant of equipment, its running hours, readings of different responses (e.g. vibration, temperatures, current, etc.);
- e) Monitoring the operating cycle and, where appropriate, seasonal shutdowns of plant, equipment (e.g. production process, 24-hour duty, etc.).

### Learning Activities

Assume you are the lead technician in a production a company where one of the production machine stops working. As a qualified electrician perform the following maintenance:

- i. Routine
- ii. Breakdown
- iii. Periodic
- iv. Overhaul

### Self-Assessment

- |  |           |
|--|-----------|
| 1. What are the four types of maintenance?               | (3 Marks) |
| 2. What is a maintenance checklist?                      | (2 Marks) |
| 3. What is difference between maintenance and repair?    | (4 Marks) |
| 4. What is the purpose of machine overhauling?           | (3 Marks) |
| 5. Which process comes under the periodical maintenance? | (3 Marks) |

### Tools, Equipment and Materials

- i. Pliers. Pliers—often referred to as cutting pliers or lineman pliers—are a staple on any **electrical tools** list.
- ii. Screwdrivers.
- iii. **Electrical** Contractor Software.
- iv. Tape Measure.
- v. **Electrical** Tape.
- vi. Cable Ties.
- vii. **Electric** Drill.

### References

- i. <https://www.micromain.com/asset-repair-or-replace/>

- ii. <https://www.sciencedirect.com/topics/engineering/maintenance-procedure#:~:text=Maintenance%20procedures%20are%20written%20instructions,designed%20within%20safe%20operating%20limits.>

## **Model Answers to Self-Assessment Questions**

### **1. Types of maintenance**

(3 Marks)

Four general types of maintenance philosophies can be identified, namely:

- i. Corrective,
- ii. Preventive,
- iii. Risk-based and
- iv. Condition-based maintenance.

### **2. Maintenance Checklist.**

(2 Marks)

An itemized list of discrete maintenance tasks that have been prepared by the manufacturers of the asset and/or other subject matter experts such as consultants. Checklists are the basic building blocks of a maintenance program. Organization of the Checklist.

### **3. Difference between Maintenance and Repair**

(4 Marks)

Maintenance is regular service that will help prolong the life of your vehicle, while auto repair is when a part or fluid is not performing and needs to be fixed. Without proper maintenance, pricey repairs might be needed.

### **4. Purpose of machine overhauling**

(3 Marks)

When a machine is overhauled, it is disassembled, cleaned, inspected, and repaired as necessary. Depending on what the issue is with your engine, sometimes an overhaul is better than if you would fully replace it. This can also save you money and you will not need a brand new machine for your vehicle.

### **5. Periodic maintenance schedule**

(3 Marks)

Periodic maintenance schedule is a time-based series of activities performed on equipment to maintain the smooth operation of the vehicle. Wear and tear is unavoidable and motor vehicles would usually have a long life span before eventually being unoperational.



## **CHAPTER THREE: FIXING AND MAINTENANCE OF LIGHT FITTINGS, POWER OUTLETS AND BASIC APPLIANCES**

**Unit Code:** ENG/LG/EI/CR/03/3/A

**Related Unit of Competency in Occupational Standard:** Perform fixing and maintenance of light fittings, power outlets, and basic appliances

### **Introduction to the unit of learning**

This unit of learning provides insight into the maintenance requirements for over current protective devices and the potential impact on the arc flash incident energy when maintenance is not performed properly.

Electrical preventive maintenance and testing is one of the most important functions to be performed in order to maintain the reliability and integrity of electrical distribution systems, as well as for the protection of equipment and personnel. However, preventive maintenance of electrical systems and equipment, specifically with regard to over current protective devices is often overlooked, or is performed infrequently or inadequately. An unintentional time delay in the operation of a circuit breaker, due to a sticky operating mechanism, can cause the incident energy of an arc flash to rise, sometimes dramatically.

The National Electrical Code (NEC) states that over current protection for conductors and equipment are provided to open the circuit if the current reaches a value that will cause an excessive or dangerous temperature in conductors or conductor insulation. With regard to circuit breakers the only way to accomplish this is through proper maintenance and testing of these devices, per the manufacturer's instructions.

### **Summary of Learning Outcomes**

1. Apply workplace safety
2. Select wiring devices
3. Install wiring devices, lighting fixtures and basic appliances
4. Perform basic repair and maintenance of installation and appliances.

### 3.0. Apply workplace safety

#### Introduction

Workplace safety is one of the most important considerations you should take before any installation project gets underway. Health and safety in installation are particularly important because the sites are prone to hazardous situations and can be dangerous at times.

#### Performance Standard

1. Meaning, importance and types of PPE
2. Safe and correct handling, use, maintenance and storage of different types of PPE
3. Occupational risks e.g., falling from heights, bites from insects, cuts

#### Information Sheet

##### Meaning of term PPE

Personal protective equipment (PPE) is protective clothing, helmets, goggles, or other garments or equipment designed to protect the wearer's body from injury or infection. The hazards addressed by protective equipment include physical, electrical, heat, chemicals, bio hazards, and airborne particulate matter.

##### Purpose of PPE

In the hierarchy of risk control, PPE is considered to rank lowest and represent the option of last resort. It is only appropriate where the hazard in question cannot be totally removed or controlled in such a way that harm is unlikely (for example by isolating the hazard or reducing the risk at source to an acceptable level).

##### Types of PPE

Various types of PPE are available for use in the workplace. The healthy and safety executive provides guidance and general information about types of PPE used in industry, but it doesn't cover specialized and less-used items.

Detailed information should be obtained from suppliers on these more specialized items. Potential users should be involved in the selection of equipment they will be expected to wear and if possible, more than one model should be made available to them.

##### The different types of PPE include:

- i. Head and scalp protection;
- ii. Respiratory protection;

- iii. Eye protection;
- iv. Hearing protection;
- v. Hand and arm protection;
- vi. Foot and leg protection
- vii. Body protection;
- viii. Height and access protection.

### **Head and scalp protection**

There are five primary purposes of head protection, to protect:

- i. The head in falls;
- ii. Against falling objects, impact with fixed objects, or wielded weapons;
- iii. The head by offering thermal insulation;
- iv. Against entanglement and laceration to the head;
- v. Against scalping/entanglement particularly on machinery where injuries are still numerous. Hair-nets and caps are also used for hygiene reasons.

All forms of head and scalp protection must be suitable, correctly fitted and have an easily adjustable headband, nape and chin strap where appropriate. The relevant standards are BS EN 397 and BS EN 14052.

### **Eye protection**

PPE for the eyes is intended to provide protection against impact, cuts, splashes, mists and sprays. The relevant standards are BS 7028 (Guide to Selection of Eye Protection for Industrial and Other Uses) and BS EN 166 (Specification for Eye Protectors).

All PPE must be regularly cleaned, but this is especially important in the case of eye protection as dirty lenses lead to poor vision and may contribute to accidents.

Where lenses become scratched, pitted or cracked they should be replaced.

Users who need to wear corrective lenses (glasses) should have this requirement accommodated in the provision of the PPE to them e.g. as protective over glasses where appropriate, or in the form of prescription lenses if necessary. Where they may be required to wear eye protection on a regular and prolonged basis than any goggles, safety-glasses etc. should meet the user's prescription requirements.

### **Hearing protection**

Assessments carried out under the 'Control of Noise at Work Regulations 2005' will determine whether personal ear protectors are required in the workplace or not, and the noise attenuation required. The relevant standard for the ear protectors is BS EN 352 Part 1.

In providing hearing protection, employers should select protectors which are suitable for the working environment and should consider how comfortable and hygienic they are. Like other PPE, hearing protection will need to be compatible with other PPE (eg hard hats, dust masks and eye protection) worn by workers.

Employers may also wish to provide a range of protectors to allow employees to choose ones which suit them.

Bearing mind that the theoretical attenuation is rarely achieved and it is therefore necessary to over-specify the protection. When selecting hearing protection, use the detailed noise assessment to determine the attenuation required at High, Medium and Low frequencies and match this against suitable products. Bear in mind that where ear plugs are used, training will be needed to ensure that they are used correctly. Where ear defenders are used it should be ensured that users do not use music headphones or buds simultaneously. For high noise environments, it may be appropriate to specify both plugs and defenders.

### **Hand and arm protection**

Most work requires a degree of manual dexterity and consequently the hands are exposed to a wide range of hazards. Risks include cuts, abrasions, heat, cold, chemical contamination, vibration, burns, infection, skin irritation and dermatitis.

Before selecting hand and arm protection, the hierarchy of control measures must be followed. Gloves and gauntlets provide the main form of hand protection against a range of industrial hazards, but other forms of PPE such as mitts, wrist cuffs or armlets may also be used.

In the case of manual handling where there may be a risk of piercing by abrasive, sharp or pointed objects, gloves should be provided where these hazards cannot otherwise be removed, isolated or reduced to an acceptable level. Such gloves are usually made from leather, chain mail, rubber, knitted Kevlar or stout canvas. However, gloves should not normally be worn where there is a risk of them being caught in machinery.

Where chemical exposure is a hazard, and the risk extends to contact with the arms, gauntlets should be specified rather than gloves.

BS EN 14328 is the standard for gloves and arm guards protecting against cuts by powered knives while BS EN 407 contains the specifications for gloves intended to protect against

thermal risk such as heat and/or fire. BS EN 374 Part 1 covers gloves for protection against chemicals and microorganisms. BS EN 511 covers gloves for protection against the cold. BS EN 388 covers the specification of gloves against mechanical hazards.

### **Foot and leg protection**

A wide range of safety footwear is available providing protection against many hazards to the feet or legs including crushing, slipping, piercing, temperatures, electricity, chemicals, cutting, and chopping. The relevant standard for safety footwear is BS EN ISO 20345. BS EN ISO 17249:2004 is the standard for chainsaw footwear. Depending on the hazard various PPE options may be appropriate including safety boots and shoes with protective toe caps and penetration-resistant mid-sole; gaiters; leggings; and spats.

### **Body protection**

The Regulations' definition of PPE excludes ordinary working clothes and uniforms which have no specific protection for the wearer. However, body protection may be required for extended periods of work outdoors to protect against the weather, and to ensure high visibility during work where there is mixed vehicle and pedestrian traffic (see BS EN 471 + A1 'High-visibility Warning Clothing for Professional Use').

PPE for the body may also be required where workers are exposed to extremes of temperature (whether outdoors or indoors), as well as chemical or metal splash, spray from pressure leaks or spray guns, impact or penetration, contaminated dust, excessive wear, entanglement of own clothing or the risk of drowning.

When choosing body protection, the following factors should be considered:

- i. Thermal comfort, for example, due to sweating;
- ii. Cost and practicality of cleaning;
- iii. Emergency procedures, such as buoyancy or the need to be identified or spotted in hazardous situations;
- iv. Level of hygiene control required;
- v. Level of personal contamination;
- vi. Personal preference;
- vii. Restriction of movement;
- viii. Storage;
- ix. Temperature and humidity fluctuation;
- x. Whether the worker is involved in a process that is wet or dry.

### **Respiratory protection**

This covers equipment ranging from breathing apparatus and positive pressure powered respirators through to protective hoods, close-fitting full-face respirators, half mask respirators and disposable face masks. It is always essential to select the correct equipment both for the risk and the individual and to ensure there is adequate training in its use. It should be noted that the only form of respiratory protection which is suitable for work in a confined space is breathing apparatus, as other forms of respiratory protection do not provide a source of air or oxygen. Face fit testing requirements apply to all close-fitting respirators.

### **Height and access protection**

This range of protective equipment is very wide and includes body harnesses, fall-arrest systems, rescue lifting and lowering harnesses, energy Absorbers and lanyards.

Such PPE is specialized and requires thorough training by competent persons, in user checks as well as correct use.

Equipment will require periodic inspection by a competent person and anchorage points will normally require periodic testing.

### **Skin care: 'Barrier' creams**

Some occupations are prone to skin disease caused by contact with substances such as cutting oils; chemicals, depressants, glass-fiber and some horticultural agents (e.g. slug pellets). The main condition is dermatitis, in a variety of forms.

The use of barrier creams, although traditional in many occupations, should not be considered as personal protective equipment. It provides negligible protection and is unlikely to be effective in preventing contact dermatitis. The benefit of barrier creams is in preventing dirt from becoming so ingrained that it is difficult to remove.

A properly implemented skin-care hygiene programme, including barrier creams, emollient and skin-conditioning creams can help protect and replace the natural skin oil which is otherwise removed by degreasants and solvents. Before undertaking this, advice should be sought from independent skin-care specialists or a dermatologist.

## **Safe and Correct Handling, Use, Maintenance and Storage of Different Types of PPE**

### **Safe and correct handling and use of PPE**

PPE should fit properly, snug but not tight or loose, and it should not impede movement or communication. Select the right PPE for the task. Do not wear PPE that could potentially cause injury, such as loose-fitting gloves that could be caught in moving parts of equipment or

machinery. For loose fitting gloves, tape or fold a cuff on the gloves to prevent chemicals from running down the users' arm.

Do not wear PPE outside of laboratory or shop areas to prevent spreading contamination to other areas

Employees must be trained in how to don and doff PPE and the limitations of the PPE for the specific procedure. Workers need to handle PPE safely when removing it from the body to avoid contaminating themselves and surfaces nearby. Disposable gloves, sleeves, shoe covers and Tyvek clothing and potentially contaminated PPE such as aprons, lab coats and other items need to be removed so that any contamination is not exposed. Disposable items should be peeled off turning them inside out as they are removed. Reusable gloves, aprons and other potentially contaminated items should be rinsed off before removing them, and then peeled off or folded so that the contaminated surface is inside.

### **Inspection, maintenance and storage**

The PPE must be inspected for defects every time it is put on. Look for symmetry; does each side look like a mirror image of the other or is one side distorted? Are there any broken, bent, frayed or torn pieces? Are the lenses scratched so they are hard to see through? Is the elastic still springy or is it stretched out? In addition to visual inspection as above, insulating gloves, sleeves and blankets for electrical workers must be electrically tested.

All must be tested prior to initial use, and then every 6 months thereafter for gloves, and every 12 months for sleeves and blankets. PPE should be clean. If dirty, clean it with soap and warm water. Do not use solvents or abrasives to clean it. Store it out of sunlight in an area where it will be protected and kept clean. Replace reusable PPE every 2-5 years, earlier if recommended by the manufacturer or if there is a major impact. Replace any defective parts with parts made by the same manufacturer for that equipment. Do not make makeshift repairs. If it cannot be repaired properly, replace it. Do not use paint or glue on PPE. Use decals or stickers to mark it.

### **Safety and environmental regulations**

For environmental health exposures, the use of standard precautions refers to general contact control practices that prevent contamination of the skin, eyes, mucous membranes, and clothing. These precautions should be observed when contact with potentially hazardous materials, body fluids, fecal material, and other environmental contaminants is a possibility. The following standard precautions should be used during environmental investigations:

#### **Avoid Contact**

When possible, the EH practitioner should try to avoid contact with a potential contaminant. This may require observance from a distance, or referral of the situation to a trained response professional.

### **Wash Hands**

- i. Wash hands with soap and water and dry with disposable towels after any potential contamination may have occurred.
- ii. Hand washing must also be done before putting on (donning) PPE and immediately after removing (doffing) PPE.
- iii. Hand washing should be followed with the application of hand sanitizer, if possible.

### **Occupational risks e.g., falling from heights, bites from insects, cuts**

Occupational risk deals with the probability of injury or illness occurring as a result of hazards within the workplace.

#### **Falling from heights**

The **hazards** and factors affecting the **risk** from working at **height** include vertical distance of a fall, fragile roofs, roof lights, voids, sloping roofs, deteriorating materials, unprotected edges, unstable or poorly maintained access equipment and adverse weather conditions.

#### **Bites from insects**

**Insect bites** are puncture wounds or lacerations made by **insects**. An **insect** may **bite** in self-defense or when looking to feed. **Insects** typically inject formic acid. This can lead to blisters, inflammation, redness, swelling, pain, itching, and irritation.

#### **Cut injuries**

A **cut** is a break or opening in the skin. It is also called a laceration. A **cut** may be deep, smooth, or jagged. It may be near the surface of the skin, or deeper. A deep **cut** can affect tendons, muscles, ligaments, nerves, blood vessels, or bone.

#### **Types of hazards**

A **hazard** is any source of potential damage, harm or adverse health effects on something or someone. Basically, a **hazard** is the potential for harm or an adverse effect (for example, to people as health effects, to organizations as property or equipment losses, or to the environment)



## **Electric shock**

An electric shock happens when an electric current pass through your body. This can burn both internal and external tissue and cause organ damage.

A range of things can that cause an electric shock, including:

- i. Lightning
- ii. Electric machinery
- iii. Electric weapons, such as tasers
- iv. Household appliances
- v. Electrical outlets
- vi. Power lines

While shocks from household appliances are usually less severe, they can quickly become more serious if a child chews on an electric cord our puts their mouth on an outlet.

Aside from the source of the shock, several other factors affect how serious an electric shock is, including:

- i. Voltage
- ii. Length of time in contact with the source
- iii. Overall health
- iv. Electricity's path through your body
- v. Type of current (an alternating current is often more harmful than a direct current because it causes muscle spasms that make it harder to drop the source of electricity)

If you or someone else has been shocked, you may not need emergency treatment, but you should still see a doctor as soon as possible. Internal damage from electric shocks is often hard to detect without a thorough medical exam.

## **Learning Activities**

You are a lead technician in one of the big textile industries in Kenya. While working in the production line, the production manager announces that there is a fire outbreak in the line. While the workers are running out for, the production manager falls down and he gets burnt. Perform a first to him before he is taken to hospital for further medication

## **Self-Assessment**

1. How are accident reports written?
2. OSHA encourages employers to investigate all instances where someone was hurt or incidents where the worker would be injured if circumstances had been slightly different. Choose Hazards controls and eliminating any future accidents.
3. What are common hazards at a construction site?

4. What are different types of workplace safety?
5. How can I improve my workplace safety?

### **Tools, Equipment, Supplies and Materials**

- i. Multimeter/AVO meter
- ii. Wattmeter
- iii. Insulation resistance tester
- iv. Loop impedance tester
- v. Earth resistance tester
- vi. Clamp meter
- vii. Power quality analyser
- viii. Infrared camera
- ix. Phase sequence meter
- x. Frequency meter
- xi. Synchroscope
- xii. Tachometer
- xiii. Tacho generator
- xiv. Laser meter
- xv. Lux meter

### **References**

- i. Chester Razer, OSHA Field Guide: Understand Workplace Safety & Save Money, 2019,
- ii. Trevor Linsley, Basic Electrical Installation Work, fourth edition, Elsevier Ltd.

### **Answers to self-assessment test**

1. When an accident occurs in the workplace it is important to do everything possible to get the treatment you need right away. Even if you don't believe the injury is too serious or life threatening, it is typically best to go to the doctor to get it checked out. Once you are certain that you are physically ok, you will need to write up an accident report. This report is submitted to the safety manager, HR, and potentially other groups.
2. It can be helpful for choosing hazards controls and eliminating any future accidents.

**Create the Report ASAP:** One of the most important things to do is write up the report as soon as possible after the incident occurs. This will help to ensure you remember the facts as clearly as possible. In addition, anyone else who was involved with the accident, and those who witnessed it, should also write their report right away.

**Document Evidence:** While this is certainly not a criminal investigation, it can be helpful to treat it like one. Documenting evidence like malfunctioning machinery, objects in the wrong place, and anything else that may have contributed to the accident is very important. Take pictures of anything related to the incident. Writing down the names of witnesses, the details of the surrounding environment, and other details will help make it easier to recreate the event if necessary.

**Cooperate with Safety Professionals:** Once you turn your accident report into your safety manager, they will almost certainly conduct a review on the incident. Some people are hesitant to work with them because they may fear that they are going to get in trouble. A good safety manager will want to work with everyone involved in the incident to discover the root cause so that actions can be taken to prevent further problems in the future.

3. Below are some of the most common dangers found in a construction site?

**Confined spaces:** Construction workers often find themselves working in confined spaces. Those working in spaces like manholes, tanks, and crawl spaces can face serious hazards including toxic and harmful substances, electrocutions, explosions, and asphyxiation.

**Falls:** Did you know falls are the leading cause of injury in the construction industry? Construction workers work from heights regularly and employers will need to provide training and proper fall protection in areas like walkways, hoist areas, holes, etc.

**Struck-by hazard:** A number of construction site accidents are the result of a struck-by hazard and there are four categories of struck-by hazards: falling objects, flying objects, swinging or slipping objects, and ground level objects. Every situation is unique, but there are specific safeguards you can put in place to address each hazard.

**Hazardous energy:** Dangerous equipment is often found on a construction site and will need maintenance or service at some point. Construction sites will need to practice a lockout/tag out program to ensure machinery is safely de-energized and re-energized when it is being worked on.

**Chemicals:** Like many other industrial workplaces, construction sites usually deal with a variety of toxic chemicals. Hazard communication is a standard notorious for being violated; the correct labeling of these chemicals and adherence to the GHS standard will not only keep workers safe but keep your organization in compliance.

4. OSHA has identified five different types of hazards that affect most workplaces. These are hazards that can be found in nearly every type of facility and should be addressed to keep workers from injury or health problems.

**Safety hazards:** Safety hazards are the most common type of hazard and they are present in virtually every workplace at one time or another. These hazards are unsafe conditions in a facility that can cause injury, illness, or even death. Think of hazards like spills, working from heights, unguarded machinery, wiring issues, confined spaces, forklifts, and more.

**Biological hazards:** Biological hazards affect those who work with animals, people, or infectious plant materials. People who are working at daycare centers, colleges, hospitals, nursing homes, etc. can be exposed to blood or other body fluids, fungi and mold, bacteria, viruses, and more.

**Physical hazards:** Physical factors encompass environmental factors that can cause harm to workers even when they're not directly touched. Radiation, high sunlight exposure, working in extreme temperatures, and constant loud noises are all examples of physical hazards.

**Ergonomic hazards:** These hazards can be the hardest to identify, but they can easily cause strain (and eventually injury) to the body. Workers can face ergonomic hazards if their workstations or chairs are improperly adjusted, if they're frequently lifting, if they're making repetitive and awkward movements and other situations where the body and muscles are overworked.

**Chemical hazards:** Any chemicals in the workplace can put workers at risk. Some chemicals are far more dangerous than others, but even common chemicals can cause skin irritation, illness, or respiration problems.

5. Workplace safety should be a continuous effort for any company. You will most likely never achieve perfect safety, so there will always be areas for improvement. Here are some ways you can start improving the safety of your facility:

**Organize:** Often times a messy or cluttered facility can lead to injury. A great first step in improving your safety strategy is to organize workbenches and cells. Arranging spaces in a

logical manner, organizing tools and materials, and cleaning will make it much easier for people to do their job without worrying about slipping or tripping.

**Develop a committee:** Workplace safety is seen as a priority when workers are brought together to form a safety committee. The safety committee is a permanent committee dedicated to identifying potential safety risks and implementing a solution. Senior management should support changes or improvements recommended by the committee.

**Perform a JSA:** In order to fully understand the state of your facility's safety it will be important to conduct a Job Safety Analysis. It proves use to identify safety hazards in specific jobs and use accepted best practices to make improvements; the more specific the better!

**Go visual:** Visual cues are one of the most effective ways to remind workers of safety practices and promote a culture of safety. The best visual communication strategies include a combination of equipment labels, wall signs, floor signs, floor markings, chemical labels, and more.

**Take a Gemba walk:** Sometimes managers and supervisors don't spend much time on the production line or the facility floor and can often overlook safety hazards. Taking a Gemba walk in the workplace and speaking with the frontline workers can show you if jobs are being performed safely, if there are any glaring issues, and how people feel about current safety procedures.

### 3.1. Select wiring devices

#### Introduction to the learning outcome

Selecting and applying wiring devices. Receptacles, switches, plates, and cord connector bodies are available in a wide range of sizes, ratings, and styles with specific features and characteristics to meet most design/application requirements. Grades of wiring devices  
Manufacturer's catalogs use a variety of terms to indicate the quality or grade of wiring devices offered. For example, the term "economy,"

#### Performance Standard

1. Interpretation of the drawings.
2. Identification of correct type and quantity of wiring devices and consumable items
3. Selection of tools and equipment
4. Identification and selection of correct PPE.

#### Information Sheet

#### Reading and interpreting drawings to determine job requirements.

Electrical drawings are a formal and precise way of communicating information about the layout, the dimensions, features and precision of Electrical installations. Drawing is the universal language of engineering. To understand how to “read and interpret” a drawing it is necessary to be familiar with the standard conventions, rules, and symbols used on the various types of electrical drawings.

The purpose of this is to prepare electrical personnel with the ability to read and understand the electrical diagrams, various standards and practices used for reading and Interpreting electrical drawings and schematics. Participants will be introduced to electrical symbols, one-line and three-line electrical schematics and their content, including basic layout and legends.

The learning outcome will help the attendees understand the symbols and the language used in electrical drawings in line with the international standards and practices, giving a detailed insight into the various types of electrical drawings used in the industry, their purpose and applications.

**Symbols** are a shorthand way of showing the locations, types, and sizes or ratings of **electrical** wiring and equipment, and the interrelationships between these items. It should be emphasized that **drawings** need to be supplemented with specifications in order to establish the details of the **electrical** systems.

easytvvet.com

# TYPICAL ELECTRICAL DRAWING SYMBOLS AND CONVENTIONS

## ELECTRICAL SYMBOLS

CONTACTS, SWITCHES, CONTACTORS AND RELAYS			
SYMBOL	DESCRIPTION		
	Relay contact - Shown with relay in de-energized or in reset position. (Show relay coil designation near contact.)		Pushbutton - Momentary or spring return. Single Circuit (make)
	Timing Relay Contact - TDC indicates contact closes at end of timing period. TDO contact opens at end of timing period.		Pushbutton - Momentary or spring return. Two Circuit
	Coil - Relay, contactors, circuit breaker, solenoid etc. (Show device designation, XI)		Pushbutton - Maintained, two circuit
	Coil - Timing Relay - TDDO indicates timing period starts when coil is energized. TDDO indicates timing period starts when coil is de-energized.		Pushbutton - Maintained, single circuit
	Latching Relay or Mechanically-Held Contactor O=operate; R=reset; TC=trip coil; CC=closing coil. (Coils may be separated on diagram)		Selector Switch - Two position, maintained (designate position shown; i.e. A=Auto; B=Hand)
	Knife Switch, general. (If shown closed, terminals must be added.)		Selector Switch - Three position, SR indicates spring return from position so labeled. ("TRIP-(NORMAL)-CLOSE" position shown)
	Switch - General, single pole, single throw.		Limit Switch - Normally open - Not applicable for Motor Operated Valves and Solenoid Valves.
	Switch - One pole of multi-pole switch shown. Other poles shown elsewhere.		Limit Switch - Normally closed - Not applicable for Motor Operated Valves and Solenoid Valves.

Table 6: Installation drawing symbols

### Identification of wiring devices

Wiring accessories are used for connecting appliances

### Switch

A switch is used to make or break an electrical circuit.

It is used to switch 'on' or 'off' the supply of electricity to an appliance.

There are various switches such as:

- Surface switch
- Flush switch
- Ceiling switch
- Pull switch
- Push button switch
- Bed switch



Figure 92: Switches

**Surface switch:**

It is mounted on wooden boards fixed on the surface of a wall. It is of three types

- i. One-way switch
- ii. Two-way switch
- iii. Intermediate switch

**One-way switch:** It is used to control single circuits and lamp

**Two-way switch:** It is used to divert the flow of current to either of two directions. The two-way switch can also be used to control one lamp from two different places as in the case of staircase wiring

**Intermediate switch:** It is used to control a lamp from more than two locations.

**Flush switch:**

It used for decorative purpose.

**Bed switch:** As the name indicates, it is used to switch ‘on’ the light from any place, other than switch board or from near the bed. This switch is connected through a flexible wire





one-way switch

two-way switch

easyvet.com

*Intermediate switch*



*Flush Switch*



*Bed switch*

## Holders

A holder is of two types.

- i. Pendant holder

ii. Batten holder



Fig 3.7: Pendant holder



Fig 3.8: Batten holder

**Ceiling rose**

It is used to provide a tapping to the pendant lamp–holder through the flexible wire or a connection to a fluorescent tube.



Ceiling rose

**Socket outlet/plug**

The socket outlet has an insulated base with the molded or socket base having three terminal sleeves.



socket outlet

### Main switch

To control the electrical circuit a main switch is used. Through the main switch, the power in a building is controlled completely.



Main switch

### PVC casing-capping wiring

PVC capping is done in order to cover the wires. It includes casing also. This casing-capping wiring is also known as open wiring, as it is done outside the wall. Materials required for PVC casing-capping wiring include:

- i. Wire
- ii. Casing enclosures made up of plastic
- iii. Capping made up of plastic
- iv. T. Joints VIR (Vulcanized Indian Rubber) or PVC (Polyvinyl chloride) insulated wire
- v. Junction box
- vi. Elbow
- vii. Casing and capping joints

Wooden casing-capping wiring is old fashioned. Now PVC or VIR insulated wires are enclosed within the PVC casing enclosure and PVC capping is used to cover the casing.



PVC casing-capping accessories



PVC casing-capping bend

### Advantages of casing-capping wiring

- i. Easy to install
- ii. Strong and durable wiring
- iii. Customization can be done easily
- iv. Safe from smoke, dust, rain and steam, etc.
- v. No risk of shock due to casing and capping,

### **Disadvantages of PVC casing-capping wiring**

- i. Costly
- ii. Not suitable for humid weather
- iii. High risk of fire

### **Miniature Circuit Breaker (MCB)**

A MCB is used in new constructions instead of the older types of fuses. Circuit breakers are small devices used to control and protect the electrical panel and the other devices from overflowing of electrical power.



Figure 93: MCB Distribution Box

### **Uses of MCB**

#### **Home electrical panels**

As with all breakers, the MCB is designed to protect the house from circuit overload. An MCB is much safer than the typical fuse, because it can be reset manually and can handle larger amounts of power. The breaker can manage the flow of energy, distributing the voltage even when many devices run off the same power circuit.

### **Lights**

MCBs are used in the lighting system of the house, because they can deal with the amount of power needed to lightening a house, especially if specific types of lamps, such as fluorescent lights are used. MCBs overcome the need of additional power required when switching on the lights, especially when lights are used extensively in the entire house.

### **Industrial applications**

There are many small-scale industrial buildings where MCBs are used instead of the old fuses. Miniature circuit breakers are largely used in restaurants, bakeries and commercial food stores.

### **Heaters**

When heaters are used at home or in the office, the MCB can be beneficial. It is known in general that heaters can be problematic sometimes, especially with distribution of electrical power. The MCB prevents possible problems, cutting off electricity in the case of overload or fault. In this case, though, you need to choose a miniature circuit breaker of the proper capacity, enabling it to handle the load of power when needed.

### **Conduit Wiring**

Electrical conduits are used to protect and provide the route of electrical wiring in an electrical system. Electrical conduits are made of metal, plastic, or fibre and can be rigid or flexible. Conduits must be installed by electricians as per standard regulations. For workshops and public buildings, conduit wiring is the best and most desirable system of wiring. It provides protection and safety against fire.



Figure 94: Conduiting Wiring



Figure 95: Conduit Wiring Components

### **Types of Conduits**

- i. Class A conduit: Thin layered steel sheet of low gauge
- ii. Class B conduit: Thick steel sheet of high gauge

### **Some of the materials used in Conduit Wiring**

- i. GI (Galvanized Iron) wire
- ii. Elbow
- iii. Coupling
- iv. VIR or PVC insulated cables
- v. Lock nut
- vi. Clip
- vii. Junction Box

### **Advantages of conduit wiring**

- i. Safe
- ii. Better appearance
- iii. No risk of fire
- iv. No risk of damage of cable insulation
- v. Safe from humidity, smoke, steam, etc.
- vi. No risk of shock

vii. Long lasting

### **Disadvantages of conduit wiring**

- i. Expensive
- ii. Installation is not easy
- iii. Not easily customizable for future use
- iv. Hard to detect faults

### **Testing the functionality of the devices and appliances**

Appliances with electrical problems can be a fire hazard or electrical shock risk. Even a refrigerator or dishwasher can be dangerous if not properly tested and maintained.

### **Electrical appliance testing falls into two broad categories:**

**Hot Tests:** Tests made with power applied to the unit

**Cold Tests:** Tests made with the unit unplugged

### **Electrical Appliance Testing Equipment**

What equipment is required for appliance electrical testing?

#### **A non-contact millimeter**

This is the most economical tool, as it fulfills the role of a non-contact voltage meter, continuity meter and more. Non-contact (clamp-style) millimeters use magnetic inductance to measure current flow, so they are safest to use on AC circuits and can measure much higher amperage values than lead-only-style millimeters.

#### **A professional**

The truth is, electrical appliance testing is dangerous. We recommend having a professional check it out. If there's a bigger electrical problem tied to your appliance issue, call a trusted electrician.

### **Appliance Electrical Testing Steps**

During appliance electrical testing processes, professionals typically measure three different electrical parameters: continuity, voltage, and amperage.

**Safety first:** Do not touch any electrical components with your skin, do not touch the metal tips of the multicenter leads, and do not touch the multimeter's leads together.

## Continuity

- ❖ Unplug the appliance first, and disconnect it from any water or gas lines.
- ❖ Turn your multimeter to the "ohms" function ( $\Omega$ ).
- ❖ Now test for electrical continuity of the switches, thermostats, and other contacts that are supposed to be closed.
- ❖ To do this, touch one end of the multimeter's lead to a terminal (the part's contact point) and the other end to the opposite contact point.
- ❖ Closed contacts should read 2 ohms or less if they have proper continuity. If the ohms read higher than 2, the electrical control you are testing should probably be replaced.
- ❖ Some parts (beyond those mentioned above) should have different resistance. Consult the manufacturer's manual to make sure you're looking for the right ohms reading.

## Voltage

- ❖ These steps can be taken after voltage in the outlet is already safely confirmed.
- ❖ First, make sure the appliance is turned off and plugged in.
- ❖ To see if there's voltage running "downstream" of the outlet into the appliance, turn your multimeter to the AC volts setting ( $\checkmark$ ).
- ❖ With the appliance turned off, touch the multimeter's leads to the circuit. Read the voltage.
- ❖ The target voltage depends on the type of appliance you have and the components you're testing.
- ❖ When testing voltages to electric dryer heating elements and electric range or stove elements, look for 240 volts AC.
- ❖ When testing for control voltages to solenoids, timers, and other components on your 120-volt appliances, look for 120 volts AC.
- ❖ If the voltage reads lower than it should, you likely have one of these problems:
- ❖ A circuit issue—usually an open switch or thermostat or one with poor continuity
- ❖ A bad wire connection—look for burnt or discolored wires.

## Amperage

- ❖ Testing for amperage, or current, is another way of testing for continuity. The main difference is that amperage tests are made with the appliance plugged in.
- ❖ Set the multimeter to the "amps" range (A), not the "milliamperes" range.
- ❖ Turn off the appliance, and connect the multimeter to the circuit to be tested.
- ❖ Turn the appliance back on, and get the multimeter reading.
- ❖ Consult your appliance manual to see if the amps detected match the operating load of your unit.



- ❖ If the amp reading is lower than it should be, there may be a failed component causing the resistance to be higher. If the amperage is much too high, a failed part may be causing a short and lowering the resistance.

### **Learning Activities**

Adjust the electrical accessories like, switches, holders, sockets, etc. on the given board or round block. And then mark their positions by a pencil. Remove the covers of the accessories and loosen the screws of terminals. Make a powder of chalk and pour it in the holes of the terminal. Mark the point on them by the poker. Now make the holes on the round block or board by the drilling machine where the points have been marked. Insert the wires in the terminal, after removing the insulation. Then fix all the accessories on the board or round block by wooden screws after making holes on them by the poker. Then fix all covers on the accessories.

### **Tools and materials required**

- i. Hand drilling machine with a drift bit of 5 centimeter
- ii. Poker
- iii. Screwdriver
- iv. Connector screwdriver 8 cms
- v. Combination plier 15 cm
- vi. Try square
- vii. Firmer chisel 20 mm
- viii. Electrician knife 10 cm

### **Material**

- i. Wooden round block/ PVC Round Block
- ii. Wooden board/ Sun mica Board
- iii. Single pole one-way switch 5 A, 250V
- iv. PVC wire
- v. Pencil
- vi. Chalk

All the fittings (switch, holder) should be fitted well. No naked portion of the conductor should remain visible. The screws in the accessories fitted should be tight. The tools should be used carefully.

### **Self-Assessment**

1. How do I know if my electrical wiring connection is good or bad?
2. What is the difference between neutral and earth lines?
3. How do you differentiate MCB from a fuse?

4. How do you wire one lamp controlled by two switches?
5. What is an isolator?

### **Tools, Equipment, Supplies and Materials**

- i. Multimeter/AVO meter
- ii. Wattmeter
- iii. Insulation resistance tester
- iv. Loop impedance tester
- v. Earth resistance tester
- vi. Clamp meter
- vii. Power quality analyser
- viii. Infrared camera
- ix. Phase sequence meter
- x. Frequency meter
- xi. Synchroscope
- xii. Tachometer
- xiii. Tacho generator
- xiv. Laser meter
- xv. Lux meter

### **References**

- i. Black & Decker, the Complete Guide to Wiring, 7th edition, Cool springs press.
- ii. <https://ncert.nic.in/vocational/pdf/kvcj103.pdf>

### **Answers to self-assessment test**

- i) Some electrical connections are good others not so much! Product manufacturers might give you a choice of connection points which include switches and outlets. You may be able to ascertain which will be the wisest choice by researching and using common sense. Whatever you do, beware of loose connections that can cause devices to heat up and result in an electrical fire. Create a safe and secure connection that will last a long time.
- ii) Neutral – Return line or return path of current, connected to the start point of the transformer usually connected to ground.  
Earth – Connected to earth or soil through an earth rod that offers a low resistance current path for electric discharges. It carries current during a fault condition and not a current-carrying path under normal condition.
- iii) Both devices have the same function they are used to protect the electrical system from over current and overload, but they are different in both construction and operation.

MCB's are more preferable because it offers better sensitivity, accuracy, precision, etc. The main advantages are MCBs can be operated safely as just like a switch. Whereas a fuse needs to very carefully plugin to and out from live conductors and the fuse wires need to be replaced after every burnout.

- iv) By wiring, the load using multiway switching or staircase wiring one lamp can be controlled from two switches placed at different locations like the top and bottom of a staircase, indoor and outdoor of the home, etc.

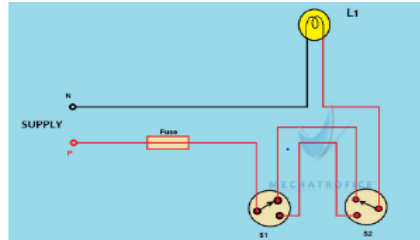

Figure 96: One Lamp Controlled by two switches

- v) An isolator is a mechanical switching device used for isolating a circuit or equipment from the power source.

### 3.2. Install wiring devices, lighting fixtures and basic appliances

#### Introduction to the learning outcome

Electrical wiring needs expertise attention to every building project. It directly related to the safety of human beings and utilities equipment people handle.

#### Performance Standard

1. Power points identification
2. Installation of light fixtures
3. Identification and selection of tools, equipment and materials
4. Termination and fitting of wiring devices, lighting fixtures and basic appliances
5. Earthing of the wiring devices, lighting fixtures and basic appliances
6. Labeling of final circuits on the distribution board
7. Maintenance and storage of tools and equipment

#### Information Sheet

### **Use of safety harness and PPE**

The best way to keep people safe from electrical hazards in the workplace is by implementing policies and procedures that reduce or eliminate various risks. Unfortunately, it is impossible to take steps that can be 100% effective, and if there is even one incident it can be deadly. With this in mind, it is important that anyone working with or around dangerous electrical equipment use personal protection equipment to keep them safe in the event of an accident. The following are among the most frequently used types of PPE, and how they can keep your workplace safer.

**Insulated Gloves** – Insulated gloves will prevent electricity from traveling into your hands should there be an exposed wire, short circuit, or other issue.

**Insulated Matting** – Insulated matting will put a protective layer between the employee and the floor. This is helpful when working at switchboards, transformers, and other high-voltage areas. It can help prevent electricity from traveling up from the floor into the person's body, as well as eliminating a path for electricity to travel through the body and out to the floor.

**Insulated Ladders** – Insulated ladders won't transmit electricity into the person who is using it. If a normal metal ladder accidentally touches a live electrical wire, it can be devastating. With the insulated ladder, this isn't an electrical concern.

**Rescue Rods** – In the event that someone is being electrocuted, people will be tempted to rush in to save them. Unfortunately, this will only lead to them becoming electrocuted as well. Having a rescue rod present will allow those in the areas to pull the victim to safety, or push the source of the electricity away.

**Voltage Detectors** – Even after a power source has been removed, there can still be electricity in a system because of capacitors. A voltage detector will show the level of electricity in a given system at the current time, so employees won't mistakenly begin working on a system until all power has been eliminated.

### **Identification of power points**

A power circuit is defined as any circuit used to carry electricity that operates a load. This may seem like a simplistic definition but it is important to distinguish power circuits from control circuits since they serve different purposes.

All power connection points need to be well marked for easy access.

### **Types of lighting fixtures**

A **light fixture, light fitting, or luminaire** is an electrical device that contains an electrical lamp that provides illumination all light fixtures has a fixture body and one or more

lamps. The lamps may be in sockets for easy replacement—or, in the case of some LED fixtures, hard-wired in place.

Fixtures may also have a switch to control the light, either attached to the lamp body or attached to the power cable. Permanent light fixtures, such as dining room chandeliers, may have no switch on the fixture itself, but rely on a wall switch.

Fixtures require an electrical connection to a power source, typically AC mains power, but some run on battery power for camping or emergency lights. Permanent lighting fixtures are directly wired. Movable lamps have a plug and cord that plugs into a wall socket.

### **Different types of lighting fixtures**

#### **Track**

This type of modern lighting is mounted or suspended from the ceiling. Track lighting is essentially a linear housing that has multiple heads, which can be positioned anywhere along the track. The direction of the heads can be adjusted to provide lighting to specific areas in the room. Many homeowners prefer track lighting for accent lighting and task lighting.



Figure 97: Track Lighting

#### **Recessed and Under-Cabinet**

Recessed lighting fixtures are installed above the ceiling so that the opening can be flush with the ceiling. Recessed lighting requires six inches or more of clearance above the ceiling. Insulation of the lighting fixture is essential, as it ensures that condensation does not drip into the fixture. Recessed lighting projects a narrow band of light in one direction, making it ideal for accent, ambient, and task lighting. Under cabinet lighting is a type of recessed lighting that is mounted under kitchen cabinets. It is very popular for task lighting in the kitchen.

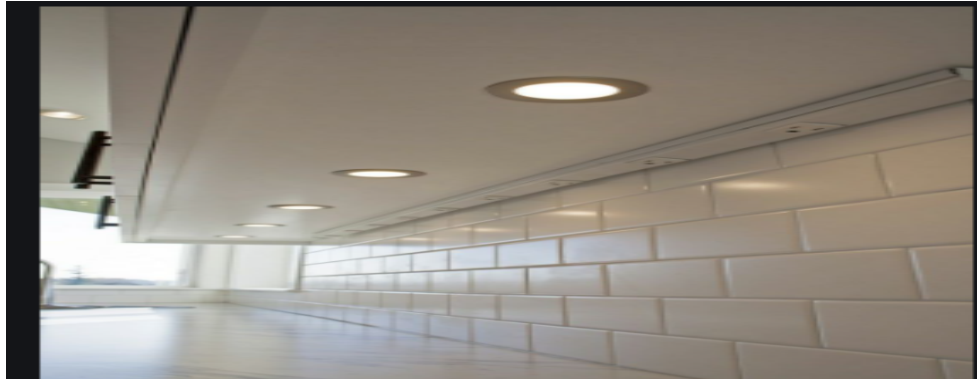

Figure 98: Recessed and Under-Cabinet Lighting

### **Pendants**

Pendant light is suspended from the ceiling and broadcasts light downward, usually over a kitchen island, countertop, or table. A pendant enhances the decor of a room and can make for very attractive task and ambient lighting.

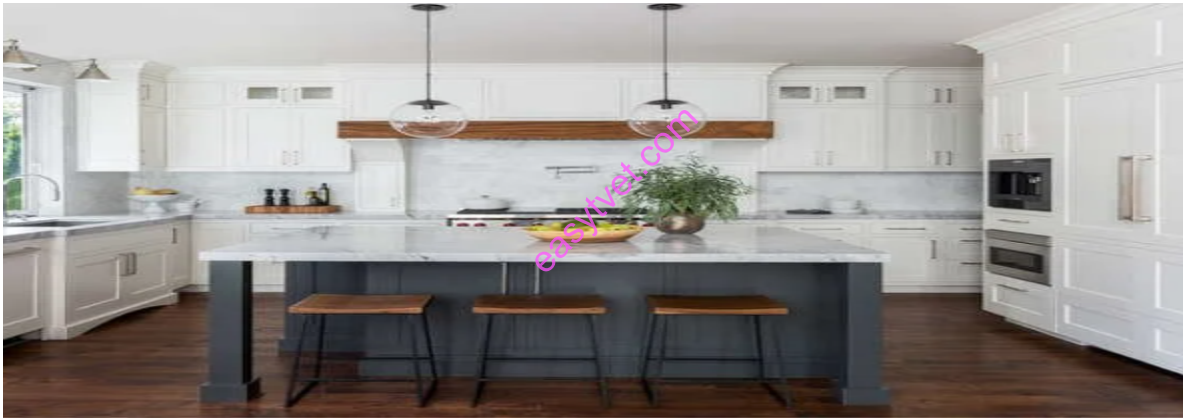

Figure 99: Pendants lighting

### **Chandeliers**

Chandeliers are suspended from the ceiling. They direct their light upward, oftentimes over a table or an entryway. Chandeliers elevate the style of any room and provide attractive ambient lighting.



Figure 100: Chandaria Lighting

### Wall Sconces

Sconces are typically surface-mounted to the wall. They direct light downwards or upwards. Many homeowners buy covers or shades for their wall sconces to add design appeal to a room. Wall scones are especially great for task lighting and ambient lighting.



Figure 101: Wall Sconces lighting

### Identification of lighting fixtures



Antique lighting fixtures are a valuable and inspirational decorative accent in a real estate investment. The historical significance and unique styling associated with antique lighting fixtures make them a luxurious element in a home design. If you have antique lighting fixtures and want to identify them by age, period and genre, there are several ways to evaluate and assess their historical relevance. It's important to research carefully to ensure that a piece is authentic rather than a modern reproduction.

### **Examine the Fixture for Markings**

Study the light fixture for manufacturer impressions, initials and hallmarks. Examine the metal framework supporting the fixture, the base of the light and the arms connecting to the globes. Most markings are company names or signatures that were incorporated into the original casting. According to Vintage Lights, many of the numbers on antique lighting fixtures represent casting marks that showed the installer how to connect the pieces. As a result, some antique fixtures have multiple numbers, primarily used for internal use by the manufacturer. These numbers weren't usually recorded as serial numbers and aren't necessarily useful for identifying the fixture; however, they do help distinguish originals from reproductions.

### **Study the Design Elements**

Research antique lighting styles and visit antique stores to compare and discuss historical influences associated with your lighting fixture. For example, early antique Fenton light fixtures exemplified Gone with the Wind designs and incorporated rounded vertical globes and brass hardware into their construction. Antique Tiffany lamps used colorful stained glass to add color and artistic design to salons and living rooms. Test to see if the glass in a Tiffany lamp is lead-based, likely signifying that it's an antique fixture.

### **Date the House or Location**

Verify the age of your property, or the original location of the light fixture, to authenticate and identify it. If the light fixture was an original that came with your real estate investment, research the history of the house and its previous owners. If a previous owner was a world traveler, there is a strong possibility that the piece could be from a foreign country. Establish the age of your home to get a reliable guesstimate on the age of the fixture. If your home was built post-1950s, the light fixture is probably not antique and is likely a reproduction. Most homeowners took valuable antique possessions with them when they relocated.

### **Compare Fixture to Other Specimens**

Examine antique light fixtures in books, on the Internet and in local museums. Compare your light fixture to others of the same variety. For example, if your fixture has Victorian appeal, compare it to other fixtures from the late 1800s and early 1900s. Take photographs of your light fixture and show it to museum owners and antique dealers to get their professional analysis and



viewpoint. Identification of antique light fixtures isn't an exact science, so comparisons with other similar specimens are often the key to identification.

### **Identification of tools and equipment**

Basic electrical tools, equipment, and their uses include:

#### **Pliers**

Pliers are available in different types, shape, and sizes. They are also available in both insulated and uninsulated handles. An insulated handle should be used when working on or near hot wires. It is also used for cutting big and small wires.



Pliers

#### **Screw Drivers**

A screwdriver comes in various sizes and with several tip shapes. Screwdrivers used by electricians should have insulated handles. Using a screwdriver for a particular job, the width of the screwdriver tip should match the width of the screw slot.



Screw drivers

#### **Drilling Equipment**

Drilling equipment is needed to make holes in building structure passages of conduits and wires.



Driller

### **Sawing and Cutting**

Tools Saws commonly used by electricians include the crosscut, keyhole, and hacksaw.



Hark saw

### **Soldering Equipment**

In doing electric wiring splices and taps (connections made to wire) should be soldered, unless you use solderless connectors. Typical equipment available for soldering are shown below.



Soldering equipment

### **Hammers**

Hammers are used with chisels and for nailing and fitting. Below are examples of carpenter's claw hammer, lineman's hammer, and machinist's ball-peen hammer



Hammers

### Measuring Tools

To measure wire length and other items, the electrician finds considerable use for measuring tools such as the extension or zigzag rule, push-pull rule and a steel tape as shown below.



Measuring tools

### Assembling of tools and equipment

Here's how to put together a comprehensive tool box full of hand and power tools that will allow you to tackle almost any home repair.

[https://www.youtube.com/watch?v=4T3UvYN-bbw&feature=emb\\_logo](https://www.youtube.com/watch?v=4T3UvYN-bbw&feature=emb_logo)

### Termination and fitting of wiring devices, lighting fixtures and basic appliances

For centuries, copper wire has been used as an electrical conductor. But wire requires termination. Simple screw clamps were originally used to terminate wire. Although screw clamps are still used today, there are now numerous means to terminate wires.

### Soldering

Soldering offers flexibility, durability and corrosion-resistance. Connections can be made and removed easily, which simplifies prototyping and fieldwork.

### Insulation Displacement Connections

Insulation displacement connectors (IDC) are probably the fastest way to terminate wires. IDCs were first used in the telecom industry on small, stranded wire. The process can quickly and efficiently terminate the hundreds of wires in large patch panels.

### **Crimping**

Crimping is the most commonly used method of wire termination, and is most efficient for high-volume wire termination. The terminations are fast, clean and mechanically strong.

### **Ultrasonic Welding**

Ultrasonic welding is used in various bonding applications, such as joining such dissimilar metals as copper, aluminum, nickel and brass.

### **Earthing of the wiring devices, lighting fixtures and basic appliance**

The process of transferring the immediate discharge of the electrical energy directly to the earth by the help of the low resistance wire is known as the electrical earthing. The electrical earthing is done by connecting the non-current carrying part of the equipment or neutral of supply system to the ground.

Mostly, the galvanized iron is used for the earthing. The earthing provides the simple path to the leakage current. The short-circuit current of the equipment passes to the earth which has zero potential. Thus, protects the system and equipment from damage.

### **Types of Electrical Earthing**

The electrical equipment mainly consists of two non-current carrying parts. These parts are neutral of the system or frame of the electrical equipment. From the earthing of these two non-currents carrying parts of the electrical system earthing can be classified into two types.

- i. Neutral Earthing
- ii. Equipment earthing.

### **Neutral Earthing**

In neutral earthing, the neutral of the system is directly connected to earth by the help of the GI wire. The neutral earthing is also called the system earthing. Such type of earthing is mostly provided to the system which has star winding. For example, the neutral earthing is provided in the generator, transformer, motor etc.

### **Equipment Earthing**

Such type of earthing is provided to the electrical equipment. The non-current carrying part of the equipment like their metallic frame is connected to the earth by the help of the conducting wire. If any fault occurs in the apparatus, the short-circuit current to pass the earth by the help of wire. Thus, protect the system from damage.

## Importance of Earthing

The earthing is essential because of the following reasons:

- i. The earthing protects the personnel from the short-circuit current.
- ii. The earthing provides the easiest path to the flow of short-circuit current even after the failure of the insulation.
- iii. The earthing protects the apparatus and personnel from the high voltage surges and lightning discharge.

Earthing can be done by electrically connecting the respective parts in the installation to some system of electrical conductors or electrodes placed near the soil or below the ground level. The earthing mat or electrode under the ground level have flat iron riser through which all the non-current-carrying metallic parts of the equipment are connected.

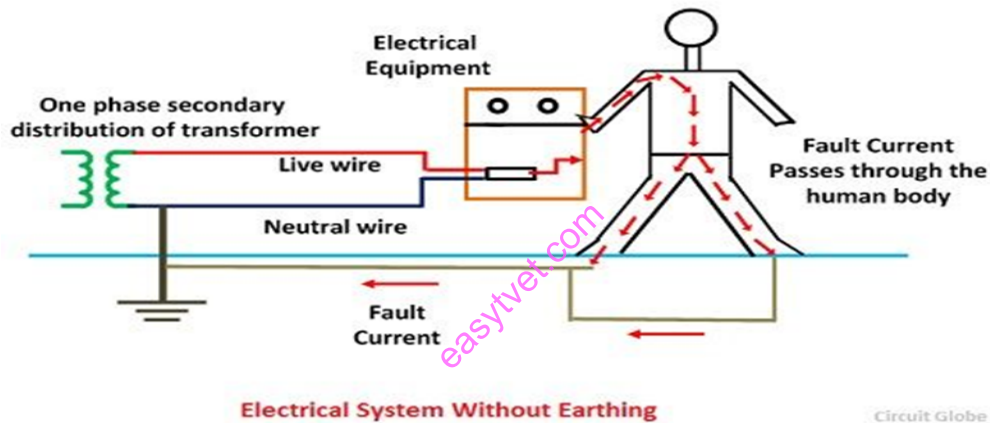

Figure 102: Electrical System Without Earthing

When the fault occurs the fault current from the equipment flows through the earthing system to the earth and thereby protects the equipment from the fault current. At the time of the fault, the earth mat conductors rise to the voltage which is equal to the resistance of the earth mat multiplied by a ground fault.

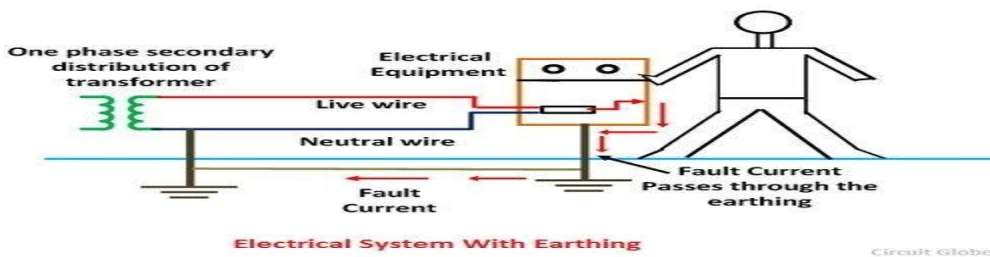

Figure 103: Electrical system with Earthing

The contacting assembly is called earthing. The metallic conductors connecting the parts of the installation with the earthing are called electrical connection. The earthing and the earthing connection together called the earthing system.

### Types of Earthing Systems,

**TNC, TNS, TNCS, TT, IT.**

TN-S (T- EARTH, N –NEUTRAL, S-SEPARATE)

TN-C-S (T-EARTH, N –NEUTRAL, C-COMBINED, S-SEPARATE)

TN-C (T-EARTH, N –NEUTRAL, C-COMBINED,)

IT (ISOLATED EARTH)

**Component parts of earthing system are to include the following:**

- i. Earth electrode (rods, tapes etc.)
- ii. Main earthing terminals or bars.
- iii. Earthing conductors.
- iv. Protective conductors.
- v. Equipotential bonding conductors.
- vi. Electrically independent earth electrodes for special systems (clean earth)

### Methods of Earthing.

There are several methods of earthing like wire or strip earthing, rod earthing, pipe earthing, plate earthing or earthing through water mains. Most commonly used methods of earthing are pipe earthing and plate earthing. These methods are explained below in details.

### Earthing Mat

Earthing mat is made by joining the number of rods through copper conductors. It reduced the overall grounding resistance. Such type of system helps in limiting the ground potential. Earthing mat is mostly used in a placed where the large fault current is to be experienced. While designing an earth mat, the following step is taken into consideration.

In a fault condition, the voltage between the ground and the ground surface should not be dangerous to a person who may touch the noncurrent-carrying conducting surface of the electrical system.

The uninterrupted fault current that may flow into the earthing mat should be large enough to operate the protective relay. The resistance of the ground is low to allow the fault current to flow through it. The resistance of the mat should not be of such a magnitude as to permit the flow of fatal current in the live body.

The design of grounding mat should be such that the step voltage should be less than the permissible value which would depend on the resistivity of the soil and fault required for isolating the faulty plant from the live system.

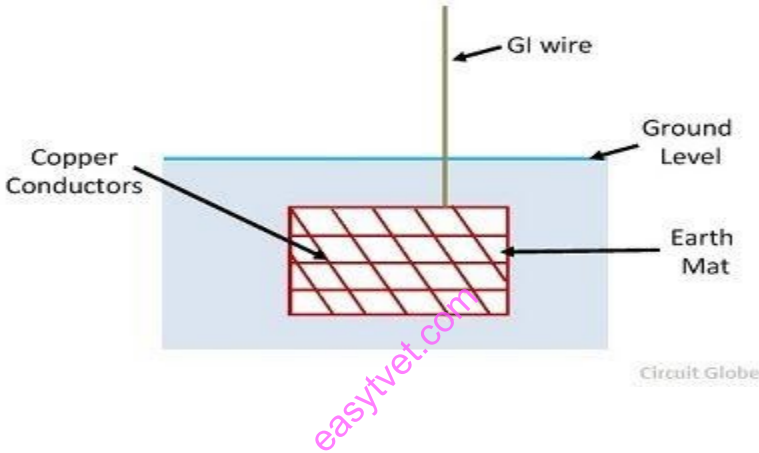
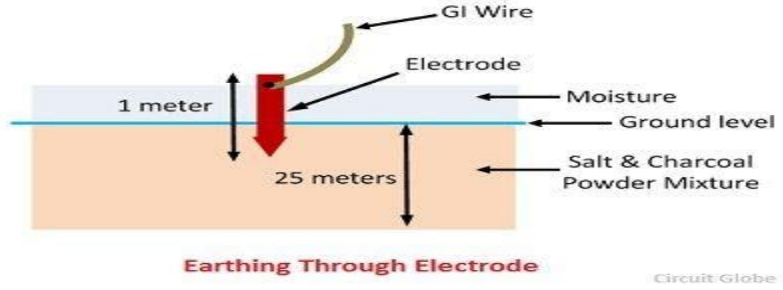

Figure 104: Earth Mat

**Earthing Electrode**

In this type of earthing any wire, rod, pipe, plate or a bundle of conductors, inserted in the ground horizontally or vertically. In distributing systems, the earth electrode may consist of a rod, about 1 meter in length and driven vertically into the ground. In generating substations, grounding mat is used rather than individual rods.



Earthing electrode

**Pipe Earthing**

This is the most common and best system of earthing as compared to other systems suitable for the same earth and moisture conditions. In this method the galvanized steel and perforated pipe of approved length and diameter is placed upright in a permanently wet soil, as shown below. The size of the pipe depends upon the current to be carried and type of soil.

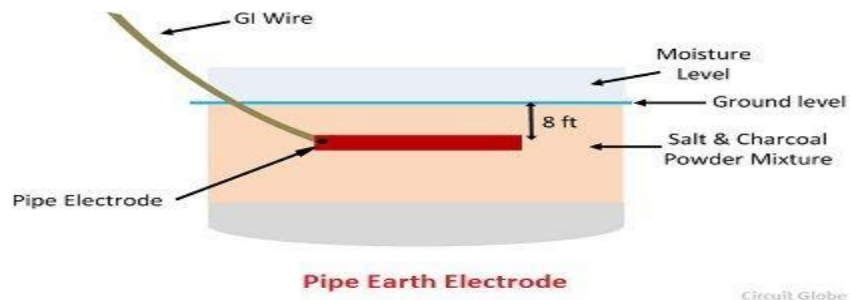

Pipe earth electrode

Normally, the size of the pipe used for earthing is of diameter 40 mm and 2.5 meters in length for ordinary soil or of greater length in case of dry and rocky soil. The depth at which the pipe must be buried depends on the moisture of the ground.

The pipe is placed at 3.75 meters. The bottom of the pipe is surrounded by small pieces of coke or charcoal at a distance of about 15 cm. Alternate layers of coke and salt are used to increase the effective area of the earth and to decrease the earth resistance respectively.

Another pipe of 19 mm diameter and minimum length 1.25 meters is connected at the top of GI pipe through reducing socket.

During summer the moisture in the soil decreases, which causes an increase in earth resistance? So, a cement concrete work is done to keep the water arrangement accessible, and in summer to have an effective earth, 3 or 4 buckets of water are put through the funnel connected to 19 mm diameter pipe, which is further connected to GI pipe.

The earth wire either GI or a strip of GI wire of sufficient cross section to carry faulty current safely is carried in a GI pipe of diameter 12 mm at a depth of about 60cm from the ground.

### Plate Earthing

In Plate Earthing an earthing plate either of copper of dimension 60cm×60cm×3mm or of galvanized iron of dimensions 60 cm× 60 cm×6 mm is buried into the ground with its face vertical at a depth of not less than 3 meters from ground level.



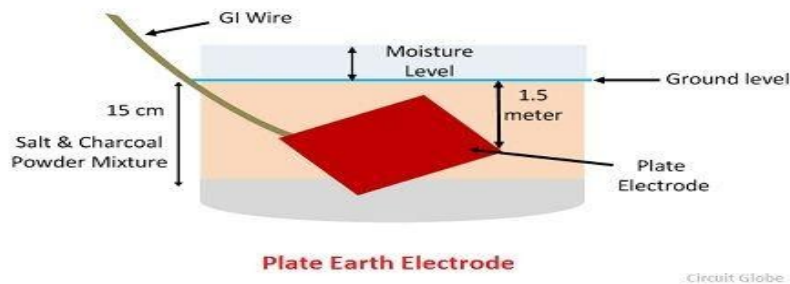
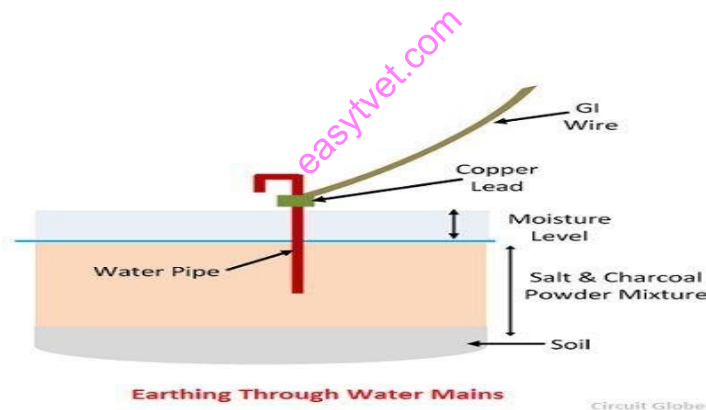

Plate earth electrode

The earth plate is inserted into auxiliary layers of coke and salt for a minimum thickness of 15 cm. The earth wire (GI or copper wire) is tightly bolted to an earth plate with the help of nut or bolt. The copper plate and copper wire are usually not employed for grounding purposes because of their higher cost.

### Earthing Through Water Mains

In this type of earthing the GI or copper wire are connected to the water mains with the help of the steel binding wire which is fixed on copper lead as shown below.



Earthing through water mains

The water pipe is made up of metal, and it is placed below the surface of the ground, i.e. directly connected to earth. The fault current flow through the GI or copper wire is directly get earthed through the water pipe.

**Over-current protection** is protection against excessive currents or current beyond the acceptable current rating of equipment. It generally operates instantly. Short circuit is a type of over-current. Magnetic circuit breakers, fuses and over-current relays are commonly used to provide over-current protection.

[easytvvet.com](http://easytvvet.com)

## Test for an earthing system

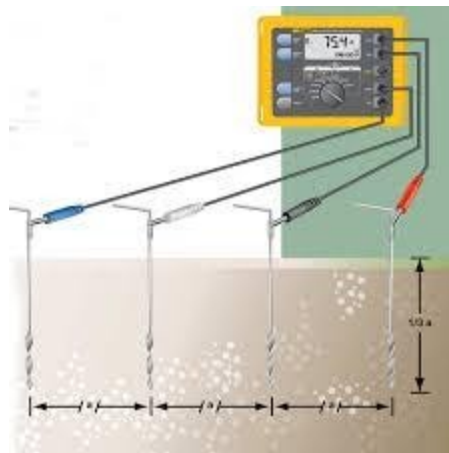

Figure 105: Earth Test System

The fall-of-potential test method is used to measure the ability of an earth ground system or an individual electrode to dissipate energy from a site. ... Then, two earth stakes are placed in the soil in a direct line – away from the earth electrode, for the 3-pole fall of potential test. The earth ground tester works on the principle that in parallel/multi-grounded systems, the net resistance of all ground paths will be extremely low. A good connection is defined as having a resistance of less than 0.1 ohms (or 100 milli-ohms). The Earth Continuity test is sometime referred to as the Earth Bond test or the Earth Resistance test.

### Labeling of final circuits on the distribution board

#### Branch circuit panel board directories

- A. Provide neatly typed schedule under plastic jacket or protective cover for protection from damage or dirt.
  - i. Number each single pole space: Odd-numbered circuits on left side or top, even on right side or bottom.
  - ii. Securely mount on inside face of panel board door.
  - iii. When there is no cover, provide individual nameplates for each over-current and other device.
  - iv. Define briefly, but accurately, nature of connected load (i.e., Lighting Office, Receptacles, Mechanical/Electrical Room, etc.) as approved.
  - v. Provide room locations for all loads and indicate panel name on the schedule.
  - vi. Multipole circuits: Use first pole space number as circuit number.
- B. Confirm room numbers with UC Construction Management before noting on schedules.
  - i. Spare circuit breakers and space positions shall be noted in pencil.

- ii. Panel schedules and as-built circuit numbers shall agree.

**Wire and cable labeling**

**Control wiring**

All control-wire terminations are to be identified by tubular sleeve heat shrink-type markers to agree with wire marking identification on manufacturer's equipment drawings.

**Power conductor wire, cable, and buses**

Buses, feeders, branch circuit conductors, and medium-voltage cables shall be properly phased and identified throughout. Individual conductors shall be color coded as noted below.

<b>Conductor</b>	<b>102/208V and Medium Voltage</b>	<b>277/480V</b>
<b>Phase A</b>	Black	Brown
<b>Phase B</b>	Red	Orange
<b>Phase C</b>	Blue	Yellow
<b>Neutral</b>	White	Gray
<b>Ground</b>	Green	Green
<b>Isolated Ground</b>	Green/Yellow	Green/Yellow

Table 7: Colour codes

Buses and connections shall be identified left to right, top to bottom, or front to rear; shall read A-B-C; and shall be color-coded per the table above.

Feeders for all new construction shall have color-coded phase identification at all junction boxes and wherever feasible, and shall have solid color-coded insulation for phase designation. Where the proper color wire insulation cannot be obtained, black insulation shall be used and the conductors shall be coded with plastic vinyl tape, 3M #190-A, 3/4 inch or equal.

Identify color-coded conductors with appropriately colored plastic vinyl tape (3M #190-A) in the panel when branch circuits are reconnected for balancing panel load.

**"Low voltage" cable and special systems**

See individual functional specification sections.

**Color scheme for labels**

See attached standard drawings for examples

<b>System</b>	<b>Label Color</b>	<b>Lettering Color</b>	<b>Identification</b>
<b>2.4 kV and 4.16 kV emergency</b>	Red	White	
<b>13.8 kV normal</b>	Yellow	Black	
<b>2.4 kV normal</b>	Orange	White	
<b>Normal power and control</b>	White	Black	
<b>Emergency power and control:</b>			
<b>Emergency – life safety</b>	Red	White	"EM - LS"
<b>Emergency – critical</b>	Red	White	"EM - CR"
<b>Emergency – legally required standby</b>	Red	White	"EM - LRS"
<b>Emergency – optional standby</b>	Red	White	"EM – OS"
<b>Fire alarm</b>	Red	White	"FA"
<b>Halon</b>	Dk. Blue	White	"FP"
<b>Security</b>	Green	Black	"SEC"

<b>Intercom, public address, nurse call</b>	Orange	Black	"IC", "PA", or "NC" (as app.)
<b>Clock</b>	Lt. Blue	Black	(Symbol for Clock)
<b>TV</b>	Yellow	Black	"TV"
<b>Communication data</b>	Black	White	"C/D"

Table 8: Colour scheme for labels

### **Conducting final checks for workmanship, conformity with instructions and job requirements**

At the completion of the electrical installation works, the entire installation shall be subject to the test before final placing in service under the full responsibility of the contractor. Unless otherwise specifically called for all tests shall be carried out in conformity with IEE regulations. Contractor shall coordinate with the Client and the Supervising Engineer to get electricity from the local supply authority before starting of testing and commissioning.

**Following tests shall be carried out:** Wiring continuity test, Insulation resistance test, Earth continuity test, Earth resistivity test, Performance test, and any other tests as instructed by the Supervising Engineer.

### **Electrical wiring continuity testing**

All wiring system shall be tested for continuity of circuits, short circuits and earthing after wiring is completed and before energizing.

### **Electrical insulation resistance testing**

The insulation resistance shall be measured across earth and the whole system of conductors, or any section thereof, with all fuses in place and all switches closed and except in concentric wiring all lamps in position of both poles of the installation otherwise electrically connected together.

A direct current pressure of not less than twice the working pressure provided that it does not exceed 660 V for medium voltage circuits. Where the supply is divided from AC three phase systems, the neutral pole of which is connected to earth, either direct or through added

resistance, pressure shall be deemed to be that which is maintained between the phase conductor and the neutral.

The insulation resistance measured as above shall not be less than 50 mega ohms divided by the number of points on the circuit provided that the whole installation shall not be required to have an insulation resistance greater than one mega ohm.

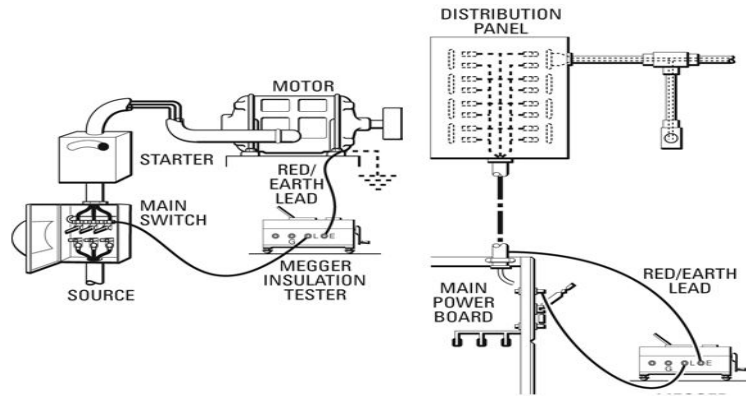

Figure 106:Insulation Megger testing of machine to panel board

The insulation resistance shall also be measured between all conductors connected to one phase conductor of the supply and all the conductors connected to the middle wire to the neutral or to the other phase conductors to the supply. Such a test shall be carried out after removing all metallic connections between the two poles of the installation and in these circumstances the insulation shall not be less than that specified above.

The insulation resistance between the case or frame work of housing and power appliances, and all live parts of each appliance shall not be less than that specified in the relevant British standard specification or where there is no such specification shall not be less than a mega ohm.

### **Electrical earth continuity path testing**

The earth continuity conductor metallic envelopes of cables, shall be tested for electric continuity and the electrical resistance of the same along with the earthing lead but excluding any added resistance or earth leakage circuit breaker measured from the connection with the earth electrode to any point in the earth continuity conductor in the completed installation shall not exceed one ohm.

### **Electrical testing of non-linked single pole switches**

In a two wire installation a test shall be made to verify that all non-linked single pole switches have been fitted in the same conductor throughout, and such conductor shall be labeled or

marked for connection, throughout, and such conductor shall be labeled or marked for connection to an outer or phase conductor or non-earthed conductor a test shall be made three or four wire installation a test shall be made to verify that every non linked single pole switch is fitted in a conductor to one of the outer or phase conductor of the supply. The entire electrical installation shall be subject to the final acceptance of the Supervising engineer as well as the local authorities.

### **Electrical earth resistivity testing**

Earth resistivity test shall be carried out in accordance with British Standard Code of Practice of Earthing. All tests shall be carried out in the presence of the Supervising Engineer.

### **Electrical performance testing**

The complete electrical installation and equipment shall be subject to the final performance test as intended for each and every equipment shall be tested as per the manufacturer's instructions.

### **Maintenance of tools**

When it comes to home improvement tools, regular maintenance tools are mandatory. Only a high-quality tool ensures excellent results and longevity.

As a passionate craftsman, you should know the essential tips about the maintenance of tools and equipment. Machine *maintenance tools* suffer a lot of wear and tear due to regular use. If you don't do proper maintenance, it may result in machine breakdown and damage. With the proper handling and maintenance, you may reduce any risks. That is why you should do a regular check-up of your machine tools.

### **Basic Tips about Maintenance Tools and Equipment**

#### **Clean the Tools Regularly.**

Whenever you use any tools for your projects, make sure to clean them immediately. The next day, you'll notice there is a layer of dirt that may lead to rust.

That's why you should clean the tools after use. You don't need to use chemicals every time, sometimes wiping is good enough.

#### **Lubricate the Tools.**

Machine tools include moving parts that require lubrication to work smoothly. Check the details daily, whether they are properly lubricated.

Please read the instruction in case of power tools as it requires an adequate level of oil

#### **Sharpen the Essential Parts.**

Some equipment is used for cutting and slicing, such as blade, drill bits, and lathe tools. You'll need to check whether it is sharp or not.



If these tools are not sharp enough, it may result in serious injuries.

### **Check the Function of the Tools.**

You should check the functions of the tools for any damage or fault. Scrutinize each part. If any faulty functioning is found, then immediately repair them.

### **Check Machines Tools, Alignments.**

Most of the time, the machine works with fault due to improper alignment. Improper alignment also affects the tools in a negative way.

So, you should check the arrangement every time you intend to use the tool.

To ensure proper alignment, you may want to perform a few test tasks. If it is working well, that means the machine is all set.

### **Store with Care.**

Proper storing also enhances the lifetime of any machine tools. Moisture and air is the reason for rust over the metal surface of the devices.

You will need to keep the tools in a place that is dry and clean.

If the tools are extensive, keep it in a tight closing garage or dry basement or insulated rooms.

Conversely, store the small tools in an air-tight box. Make sure to cover the device and inspect them regularly.

### **Care for Electrical Cords and Batteries.**

The cable wires in some tools are prone to damage. Power tools like circular saw or drill may cut the wires accidentally. That's why you should keep them protected. You may want to use purpose-built ramps or industrial-strength casing. If the tool is battery operated, inspect the battery from time to time. Don't let sit it for long. Also, recharge it if needed.

### **Require Decent care of Parts and Accessories.**

It truly is crucial to carry out regular maintenance checks. On each one of your accessories and components. A vitally significant part of perfect maintenance.

It is always to need to take specific most care of your tools accessories.

And parts have been managed and kept sensibly. You really don't desire to be more careless using almost any component of one's system application.

Good awareness plays a significant role. Use each one you sense to find prospective issues.

A strange noise, an odd scent or unordinary vibration may indicate a problem.

All items which may be easily cared for if discovered early.

Keeping a checklist and logging all of the upkeep completed will maximize the procedure.

### **Storage of tools**

The proper care and storage of tools and equipment are not only the concern of the management but of the workers who use the equipment.

### Importance of proper storage of tools and equipment

- i. It is an important factor for safety and health as well as good business.
- ii. Improves appearance of general-shop and construction areas.
- iii. Reduces overall tool cost through maintenance.
- iv. This also ensures that tools are in good repair at hand.
- v. Teaches workers principles of (tool) accountability.

### Points to consider in storing tools and equipment:

- i. Have a designated place for each kind of tools.
- ii. Label the storage cabinet or place correctly for immediate finding.
- iii. Store them near the point of use.
- iv. Wash and dry properly before storing.
- v. Store knives properly when not in use with sharp edge down.
- vi. Put frequently used items in conveniently accessible locations.
- vii. Gather and secure electrical cords to prevent entanglement or snagging.
- viii. Cutting boards should be stored vertically to avoid moisture collection.
- ix. Metal equipment can be stacked on one another after drying such as storage dishes and bowls.
- x. Make sure the areas where you are storing the equipment are clean, dry and not overcrowded.

### **Good housekeeping**

Effective housekeeping can help control or eliminate workplace hazards. Poor housekeeping practices frequently contribute to incidents. If the sight of paper, debris, clutter and spills is accepted as normal, then other more serious hazards may be taken for granted.

Housekeeping is not just cleanliness. It includes keeping work areas neat and orderly, maintaining halls and floors free of slip and trip hazards, and removing of waste materials (e.g., paper, cardboard) and other fire hazards from work areas. It also requires paying attention to important details such as the layout of the whole workplace, aisle marking, the adequacy of storage facilities, and maintenance. Good housekeeping is also a basic part of incident and fire prevention.

Effective housekeeping is an on-going operation: it is not a one-time or hit-and-miss clean-up done occasionally. Periodic "panic" clean-ups are costly and ineffective in reducing incidents.

### **Purpose of workplace housekeeping**

Poor housekeeping can be a cause of incidents, such as:

- ❖ Tripping over loose objects on floors, stairs and platforms

- ❖ Being hit by falling objects
- ❖ Slipping on greasy, wet or dirty surfaces
- ❖ Striking against projecting, poorly stacked items or misplaced material
- ❖ Cutting, puncturing, or tearing the skin of hands or other parts of the body on projecting nails, wire or steel strapping

To avoid these hazards, a workplace must "maintain" order throughout a workday. Although this effort requires a great deal of management and planning, the benefits are many.

### **Benefits of good housekeeping practices**

Effective housekeeping results in:

- ❖ Reduced handling to ease the flow of materials
- ❖ Fewer tripping and slipping incidents in clutter-free and spill-free work areas
- ❖ Decreased fire hazards
- ❖ Lower worker exposures to hazardous products (e.g. Dusts, vapours)
- ❖ Better control of tools and materials, including inventory and supplies
- ❖ More efficient equipment clean-up and maintenance
- ❖ Better hygienic conditions leading to improved health
- ❖ More effective use of space
- ❖ Reduced property damage by improving preventive maintenance
- ❖ Less janitorial work
- ❖ Improved morale
- ❖ Improved productivity (tools and materials will be easy to find)

### **Good housekeeping program**

A good housekeeping program plans and manages the orderly storage and movement of materials from point of entry to exit. It includes a material flow plan to ensure minimal handling. The plan also makes sure that work areas are not used as storage areas by having workers move materials to and from work areas as needed. Part of the plan could include investing in extra bins and more frequent disposal.

The costs of this investment could be offset by the elimination of repeated handling of the same material and more effective use of the workers' time. Often, ineffective or insufficient storage planning results in materials being handled many times and being stored in hazardous ways. Knowing the workplace layout and the movement of materials throughout it will help when planning work procedures.

Worker training is an essential part of any good housekeeping program. Workers need to know how to work safely with the products they use. They also need to know how to protect other

workers such as by posting signs (e.g., "Wet - Slippery Floor") and reporting any unusual conditions.

Housekeeping order is "maintained" not "achieved." Cleaning and organization must be done regularly, not just at the end of the shift. Integrating housekeeping into jobs can help ensure this is done. A good housekeeping program identifies and assigns responsibilities for the following:

- Clean up during the shift
- Day-to-day cleanup
- Waste disposal
- Removal of unused materials
- Inspection to ensure cleanup is complete

Do not forget out-of-the-way places such as shelves, basements, sheds, and boiler rooms that would otherwise be overlooked.

The final step to any housekeeping program is inspection. It is the only way to check for deficiencies in the program so that changes can be made. Examples of checklists include inspecting offices and manufacturing facilities.

### **Documentation and reporting**

Documentation is about documents, which communicate information. Those documents provide information for and about a certain object, process or topic. Documentation can be published in digital (CD, DVD, disc, memory stick, download, as a web site,) or in analogue (book, paper, poster, photo.) form. Furthermore, digital documentation can be presented in an interactive manner, which increases ease of use. Examples for interactive features are, among others, cross references, search, tip-of-the-day features, contextual information, wizards or knowledge-based help systems.

Another important characteristic of documentation is the level of detail. There may exist several documents describing the same aspect, but are intended for a different audience (with varying domain knowledge) and thus serve a different purpose. Software system underlies continuous changes throughout their whole life cycle. As a consequence, also the amount of information grows continually. For international software systems, the documentation has to be available in multiple languages. All these aspects contribute to the problems of documentation: Keeping up with changes during the development, propagating changes in requirements documents, design documents to the development and keeping documents on the desired level of quality

### **Learning Activities**

KENM is a fashion industry in Taita Taveta County. An electrical shock occurs in one of its production lines. As the industry lead installation technician lead your team in carrying out the following tests to identify the root cause of the problem

- ❖ Continuity test
- ❖ Insulation resistance tester
- ❖ Earth loop impedance
- ❖ Polarity test

### Self-Assessment

1. What Happens if a Fluorescent Bulb Breaks?
2. Do I Need an Electrician to Install Under Cabinet Lights?
3. How is continuity test performed?
4. How is measurement of earth resistance carried out using earth tester?
5. Show how does a Ring circuit work?

### Tools, Equipment, Supplies and Materials

- ❖ Multimeter/AVO meter
- ❖ Wattmeter
- ❖ Insulation resistance tester
- ❖ Loop impedance tester
- ❖ Earth resistance tester
- ❖ Clamp meter
- ❖ Power quality analyser
- ❖ Infrared camera
- ❖ Phase sequence meter
- ❖ Frequency meter
- ❖ Synchroscope
- ❖ Tachometer
- ❖ Tacho generator
- ❖ Laser meter
- ❖ Lux meter

easyvet.com

### References

- i. <https://homeguides.sfgate.com/identify-antique-lighting-fixtures-20282.html>
- ii. <https://www.wrightlighting.com/blog/2014/10/different-types-of-lighting-fixtures/>
- iii. <https://www.pickamachine.com/maintenance-tools-and-equipment/>
- iv. <https://www.assemblymag.com/articles/83099-wire-termination-uses-and-methods>

- v. [https://www.facebook.com/permalink.php?id=478424296051998&story\\_fbid=479078152653279](https://www.facebook.com/permalink.php?id=478424296051998&story_fbid=479078152653279)
- vi. <https://www.ccohs.ca/oshanswers/hsprograms/house.html>
- vii. Mario Gastegger and Simon Zünd, Maintenance of technical and user documentation, 2015

### **Answers to self-assessment test**

1. Older fluorescent bulbs have mercury gas contained within them. If the bulb breaks, leave the area and wait for the gas to dissipate. The newer CFL fluorescent bulbs have very little mercury gas and are not harmful. Your local home improvement center will likely have a free collection box for you to drop off old or used bulbs.
2. Under cabinet lights can be installed by the homeowner if you follow the instructions and take all of the appropriate precautions during the installation process. If you are not comfortable working with electricity, then absolutely hire a professional.
3. A continuity test is performed by placing a small voltage (wired in series with an LED or noise-producing component such as a piezoelectric speaker) across the chosen path. If electron flow is inhibited by broken conductors, damaged components, or excessive resistance, the circuit is "open".
4. Earth resistivity is usually measured using the Wenner method, which involves the use of four temporary earth spikes. The spikes do not need to be moved as part of the testing procedure however – their location and spacing is determined by the depth at which it is required to determine the earth resistivity.
5. The power sockets in a house are connected by means of a ring circuit. In a ring circuit the live, neutral and earth wires form a loop of cable going from the consumer unit to all of the sockets in turn and then back to the consumer unit. The live wire carries current to the house/appliance at a high voltage.

### **3.3.Perform basic repair and maintenance of installation and appliances**

#### **Introduction to the learning outcome**

An appliance installation and repair program gives students the skills necessary to service, repair and install any commercial or consumer electric, gas or microwave appliance.

#### **Performance Standard**

1. Repair and maintenance
2. Identification, selection and application of maintenance tools and equipment.
3. Perform repair on the appliance in line with the manufacture's manual.
4. Maintain the installation and appliances in line with the set standards

5. Manufacture's manual use in fault identification and appliances repair process
6. Standards in appliances and installation maintenance and repair process

## **Information Sheet**

### **Meaning of repair and maintenance**

Maintenance and Repair means activities relating to the maintenance and repair of electrical installations in accordance with and to the standard from time to time prescribed by by-law policy.

The maintenance and repairing of the electrical appliances are crucial for avoiding any disturbance or obstacle during work routine and also to prevent oneself and assets from any catastrophe.

Maintenance does not mean to wait for the time when the equipment or appliance goes out of functioning and display fault in its performance. The electronic equipment at home or at workplace demands maintenance by systematic and proper use and so it is a task to be performed on a regular basis. Improper use of appliances can disturb the functioning of the appliances.

### **Purpose and reasons of repair and maintenance**

Electrical components are some of the most intricate and complex systems in existence. Proper training is required to repair, troubleshoot and maintain systems and equipment that supplies electricity to industrial and commercial buildings. While electrical maintenance can be done by the owner or manager of the building, it's better if it's handled by someone who has completed electrical maintenance training and is suitably qualified to do the job.

Electrical issues are known to kill, injure, and cause property destruction if not maintained properly. The necessity for periodic inspection is noted in various regulations that deal with safety at work and home. One of the best things to do is to hire an expert to conduct a visual inspection periodically for all electrical installations at your home or office.

### **Reasons to conduct periodic electrical maintenance:**

- i. Test the reliability and proper functioning of installed electrical equipment.
- ii. Protective measures for safety.
- iii. Taking care of defects that may be dangerous.
- iv. Protection against damage to property by fire.
- v. It may be a requirement for securing compensation from the insurance company in case of property damage due to fire.

### **Fault identification**

In an electric power system, a fault or fault current is any abnormal electric current. For example, a short circuit is a fault in which current bypasses the normal load. An open-circuit

fault occurs if a circuit is interrupted by some failure. In three-phase systems, a fault may involve one or more phases and ground, or may occur only between phases. In a "ground fault" or "earth fault", current flows into the earth.

### **Finding Electrical Faults**

At times, **finding electrical faults** is hard. Electrical faults cause some faults or defects and therefore necessitate electrical troubleshooting. When tracing and rectifying the faults, you have to keep in mind that there are the electrical problems can arise due to one of the following three causes.

#### **Open circuit**

An open circuit occurs when a connection breaks. To test such a problem, you will have to use the continuity test.

#### **Short circuit**

Any closed connection is known as a short circuit. Such a connection causes flow of excess current in the circuit and damages the electrical components. A short circuit problem mostly arises due to damaged/weak insulation that you can detect with the insulation test. To troubleshoot a short circuit, check channel resistance, the potential difference between at least two points and the flow of current. Check the input voltage and check the total voltage at various test points on the PCB. Ensure that every protection device is operating in properly.

Typically, an electrical circuit features two main components: control circuit and the power circuit. Therefore, you will have to start by ensuring that:

- ❖ The input voltage exists
- ❖ The protection devices are functioning properly
- ❖ Channel resistance is normal
- ❖ Every component is not physically damaged due to excess heat

For the control circuit, ensure that:

- ❖ The input voltage to the control circuit is right,
- ❖ The switches, relays and timers are healthy,
- ❖ The cable has continuity,
- ❖ The contact switches are functioning logically and
- ❖ The timing of your switching circuit is right

### **The continuity tests**



You can check the continuity of your circuit in two ways: the dead continuity and the power on continuity. The dead continuity testing requires you to switch off the power to reduce the risk of a shock. When conducting an insulation test, you will have to switch off the power too.

To check for the circuit continuity when the power is off, you will millimeter the multi-meter knob on beep sound. The beep will confirm that the electrical path is complete. If the path is broken, you should not expect a beep.

### **IEE regulations on fault identification, maintenance and repair process**

The study of a proposed electrical installation requires an adequate understanding of all governing rules and regulations.

Low-voltage installations are governed by a number of regulatory and advisory texts, which may be classified as follows:

- ❖ Statutory regulations (decrees, factory acts, etc.)
- ❖ Codes of practice, regulations issued by professional institutions, job specifications
- ❖ National and international standards for installations
- ❖ National and international standards for products

### **Meaning of fault identification**

Electrical powers system is growing in size and complexity in all sectors such as generation, transmission, distribution and load systems. Types of faults like short circuit condition in power system network results in severe economic losses and reduces the reliability of the electrical system.

Electrical fault is an abnormal condition, caused by equipment failures such as transformers and rotating machines, human errors and environmental conditions. These faults cause interruption to electric flows, equipment damages and even cause death of humans, birds and animals.

### **Manufacture's manual use in fault identification and appliances repair process**

Your equipment owner's manual may not sound like interesting reading material, but taking some time to review this information can potentially save you time and money. These manuals, which are commonly stored in glove compartments and are often available on manufacturers' websites, contain important information and instructions regarding your equipment's maintenance and service needs. Following these maintenance and service guidelines will help to ensure the longevity and reliability of your equipment

### **Here are the top 5 reasons you should read your owner's manual:**

- ❖ Maintenance Schedule

- ❖ Maintaining your equipment is important. Educate yourself on what services your equipment needs and when they are recommended. If your electrician recommends that your equipment be serviced, ask why the service is needed and if it is recommended by the manufacturer. If you are still unsure why a service is required or how it will benefit your equipment or machine, don't feel pressured to agree to the service until you can do some research. Additionally, be sure to keep good records of all services done on your equipment. Many manuals include helpful logs to record your service history and repair information.

### **Fluid Requirements**

In addition to knowing how often to service your equipment, it's also a good idea to know what types of other services your equipment requires and when they should be done.

### **Setup Helpful Reminders**

It can be difficult to remember when your equipment's parts need to be changed.

### **Warranty Information**

Before agreeing to any repairs on your equipment or machine, consult your owner's manual for any parts or repairs that may be covered under your equipment's or machine's warranty. Also, pay close attention to any products that are not recommended by the manufacturer and any services that may void your warranty if performed.

### **Standards in appliances and installation maintenance and repair process**

This information sheet contains specific advice about some of the ways of avoiding injury during the servicing and repair of domestic appliances such as washing machines, dryers, refrigerators/freezers, cooking equipment etc., normally operating from a 230-volt supply.

### **How can injuries happen during testing?**

The most significant danger to people carrying out electrical testing work is that they might suffer an electric shock. Any simultaneous contact of a part of the body with a conductor that is live at a dangerous voltage, e.g., one that is connected to the mains supply while another part of the body is connected to an earth, will result in an electric shock. There is also a risk of burn injuries resulting from arcing when conductors are accidentally short-circuited.

An electric shock can lead to serious injury, sometimes fatal. Injuries can also occur when a person reacts to an electric shock, for example by falling or touching another hazard. Factors which are likely to increase the risk of receiving an electric shock include the following:

- a) The majority of domestic appliances have large areas of earthed metal that may be easily touched. Touching exposed live conductors connected to the mains supply at the same time as touching the earthed metalwork will result in an electric shock;

- b) Some appliances could also be using water in their operation, such as washing machines or dishwashers. This may lead to an increased risk of shock because water can conduct electricity and reduces the resistance of the skin;
- c) When working on microwave ovens there may be a risk of severe electric shock from the internally generated high voltage (approximately 4kV);
- d) Work may be carried out in the customer's home, so people other than those doing the work (including children) may also be at risk;
- e) Additional risks may be present at the customer's premises if their electrical installation is not electrically sound, e.g., earthing, insulation resistance, polarity.

### Learning Activities

During the course working in the production factory, the lighting in the office of the production manager goes off while lights remain in the other rooms. Carry out the following steps to locate the fault.

- ❖ Collect the Evidence
- ❖ Analyze the Evidence
- ❖ Locate the Fault
- ❖ Determination and Removal of the Cause
- ❖ Rectification of the Fault
- ❖ Check the System

easyvet.com

### Self-Assessment

1. What are the components of lighting systems?
2. What are the goals of lighting maintenance?
3. What are common preventative maintenance schedules and checklists for lighting?
4. Mention what are the challenges that maintenance and repair work usually face?
5. What is the potential risk that repair and maintenance work usually face?

### Tools, Equipment, Supplies and Materials

- ❖ Multimeter/AVO meter
- ❖ Wattmeter
- ❖ Insulation resistance tester
- ❖ Loop impedance tester
- ❖ Earth resistance tester
- ❖ Clamp meter
- ❖ Power quality analyser

- ❖ Infrared camera
- ❖ Phase sequence meter
- ❖ Frequency meter
- ❖ Synchroscope
- ❖ Tachometer
- ❖ Tacho generator
- ❖ Laser meter
- ❖ Lux meter

## References

- i. <https://www.onewayelectrical.co.uk/electrical-maintenance-necessary/>
- ii. <https://www.tcd.ie/eleceng/safetystatement/Electrical/eis35.pdf>

## Answers to self-assessment test

1. Among the items you'll need to factor into your PM scheduling are the following:

- ❖ Lamps or bulbs, including fluorescent, incandescent, and LEDs
- ❖ Ballasts, which control power and brightness
- ❖ Housing, used to protect and shield the lamp
- ❖ Lighting control, such as switches, dimmers, occupancy sensors, and timers

Each of these will need cleaning, check-ups, or replacement every so often in order to keep working optimally.

2. Typically, most lighting systems are designed to provide more lighting than is actually necessary. The reason for this is because lamps lose brightness over time.

- ❖ A solid preventive maintenance plan can slow light loss, meaning there's less necessity to overdesign the system. That translates into savings on initial installation as well as lower energy costs over time. Given how about 20% of money spent on electricity in the U.S. goes toward lighting, those savings can be significant.

In addition to reducing the costs of lighting overdesign, preventive lighting maintenance also aims to improve the following:

- ❖ Energy efficiency overall
- ❖ Addressing design issues
- ❖ Safety and security
- ❖ Aesthetic appeal

3. A common checklist used for lighting preventive maintenance is the one the U.S. Department of Energy outlines (provided below). That said, the items on your checklist will depend on the following:

- ❖ What components are you responsible for?
- ❖ Are there specific goals you are trying to achieve?
- ❖ What are your capabilities in terms of tools, equipment, procedures?

4. The challenges are:

- ❖ Unusual working condition like bad weather or low temperature
- ❖ May have to work in an unusual shift
- ❖ May have to work in a messy area
- ❖ May sometimes be physically distressing and exhausting
- ❖ May have to work in dangerous places like working at height or working with electrical appliances and wires

5. The potential risk that repairs and maintenance worker faces are

- ❖ Faulty electrical: Risk of electrocuted always remains with repair and maintenance workers, if not equipped with electric-proof tools and attires. They are prone to burns, shocks, etc.
- ❖ Lifting equipment: Workers usually have to deal with heavy metal objects and lifting equipment is not inspected or maintained then they are at risk of a fatal accident
- ❖ Maintenance of working and walking surfaces: Slippery working surfaces, sharp tools and nails scattered on working surface, slip and trip, uneven and potholed are some potential hazards that may cause an accident
- ❖ Dust: Its potential risk for the workers specially working in woodworking or iron industries.